



TM

# Timberkits Demon Dentist



(UK) Symbols in these instructions. (FR) Symboles des instructions. (ESP) Símbolos en estas instrucciones. (IT) Simboli in queste istruzioni. (Ger) Symbole in dieser anleitung



(UK) Waiting time.  
(FR) Temps d'attente.  
(ESP) Tiempo de espera.  
(IT) Tempo d'attesa.  
(DE) Wartezeit.



(UK) Wax surface to lubricate.  
(FR) Appliquer la cire sur cette surface.  
(ESP) Aplica la cera sobre esta superficie.  
(IT) Applicare la cera su questa superficie  
(DE) Wax Oberfläche zu schmieren.



(UK) Glue.  
(FR) Coller.  
(ESP) Pegar.  
(IT) Incollare.  
(DE) Leimen



(UK) Don't glue.  
(FR) Ne pas coller.  
(ESP) No pegar.  
(IT) Non incollare.  
(DE) Nicht leimen.



(UK) Glue guard. Prevents glue getting between moving parts during build. Remove after 2 minutes.  
(FR) Piece de protection contre la colle. pendant l'assemblage, eviter tout dépôt de colle sur les pieces en mouvement. Enlever apres 2 minutes.  
(ESP) Parte de protection de el pegamento. durante la fase de esambalje, evitar que el pegamento se ponga sobre partes que se mueven. Quitar despues de dos minutos .  
(IT) Pezzo di protezione della colla. Durante l'assemblaggio evitare che la colla vada su parti non statiche . Imuovere dopo due minuti.  
(DE) Karton. Verhindert das eindringen von leim zwischen die bewegliche teile während der montage. Zwischen die beweglichen Teile.

#### Helpful hints/conseils utiles/consejos utiles/suggerimentutili/nützliche tipps

(UK) Check all parts present in trays  
(FR) Vérifier que toutes les pièces soient présentes dans les bacs  
(ESP) Controlar que hay todas la partes en la caja  
(IT) Controllare tutte le parti presenti nel kit  
(DE) Bitte prüfen sie, ob alle benötigten teile vorhanden sind

(UK) Read all instructions and look at all diagrams  
(FR) Lire toutes les instructions et regarder toutes les figures  
(ESP) Leer las intrucciones y guardar a los diagramas  
(IT) Leggere tutte le istruzioni e guardare i diagrammi  
(DE) Lesen sie alle anweisungen und betrachten sie die schaubilder

(UK) Check assembly before gluing  
(FR) Vérifier le montage avant collage  
(ESP) Controlar el montaje antes de empezar a pegar  
(IT) Controllare l'assemblaggio prima di incollare  
(DE) Montage prüfen vor dem einklebern

(UK) Some parts may need sanding  
(FR) Certaines pièces nécessiteront d'être poncées.  
(ESP) Algunas parte necesitan de ser suavizadas  
(IT) Alcune parti potrebbero aver bisogno di levigatura  
(DE) Möglicherweise müssen manche teile geschliffen werden

Colouring tips/conseils concernant l'application de peinture/ consejos para Pintar/ suggerimenti per colorare/ lackiertipps

(UK) Do not apply paint to parts which move against one another. It is easier to paint some parts before assembling  
(FR) Ne pas appliquer de peinture sur les parties qui se déplacent l'une contre l'autre. Il est conseillé de peindre avant assemblage  
(ESP) No aplique la pintura sobre las partes que se tocan. Resulta mas facil pintar las partes antes de montar.  
(IT) Non applicare la pittura su quelle parti dove ce attrito con un'altra parte. è piu semplice pitturare alcune parti prima della fase di assemblaggio.  
(DE) Teile, die aneinander reiben, sollten nicht lackiert werden. Fertig lackierte teile sind off leichter zu montieren

#### New Symbols in our Instructions



Visit our website to view instructional videos where you see this symbol.

[www.timberkits.com](http://www.timberkits.com)



Pay special attention to this section.





**NEED ADVICE?**



**Luise Willis - Model Expert**

There's a Timberkit human  
here to help!

Or visit our website for tips, advice and instructional videos.  
All these can be found in Resources/Advice Videos on our website.

[www.timberkits.com](http://www.timberkits.com)

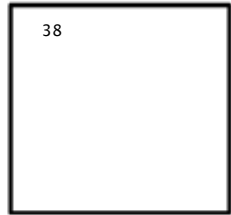
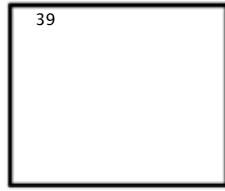
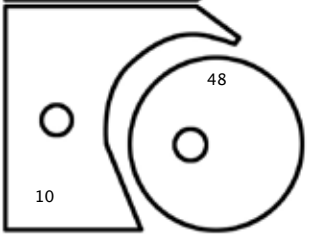
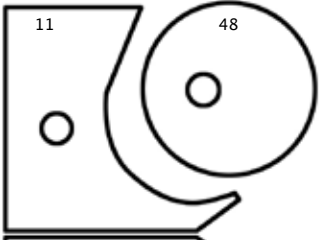
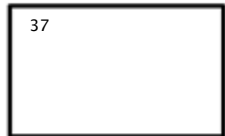
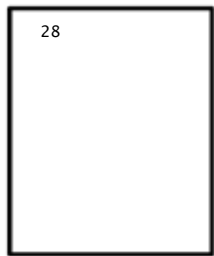
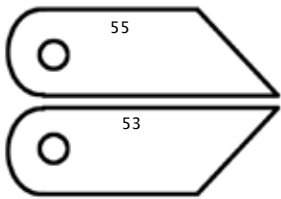
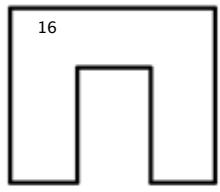
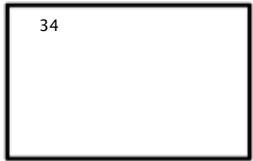
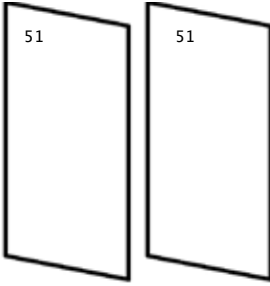

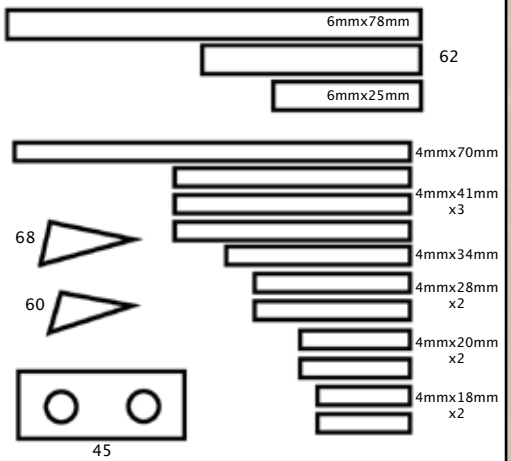
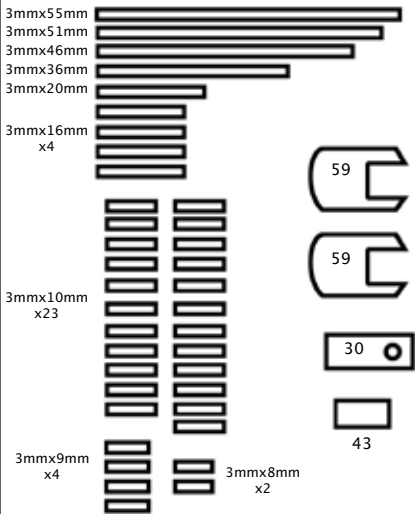
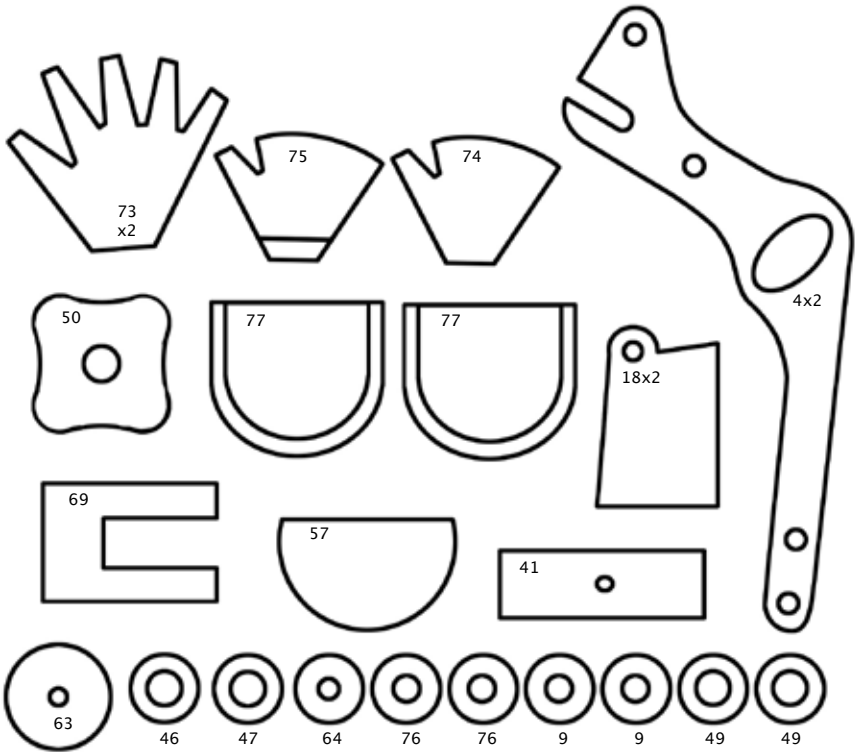

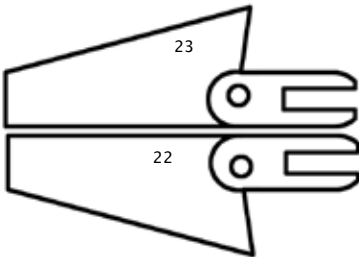
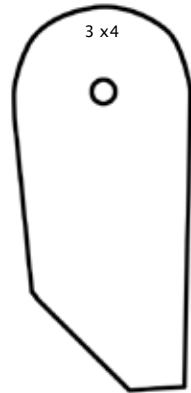
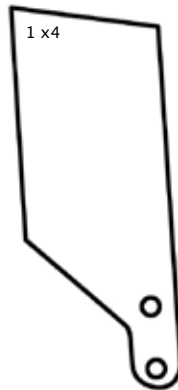
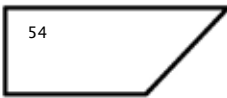
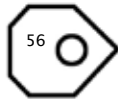
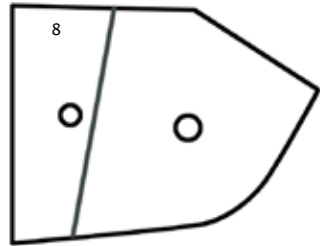
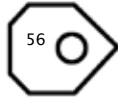
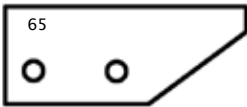
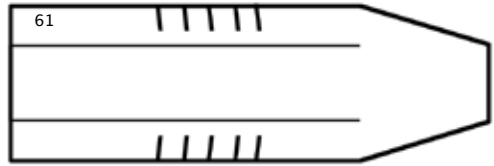
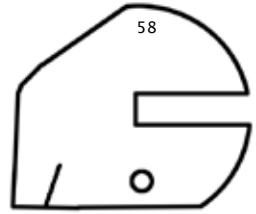
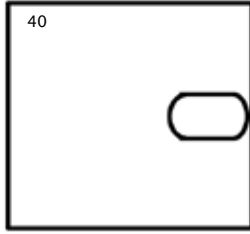
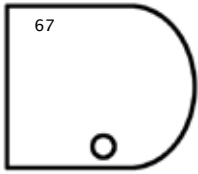

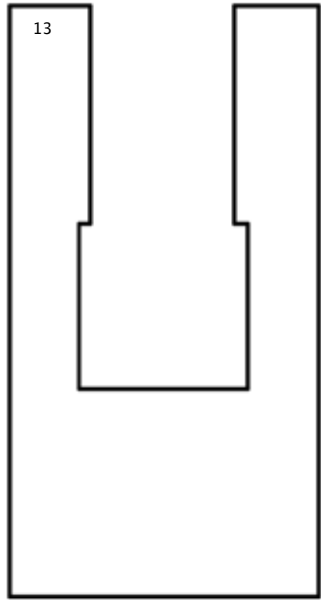
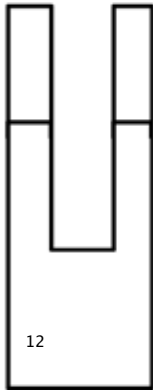
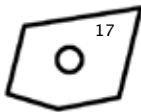
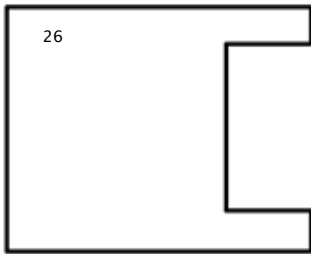
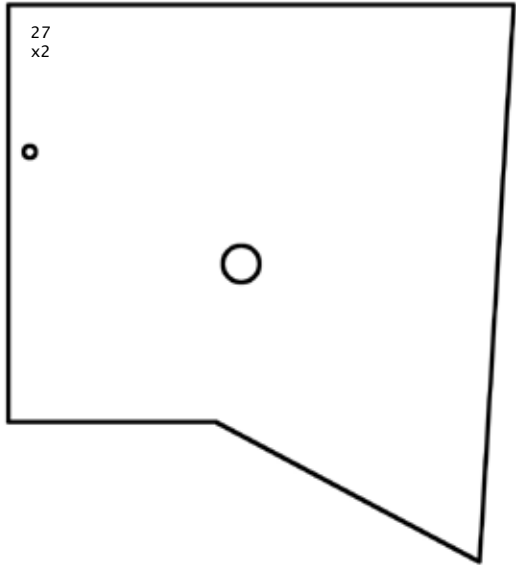
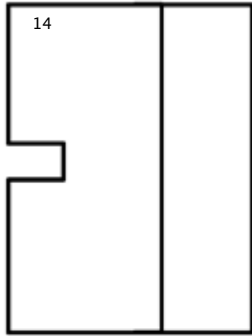

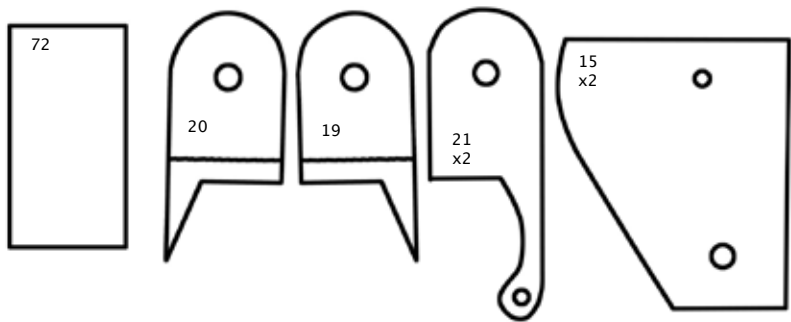
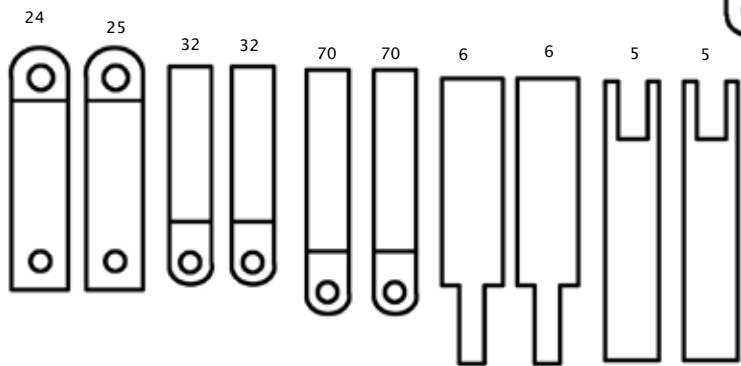
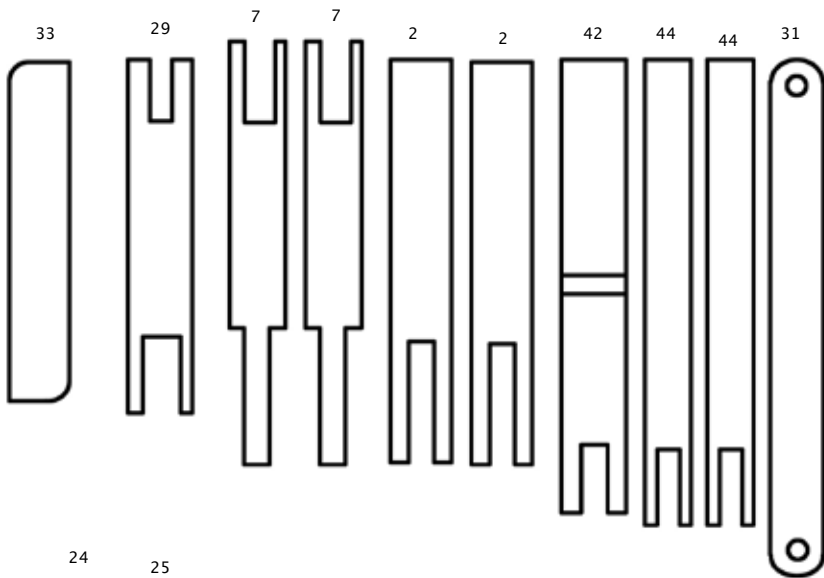



1

# Patient Right Leg

3mmx16mm

1a



3mmx16mm

1b



1c

2

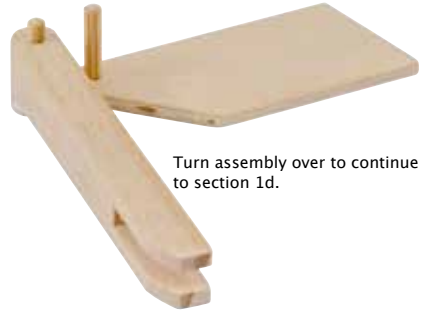
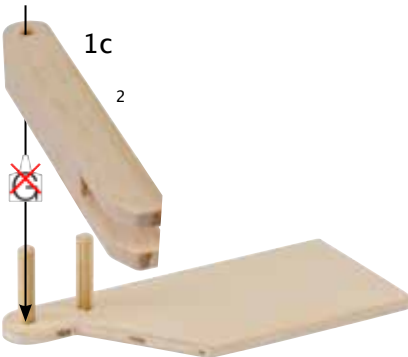

Turn assembly over to continue to section 1d.

1d

3

Ensure edge of part 3 lines up with part 2

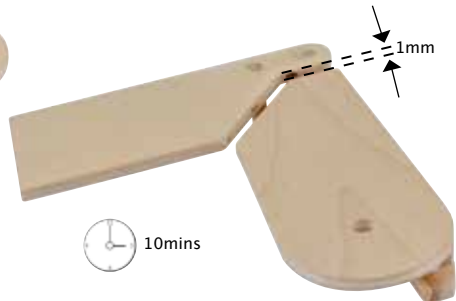
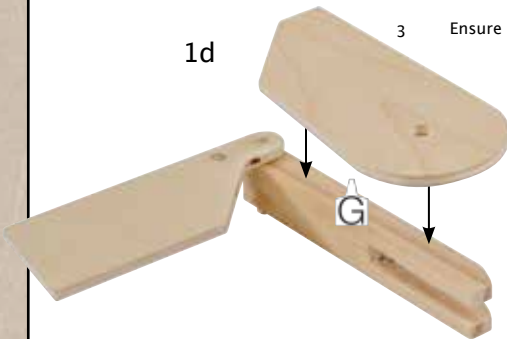

# 2

2a

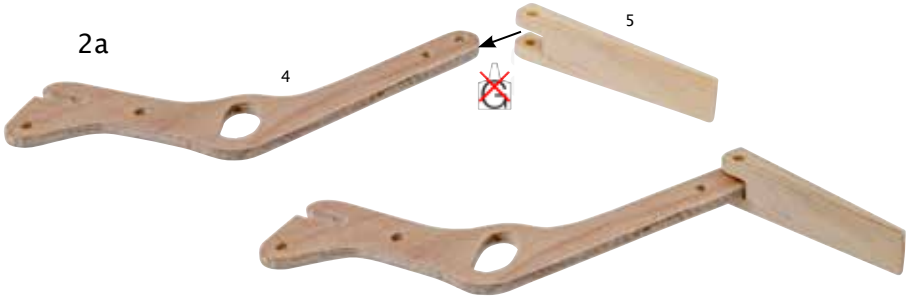

2b

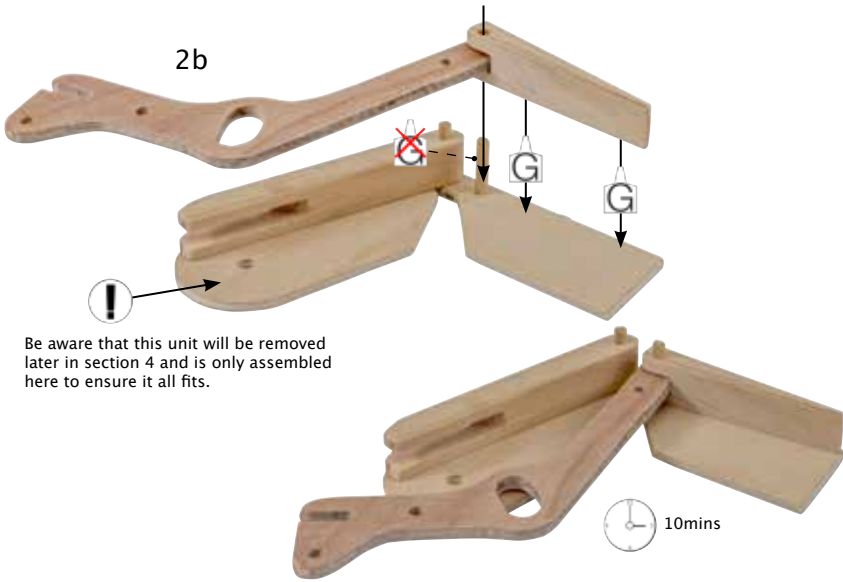

Be aware that this unit will be removed later in section 4 and is only assembled here to ensure it all fits.

2c

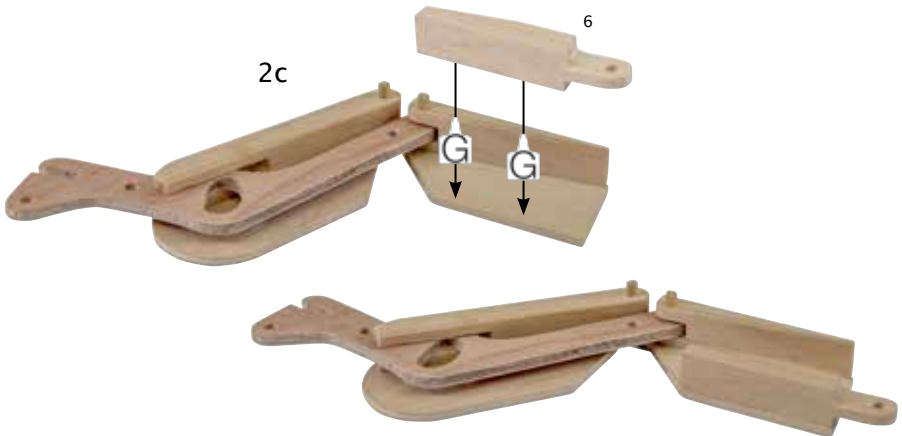

2d

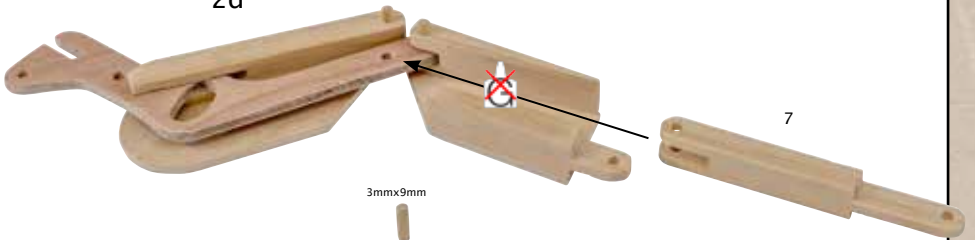

2e

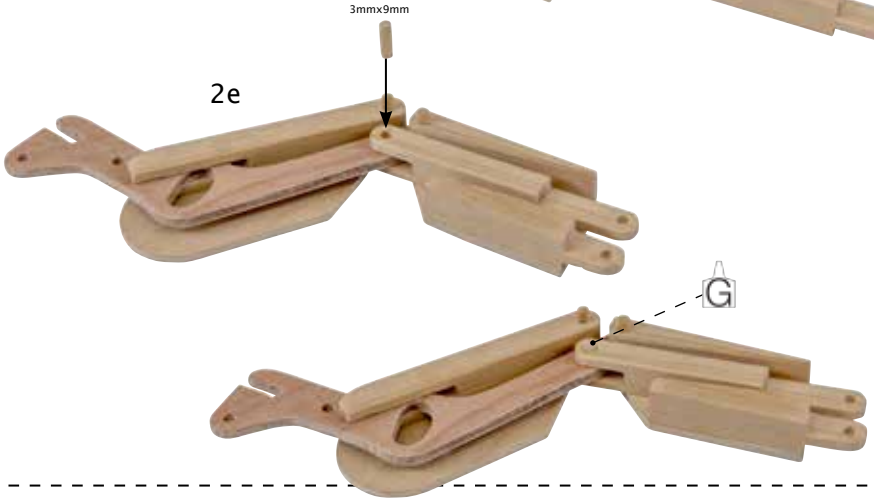

3

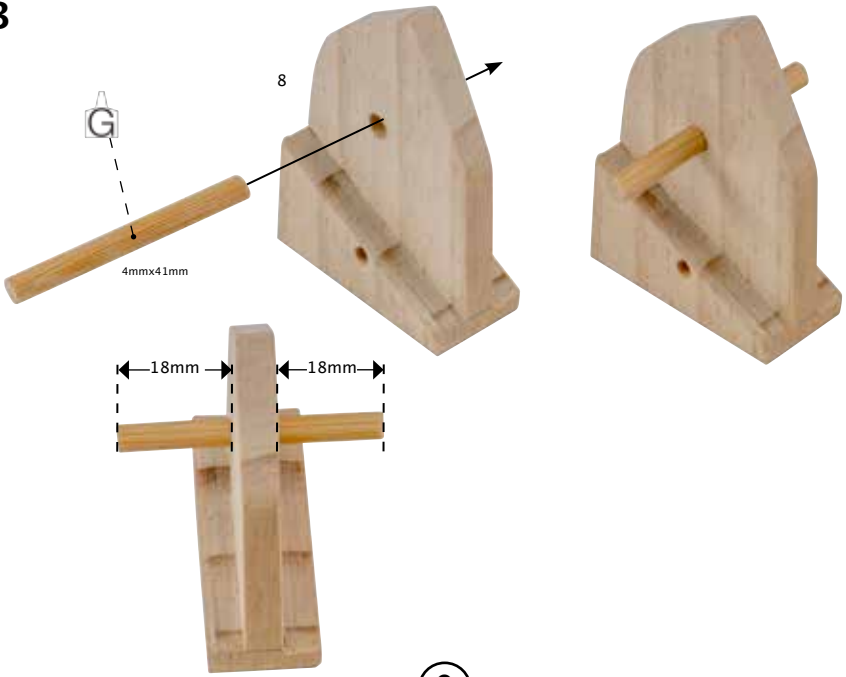

4



Unit 2/3 has now been removed from assembly as mentioned in section 2

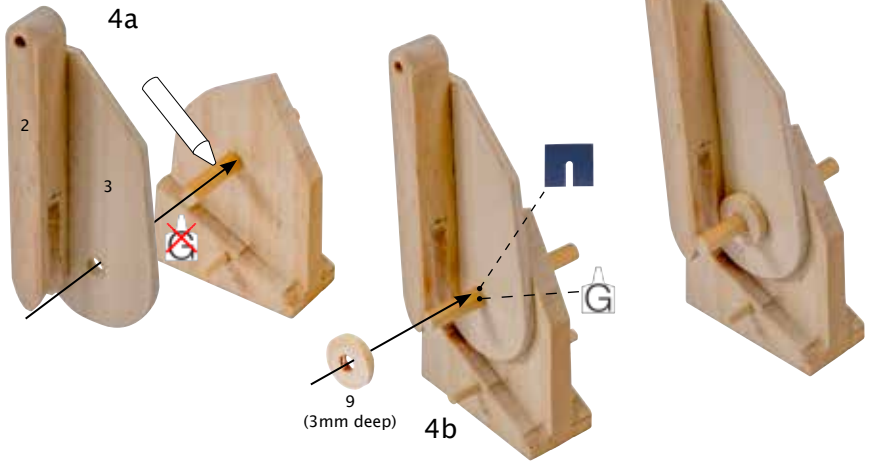

5

Patient Left Leg

5a

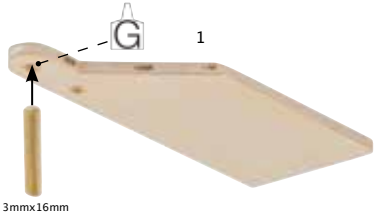

5b

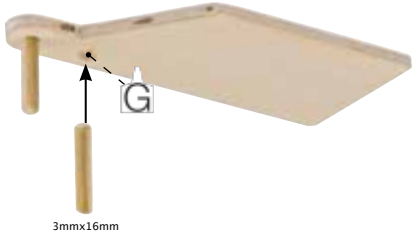

5c

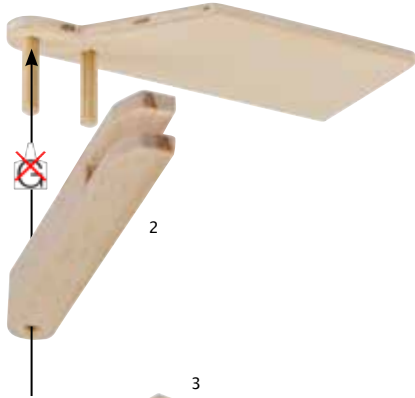

5d

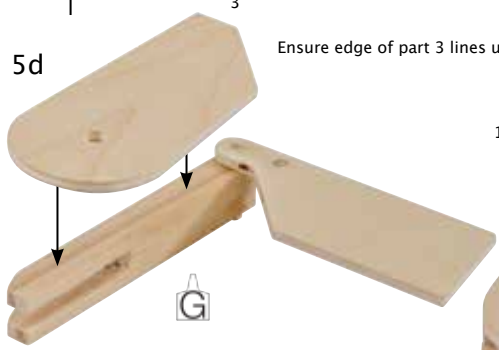

Ensure edge of part 3 lines up with part 2

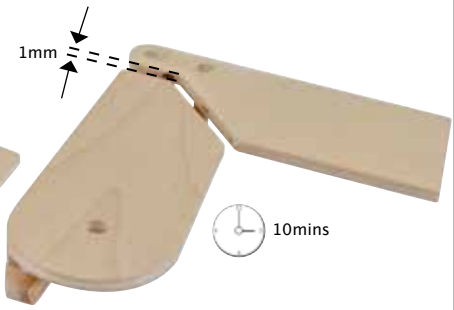

# 6

6a

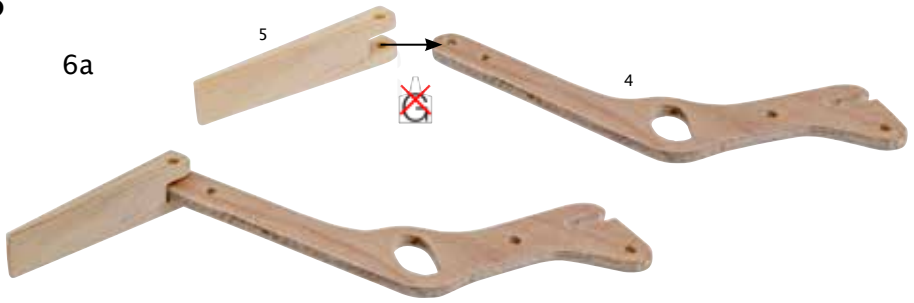

6b



 10mins

6c

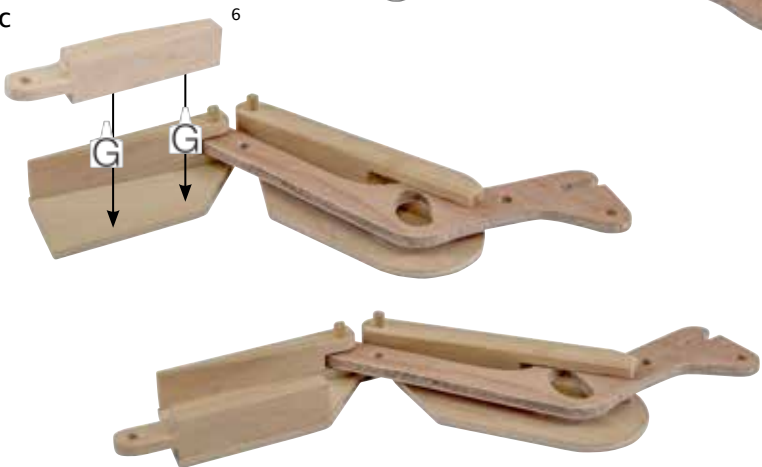

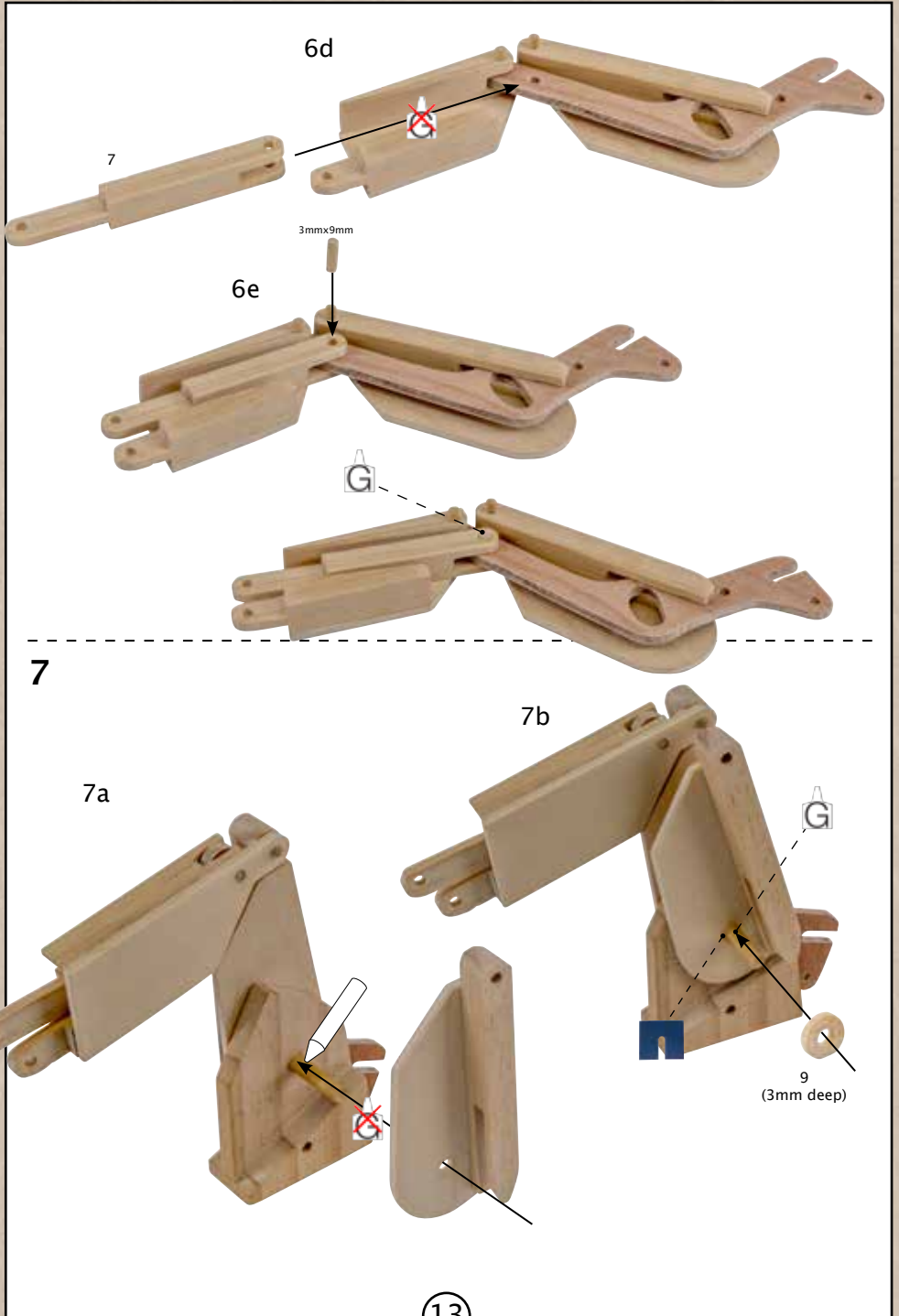

7c

Place 3mm x 16mm peg in  
left leg assembly into top  
hole in part #2.

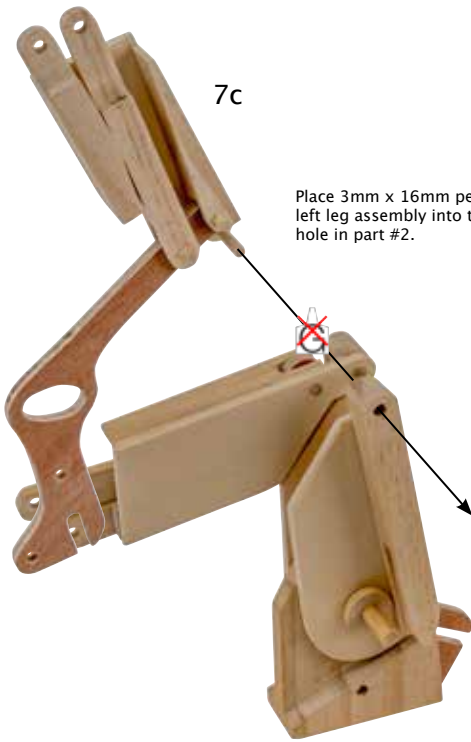

7d

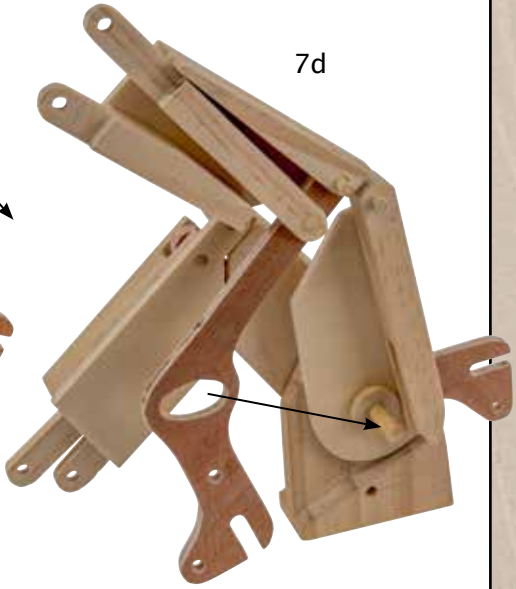

Gently lift part #4 so that  
the slot engages on the  
4mm x 41mm peg as  
shown.





8

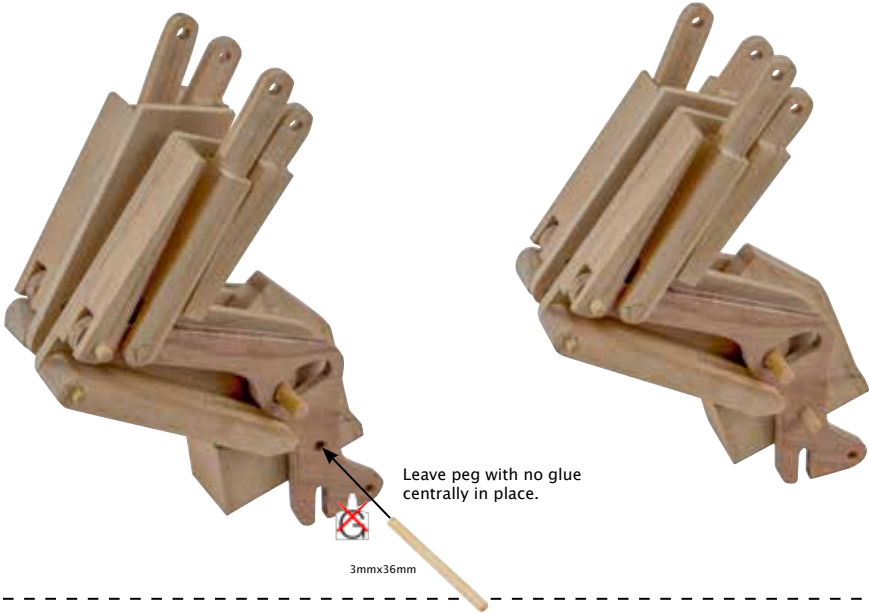

9

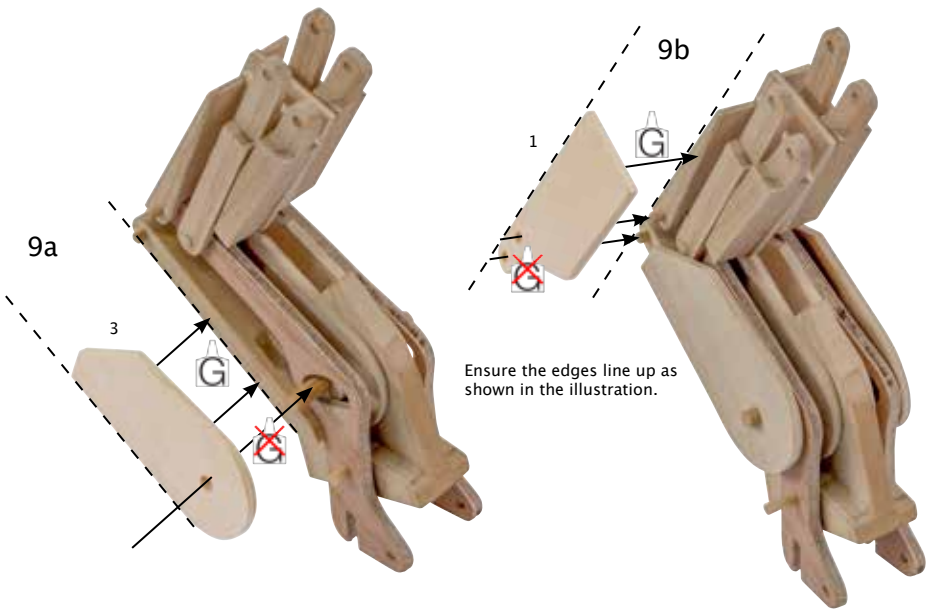

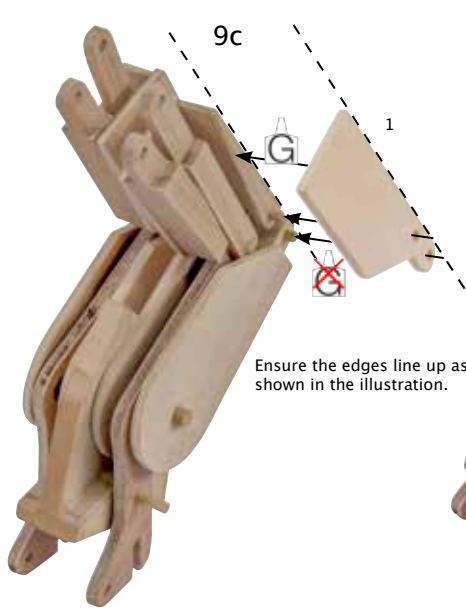

Ensure the edges line up as shown in the illustration.

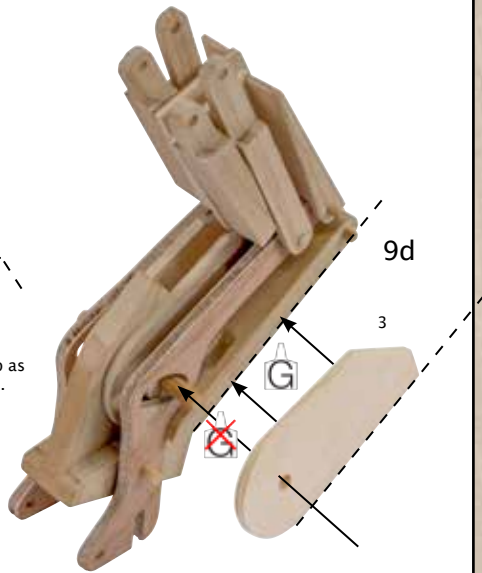

10

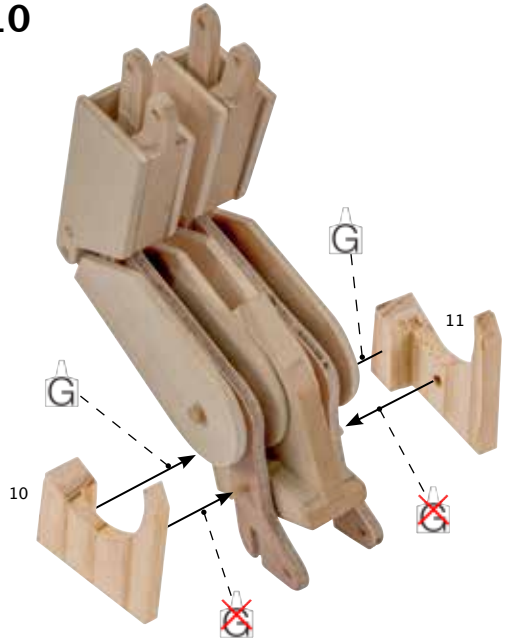

Lay leg assembly down on the long edges (marked with \*) of parts #10 and #11 to help line up parts #8 #10 and #11 whilst the glue dries.

11

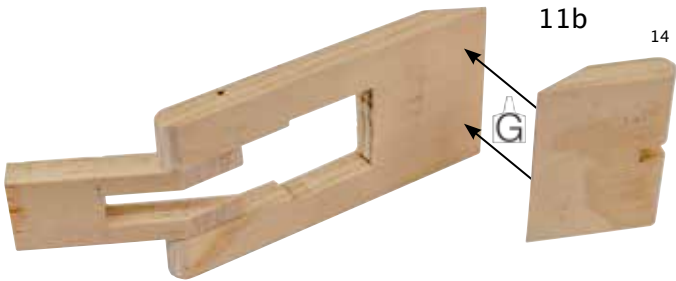
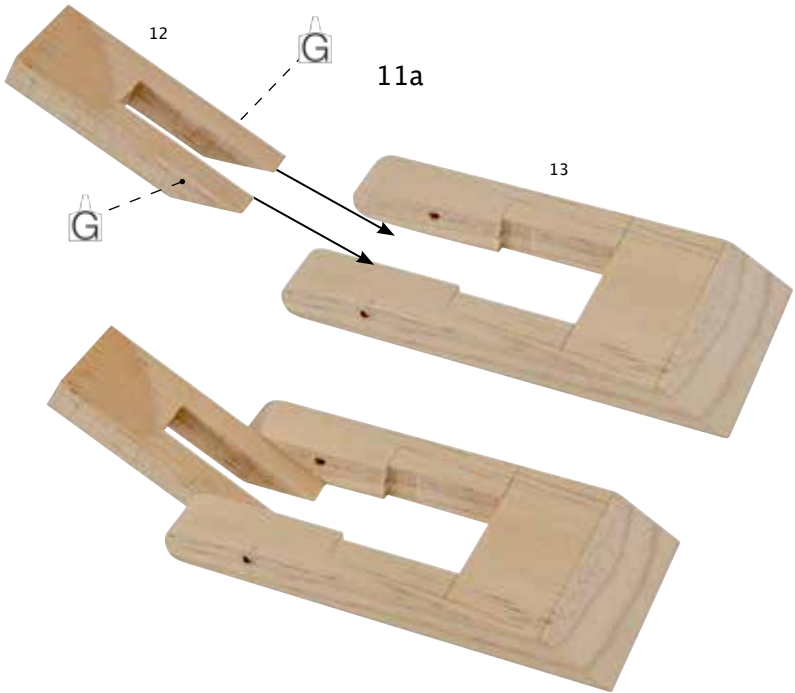

Glue in line with the angle on part #13.

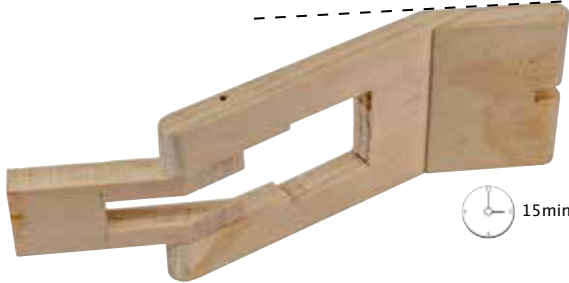

17

12

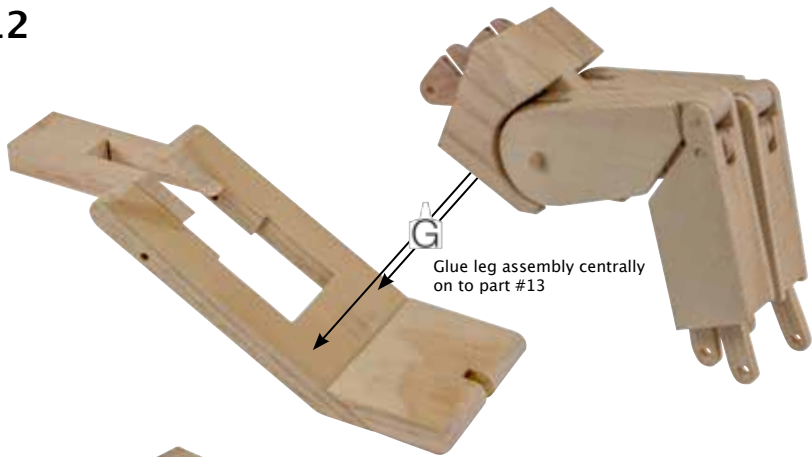

Glue leg assembly centrally on to part #13

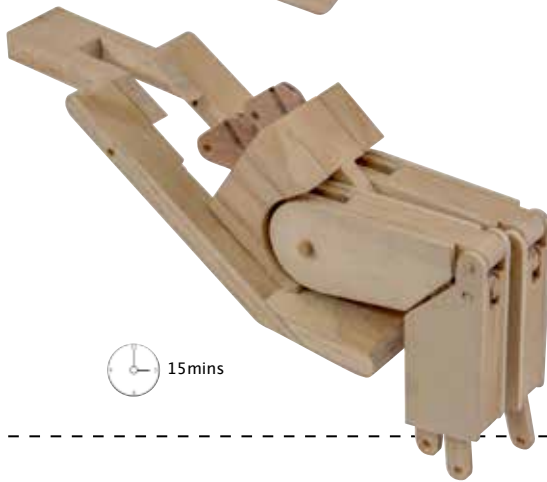

13

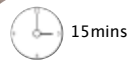
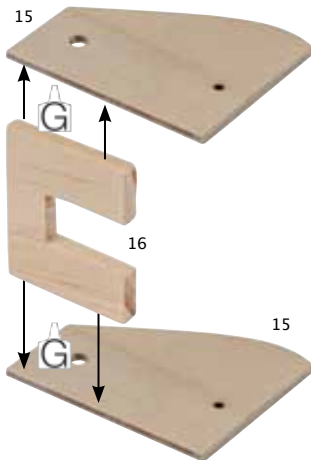

14

Side view

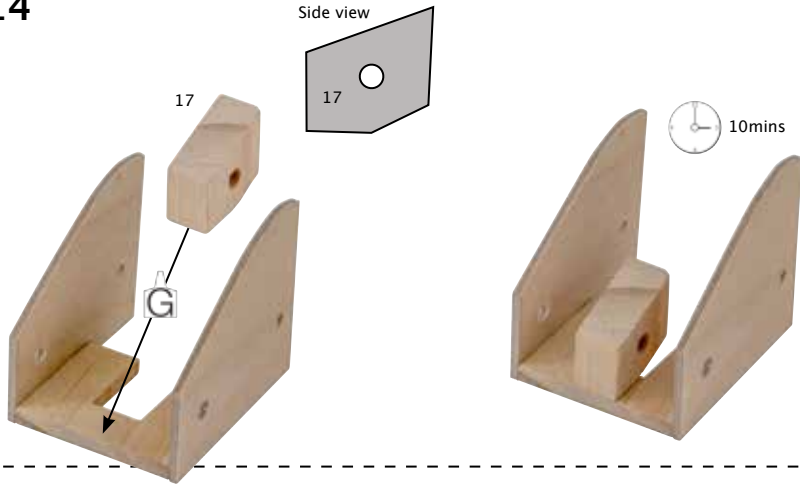

15

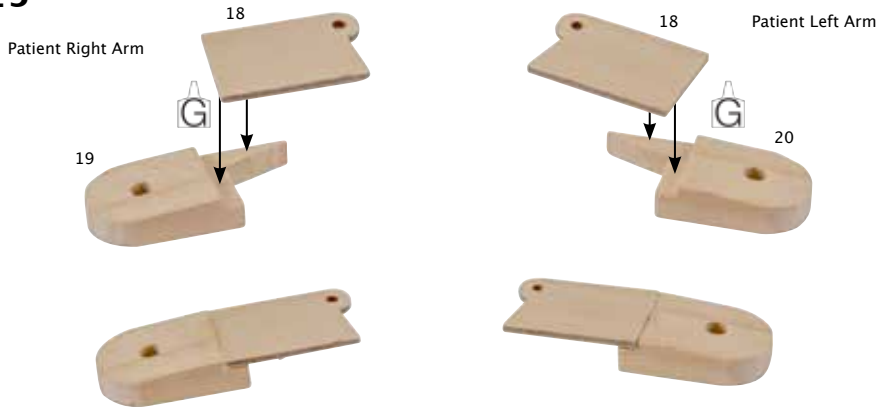

16

Push 4mm x 28mm pegs through the hole in parts 21 by about 3mm with no glue.

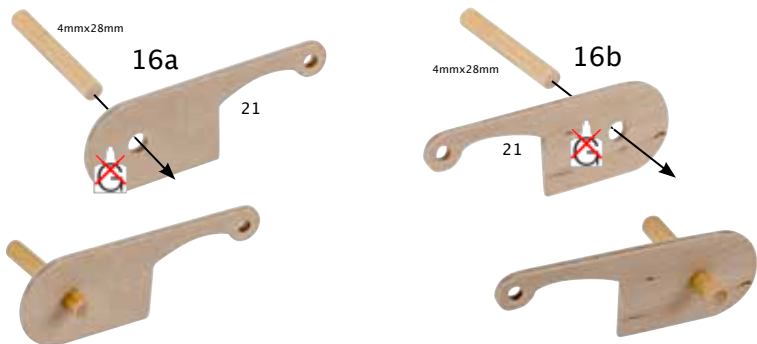

Patient Right Arm

16c

Push the 4mmx28mm peg into the hole in part #19 until it is flush with the outer edge.

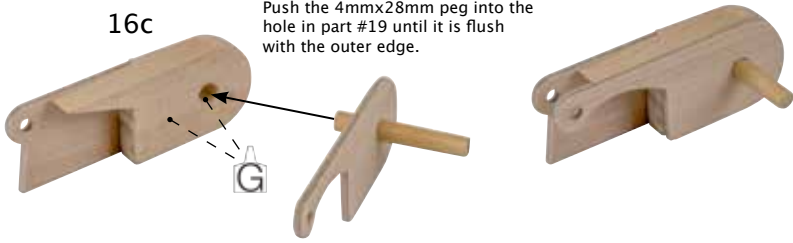

Patient Left Arm

16d

Push the 4mmx28mm peg into the hole in part #20 until it is flush with the outer edge.



17

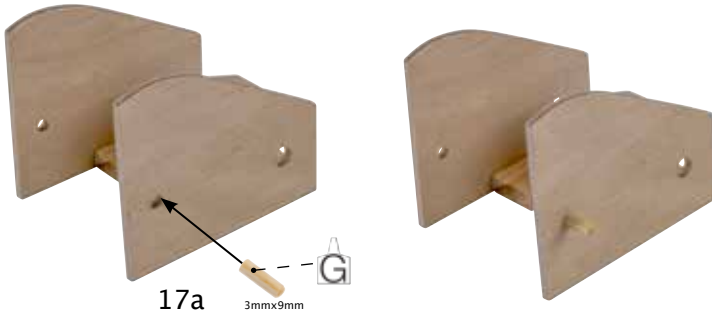

17a

3mmx9mm

17b

3mmx9mm

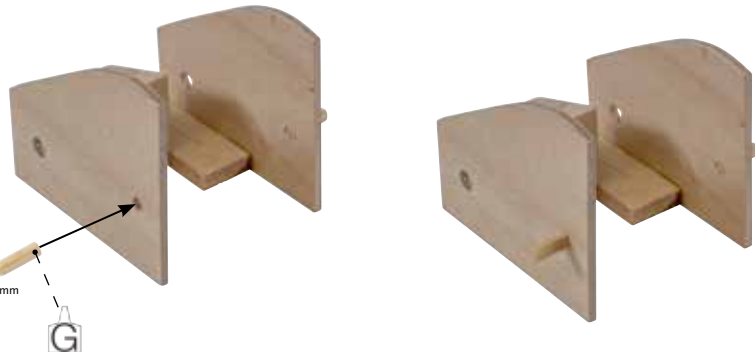

18

Patient Right Arm

22

18a

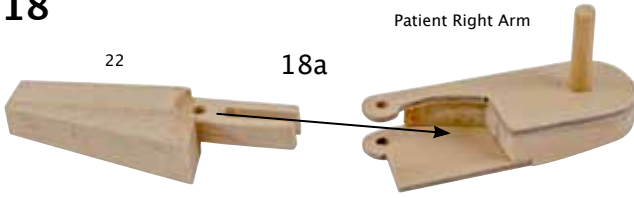

3mmx10mm

18b

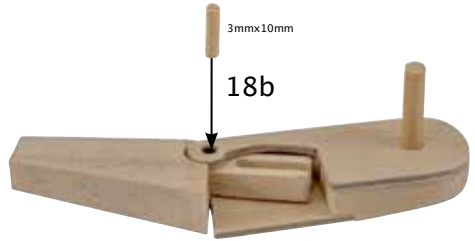

G

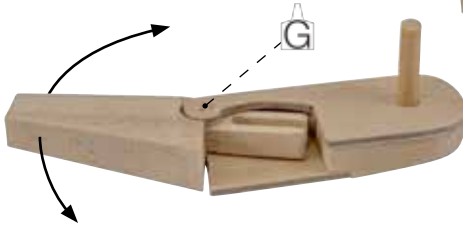

Patient Left Arm

23

18c

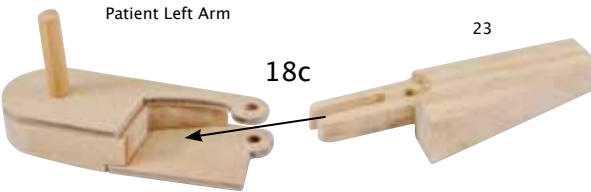

3mmx10mm

18d

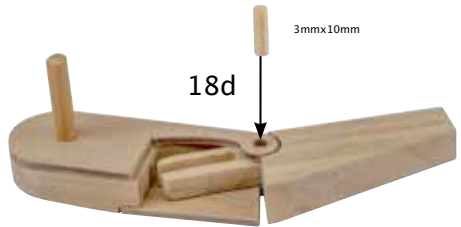

G

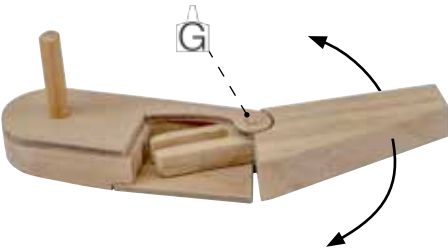

# 19

19a

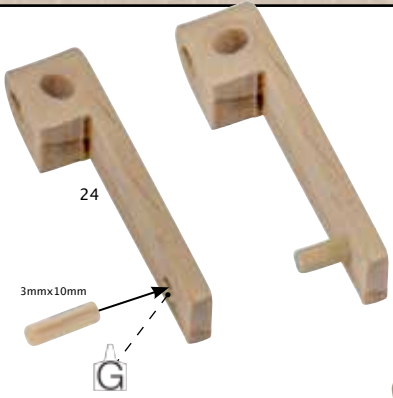

19b

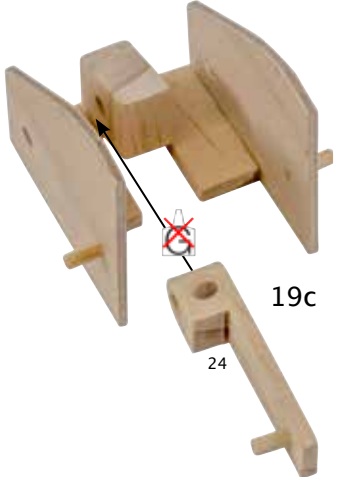
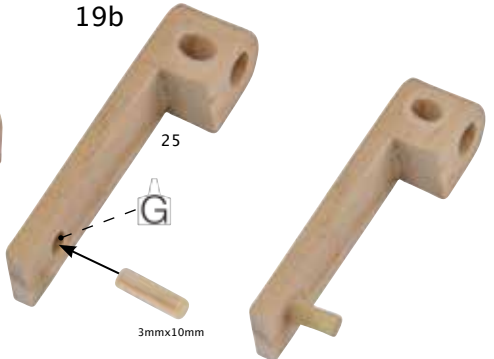

19c

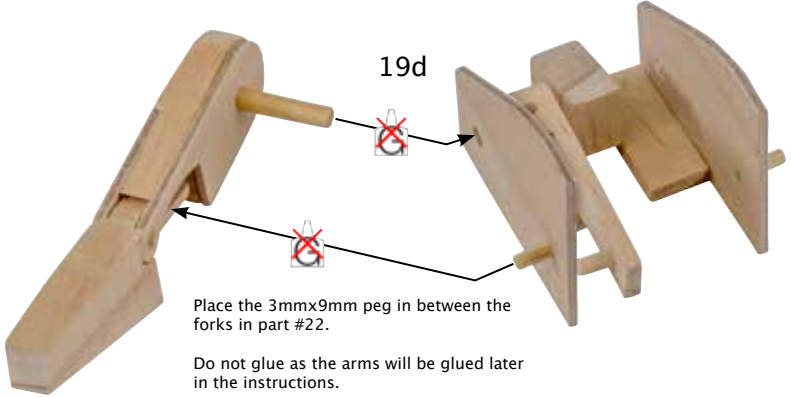

19d

Place the 3mmx9mm peg in between the forks in part #22.

Do not glue as the arms will be glued later in the instructions.



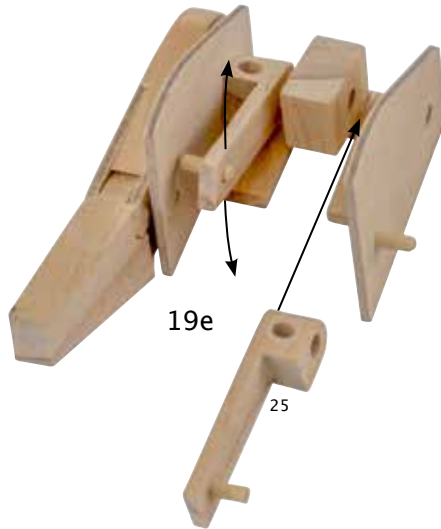

19e

25

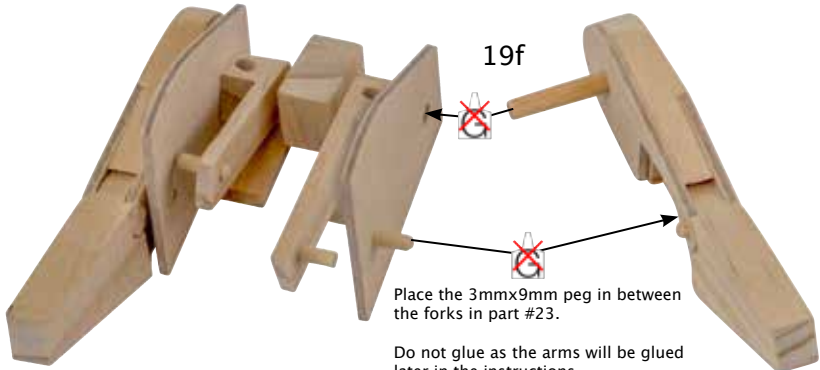

19f

Place the 3mmx9mm peg in between the forks in part #23.

Do not glue as the arms will be glued later in the instructions.

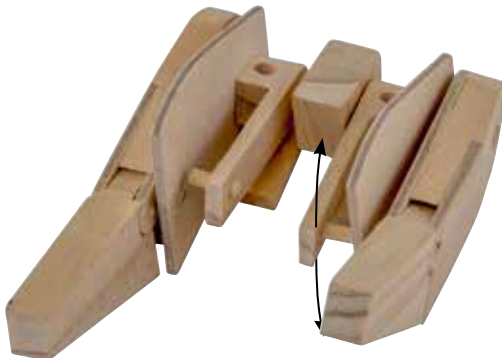

20

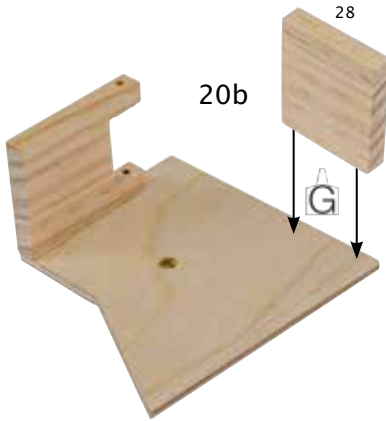
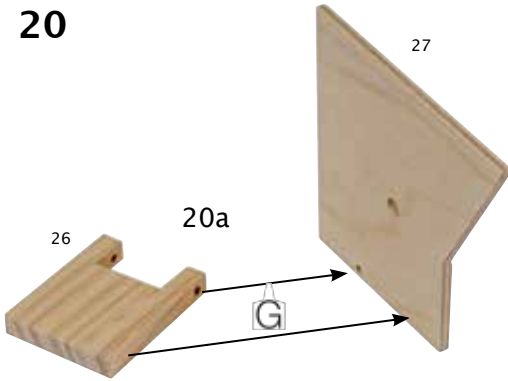

21

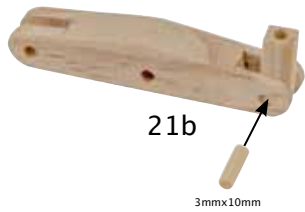

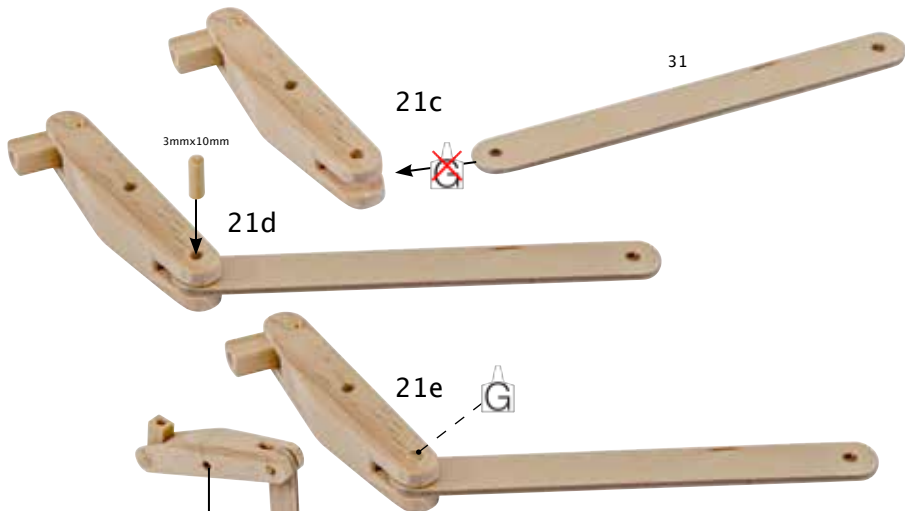

22

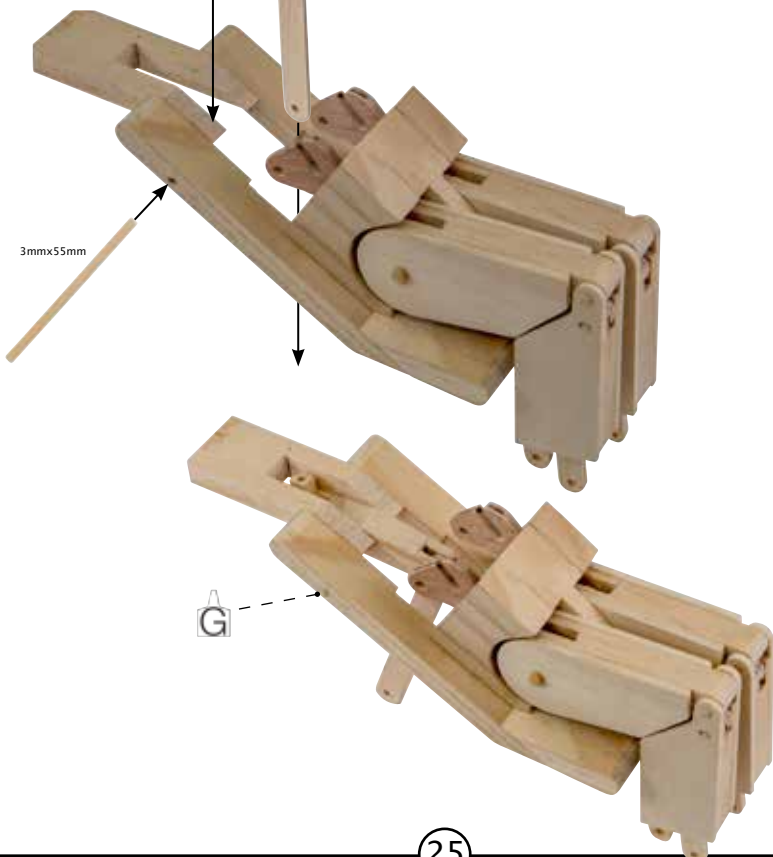

23

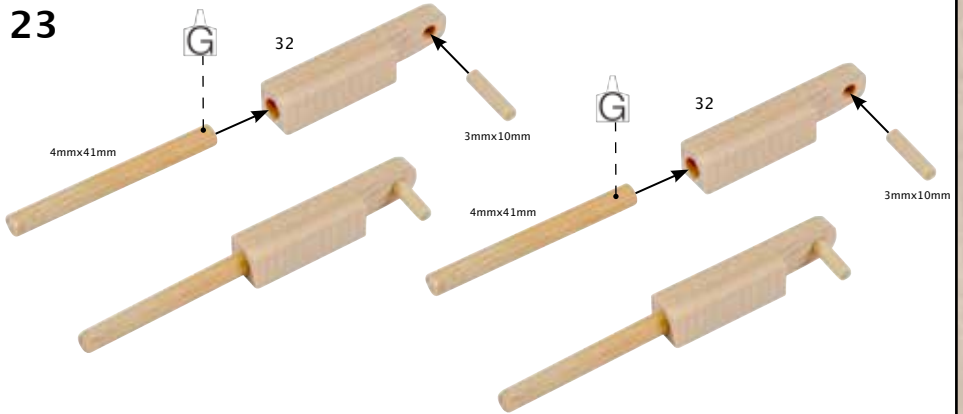

24

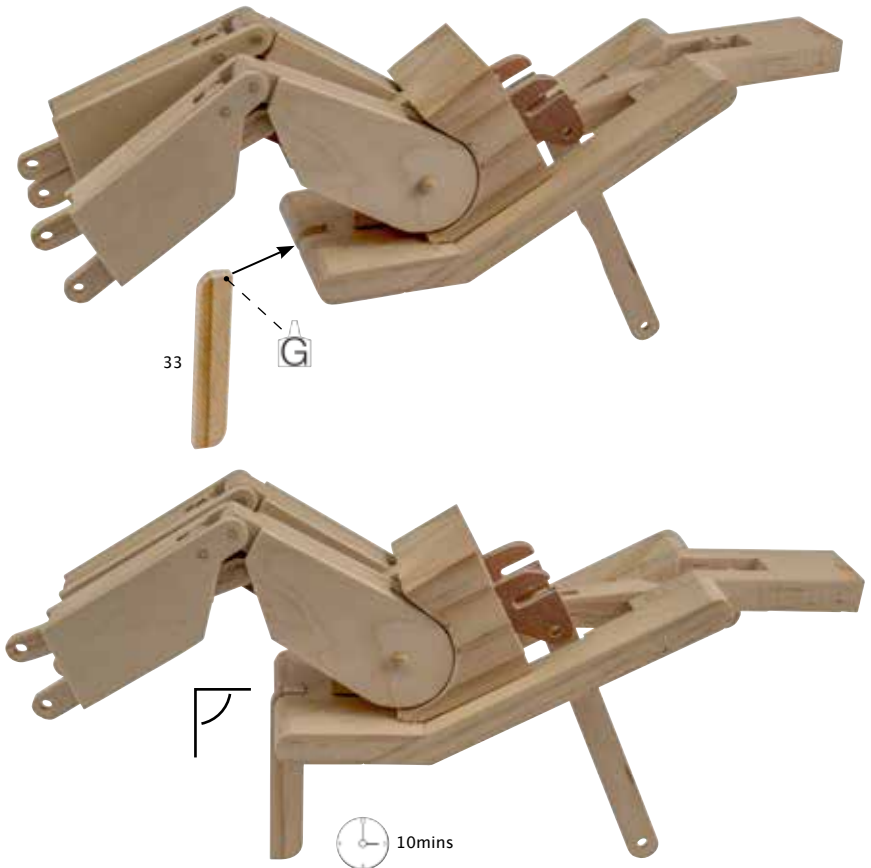

25

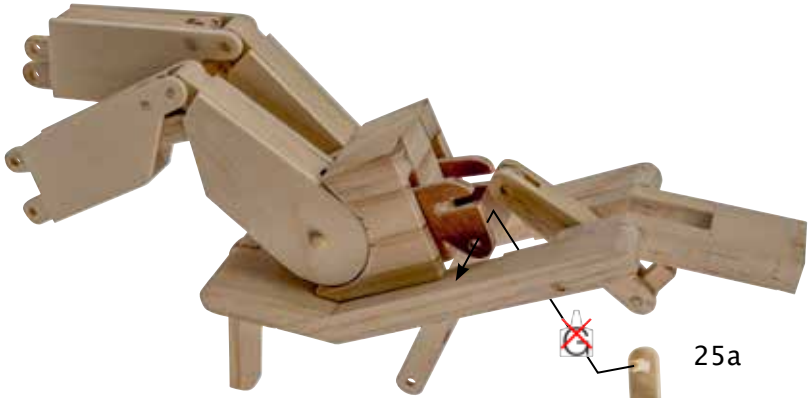

Locate the 3mmx10mm pin in part #32 in the hole beneath slot in part #4. No glue.

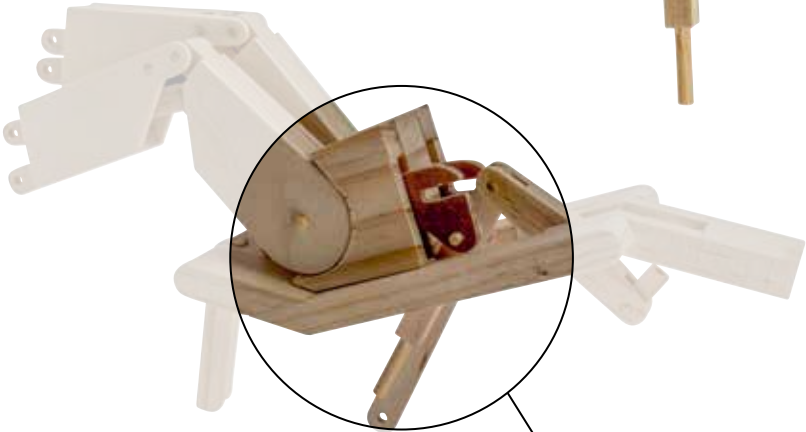



25b



Locate the 3mmx10mm pin in part #32 in the hole beneath slot in part #4. No glue.

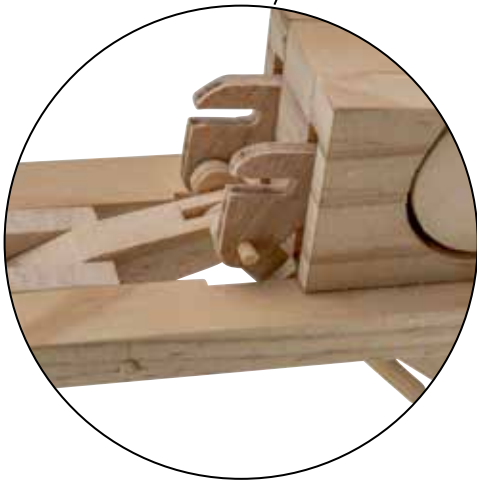
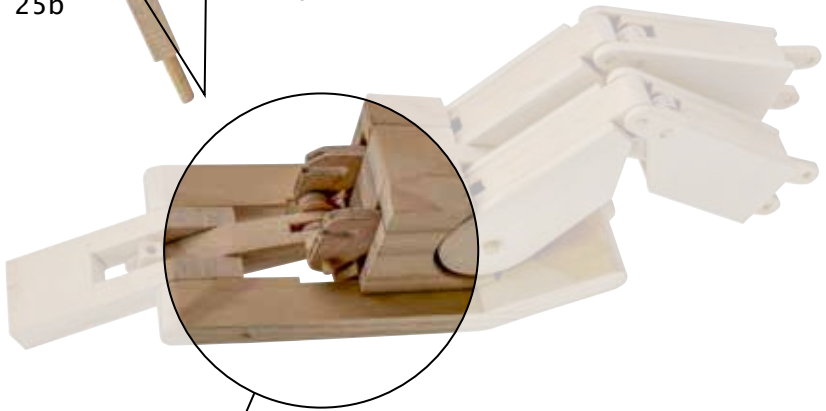

When completed you can pull on part #32 (on both sides) and the leg should lift up and down.

26

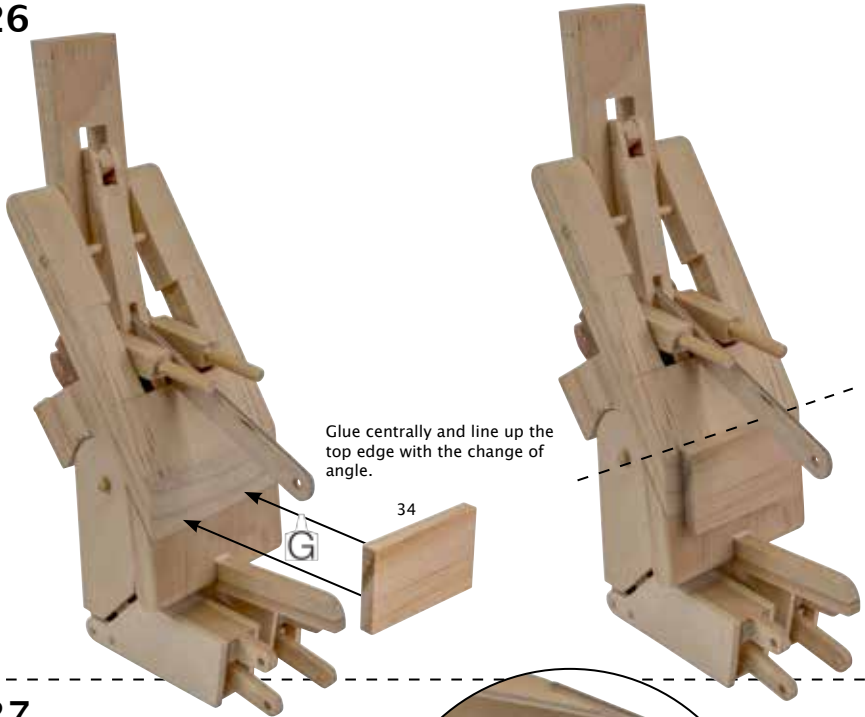

Glue centrally and line up the top edge with the change of angle.

34

27

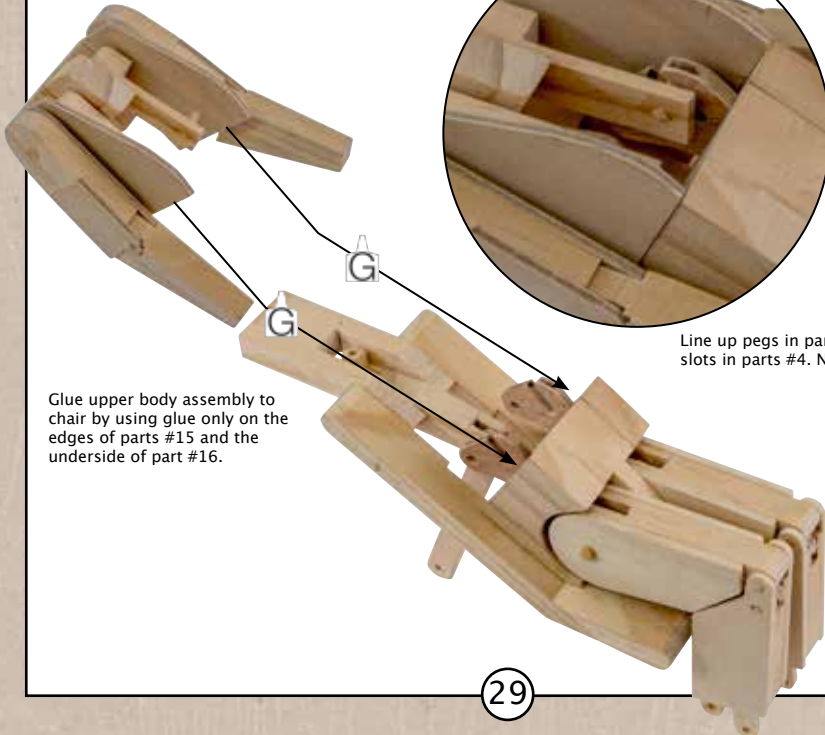

Glue upper body assembly to chair by using glue only on the edges of parts #15 and the underside of part #16.

Line up pegs in parts #24 & #25 with slots in parts #4. No glue here.



28

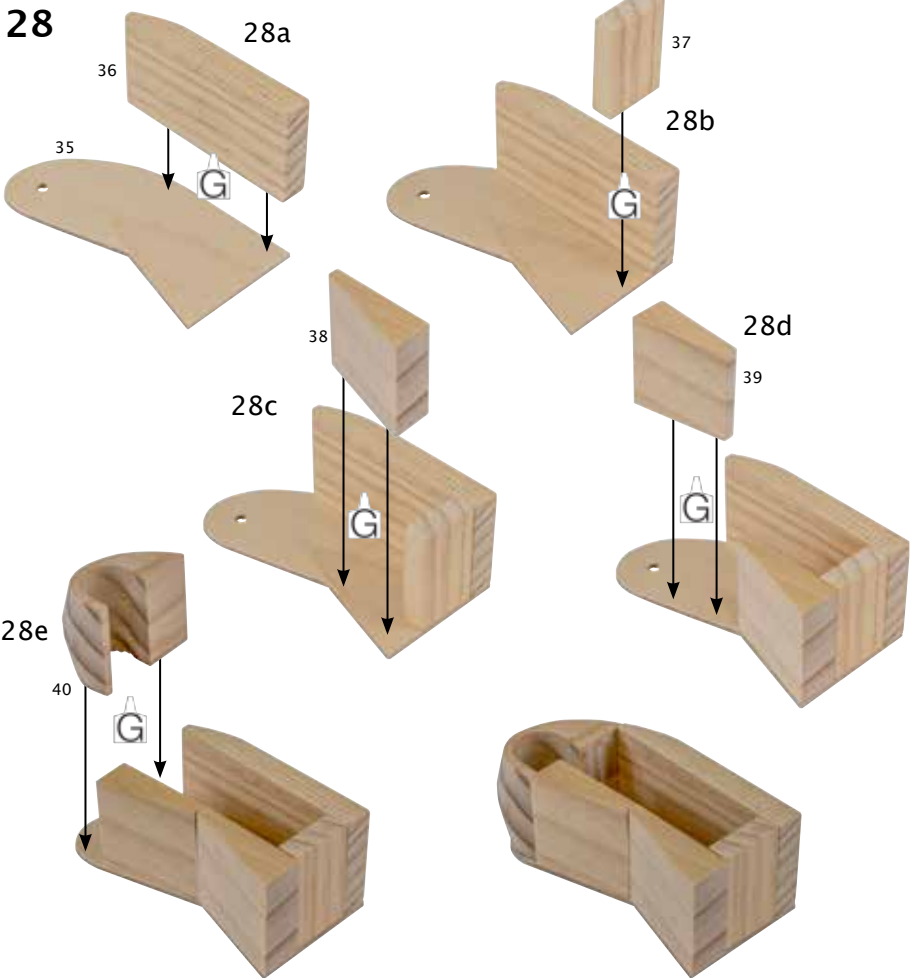



29

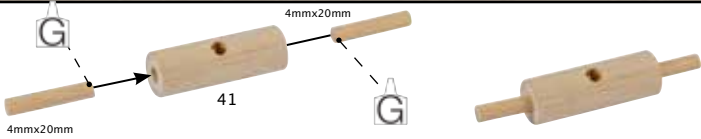

30

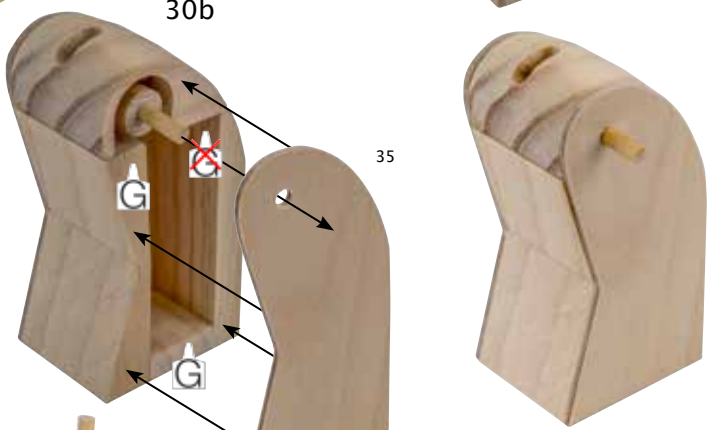
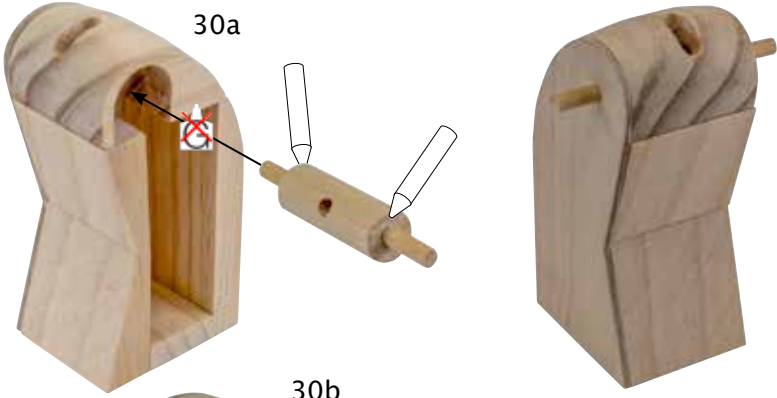

30c

Glue the 4mmx34mm peg into hole in middle of part #41. Apply glue in hole with a thin stick.

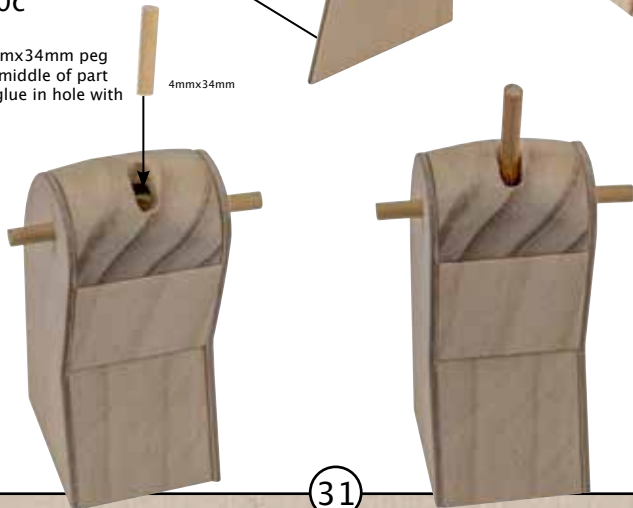

# 31

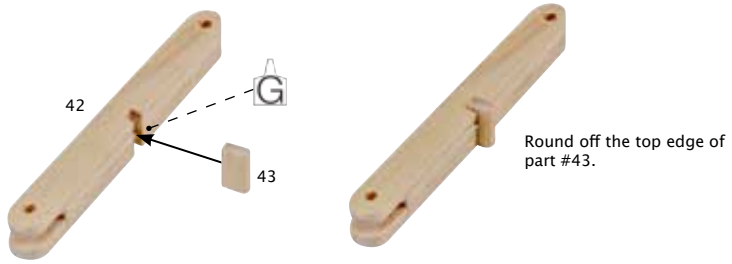

# 32

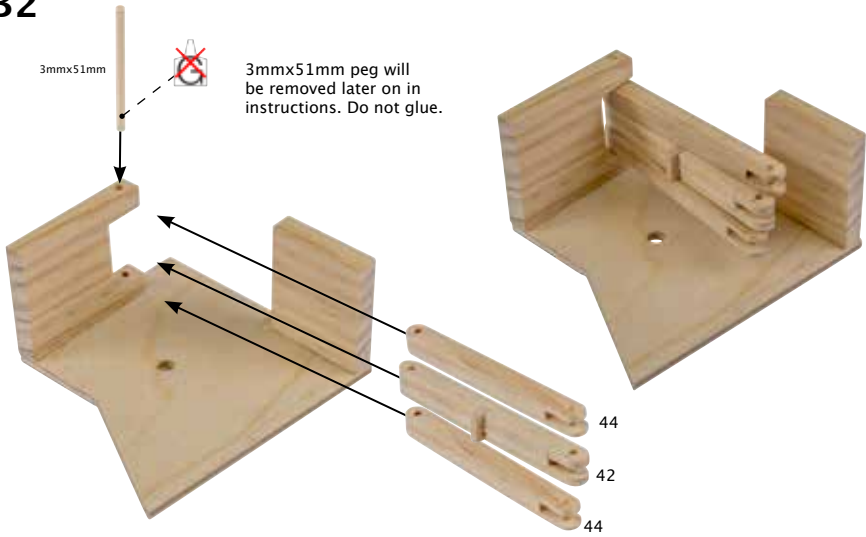

# 33

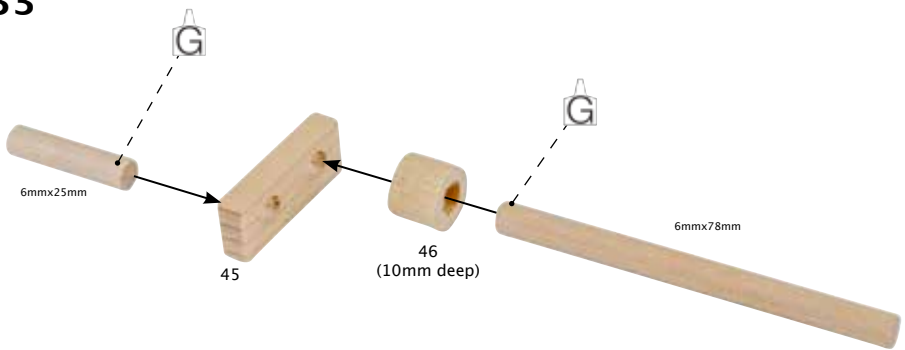

**34** This will give you a model that is easier for left-handed people to turn. For a right-handed model simply push the handle through the other side piece and thread on the various cams and spacers in reverse.

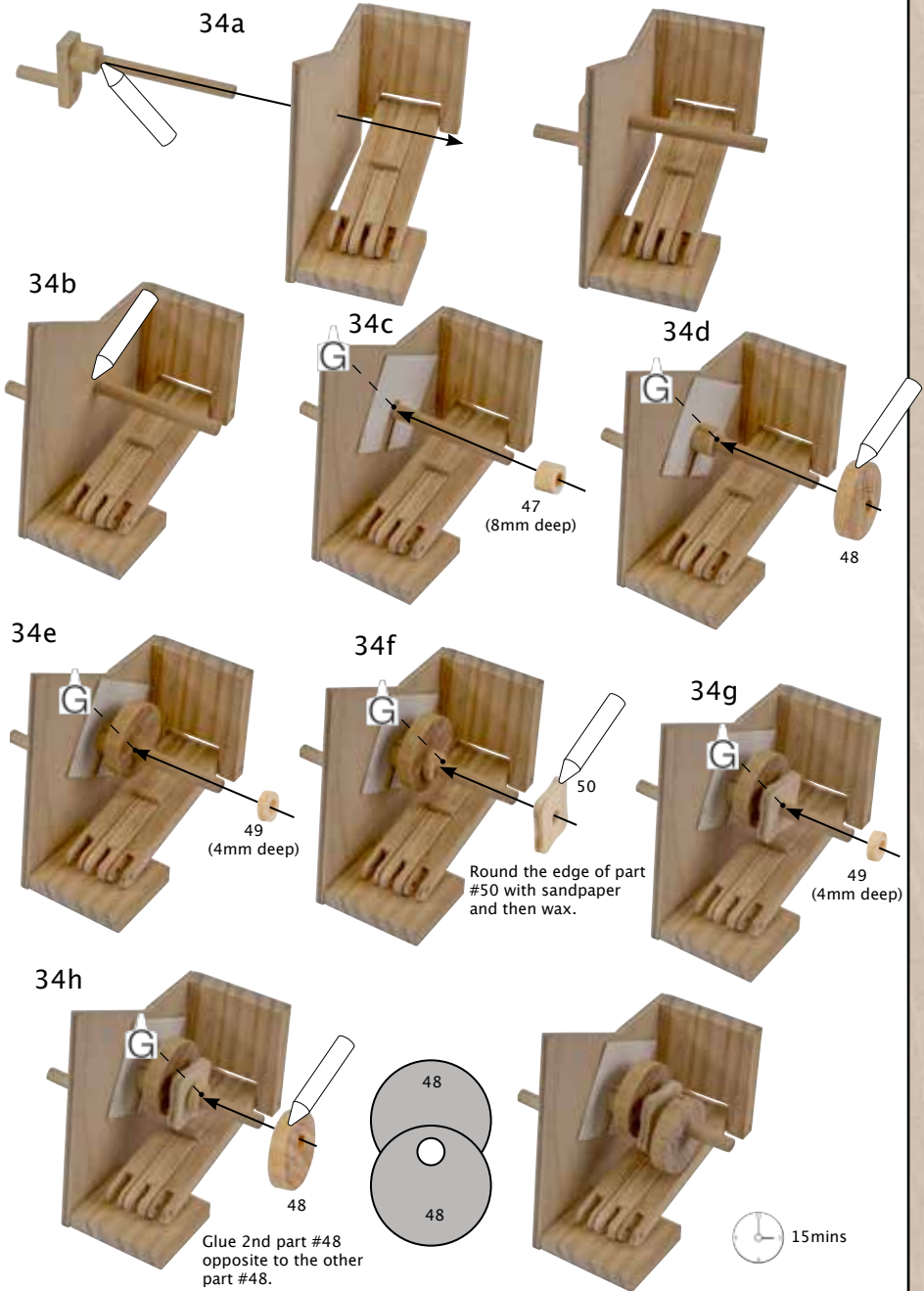

35

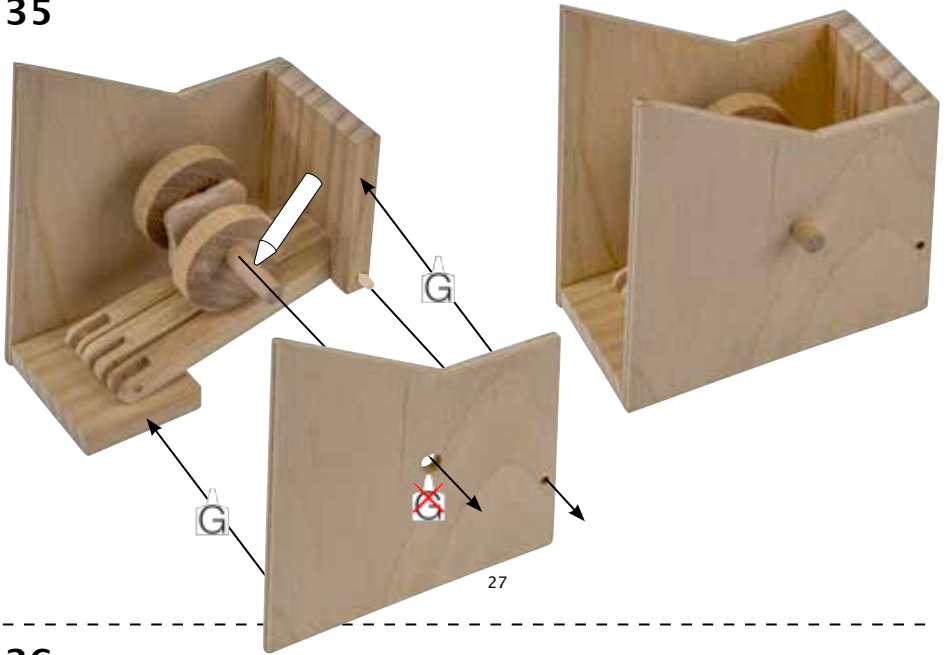

36

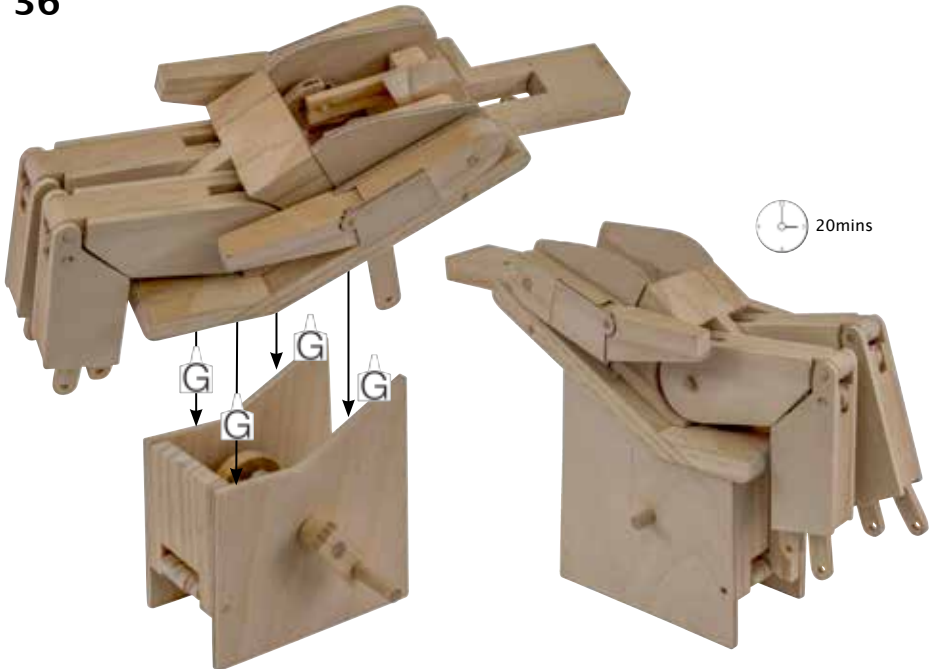

37

37a

Dentist Left Leg

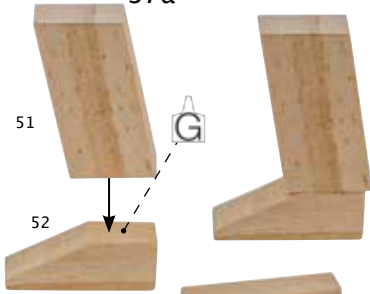

37b

Dentist Right Leg

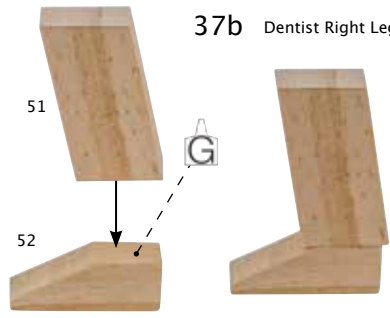

Glue each foot at opposite angles to each other.

38

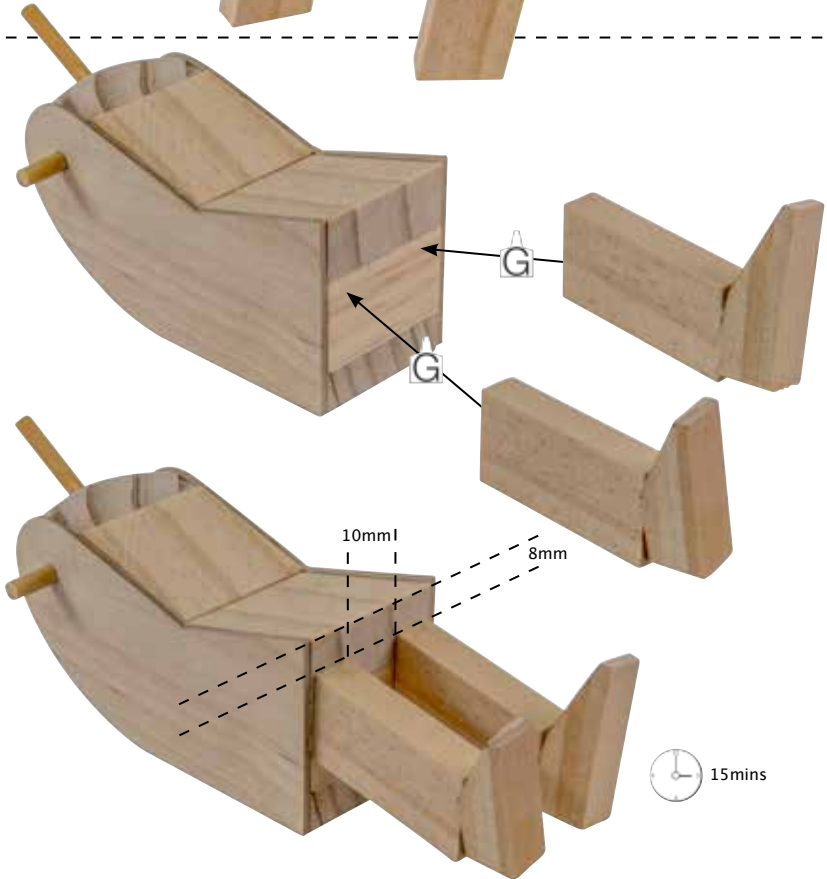

39

Dentist Right Arm

Dentist Left Arm

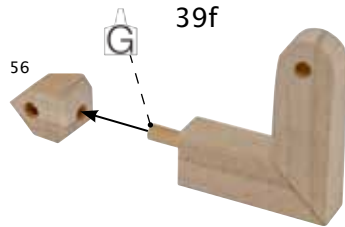
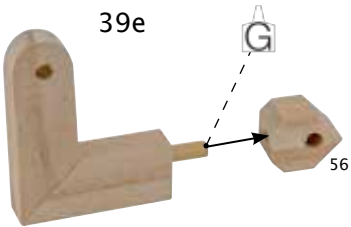
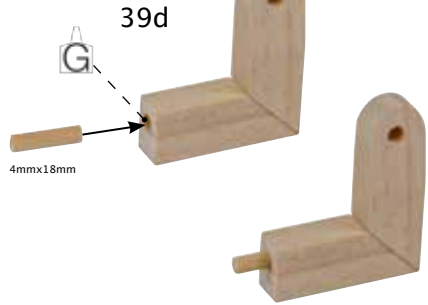
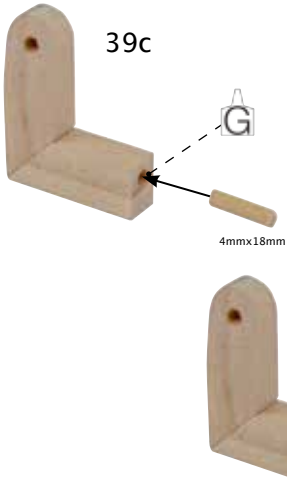
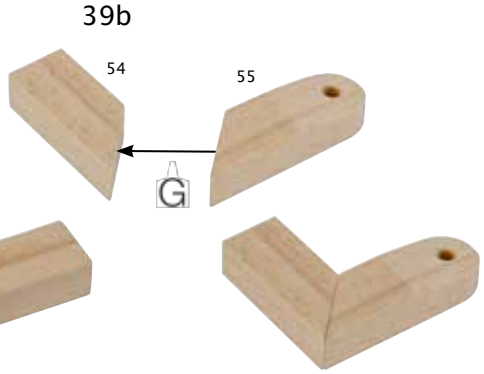
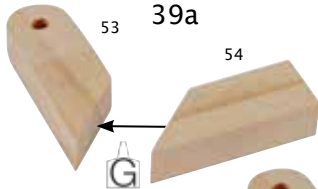

# 40

Dont push part #57 all the way down to bottom of slot.

## 40a

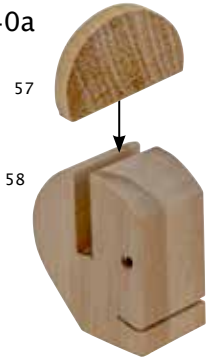

## 40b

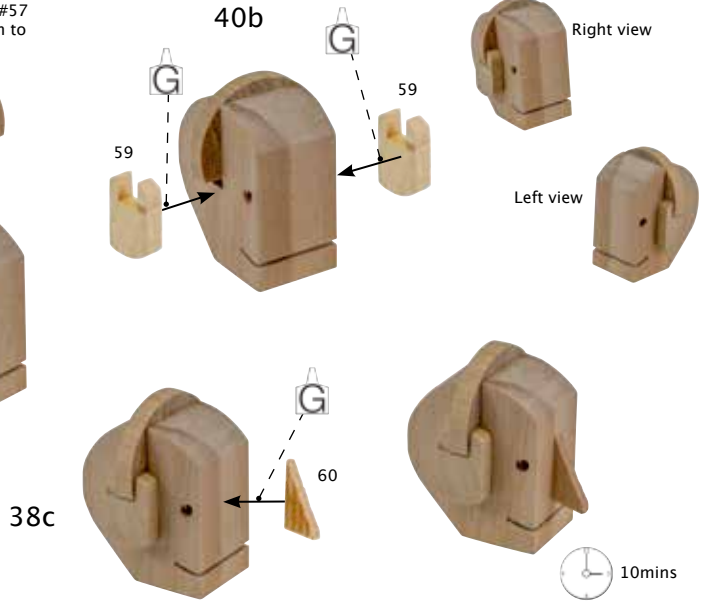

# 41

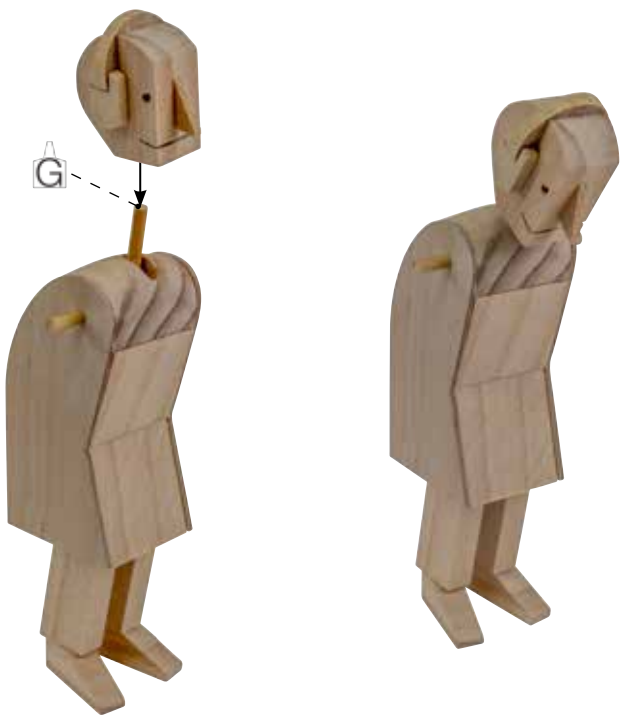

42

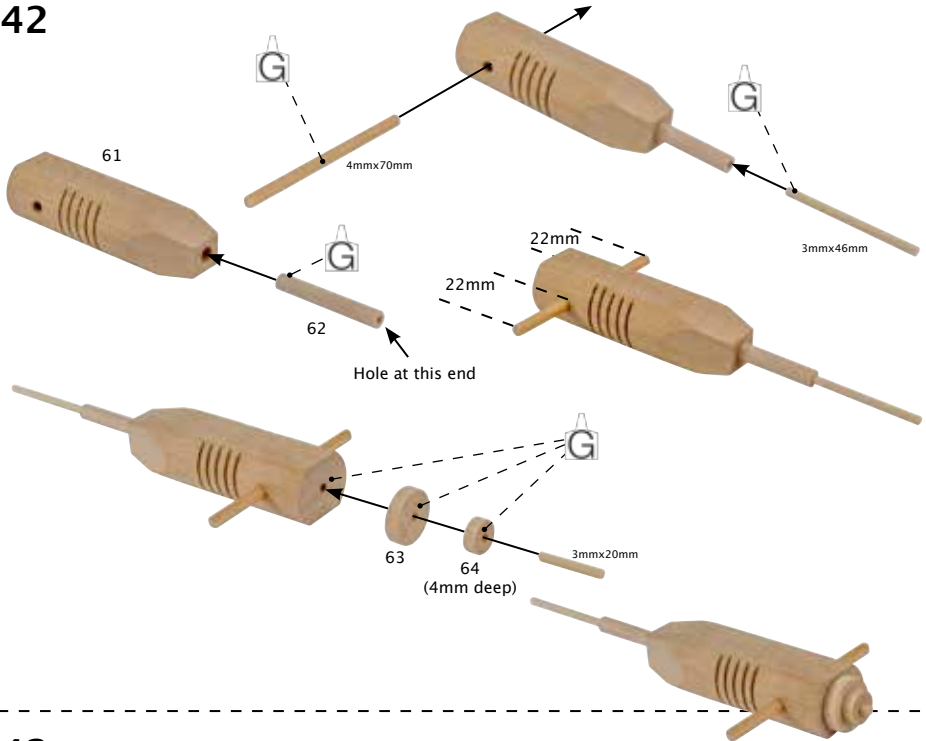

43

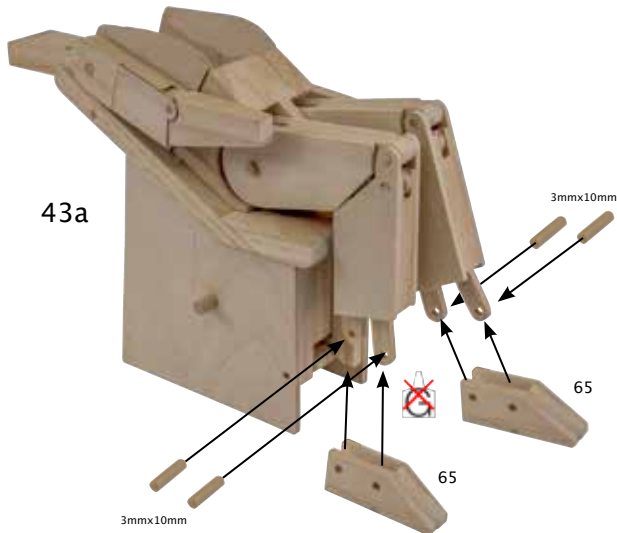



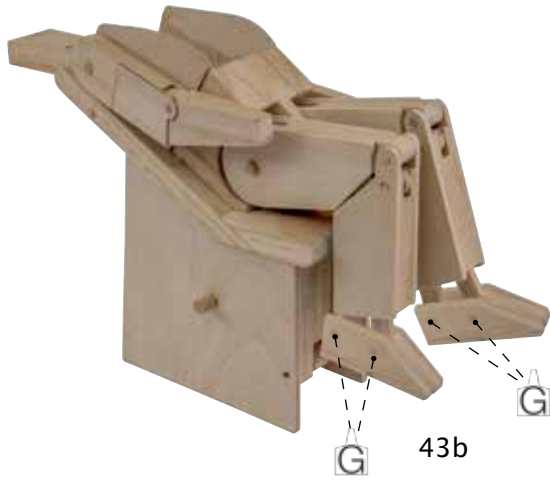

44

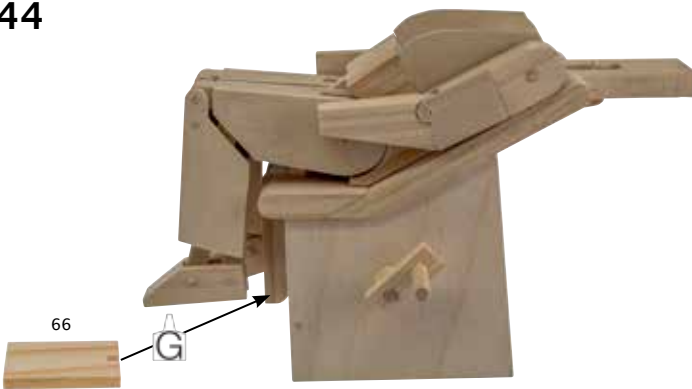

Glue part #66 in place when both feet are level on it.

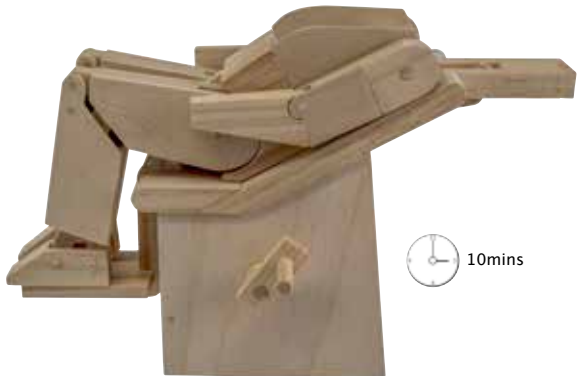

45

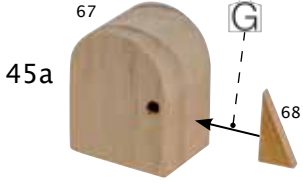

45a



Teeth are all 3mmx10mm

45c

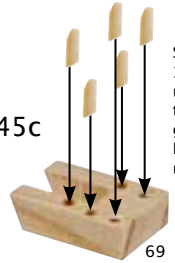

Sand the 3mmx10mm pegs used for the teeth to a point before gluing into holes. Pegs should be uneven for effect.

Teeth are all 3mmx10mm

45b

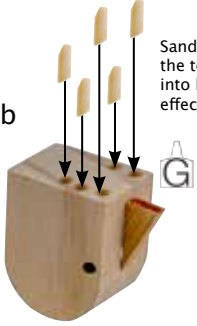

Sand the 3mmx10mm pegs used for the teeth to a point before gluing into holes. Pegs should be uneven for effect.

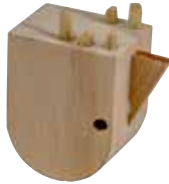

46



Remove 3mmx51mm pin from side of base and pull out all of the levers 44, 42 & 44 before proceeding to next stage.

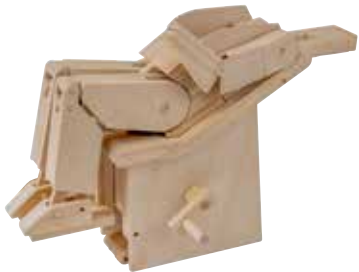
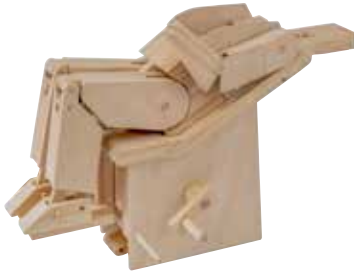

47

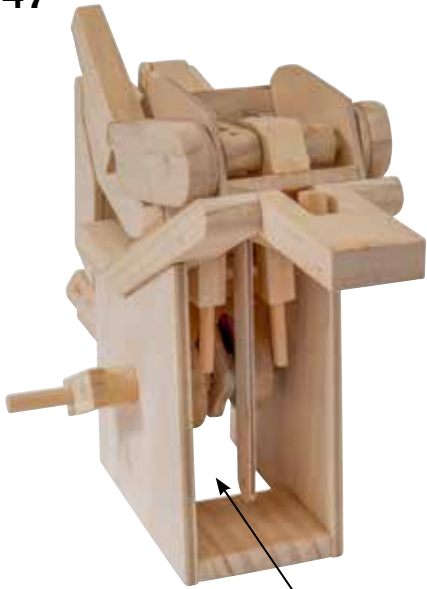

47a

42

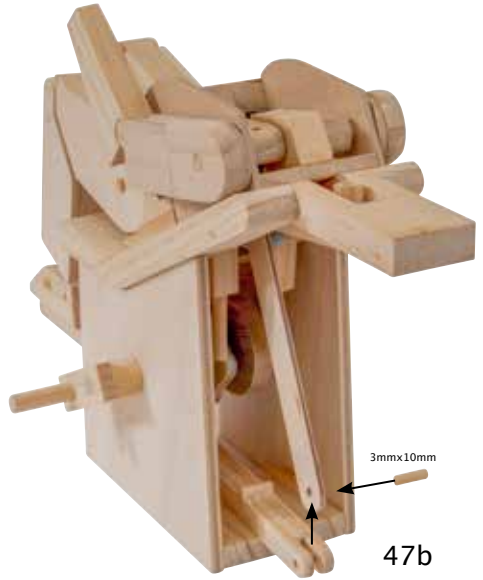

3mmx10mm

47b

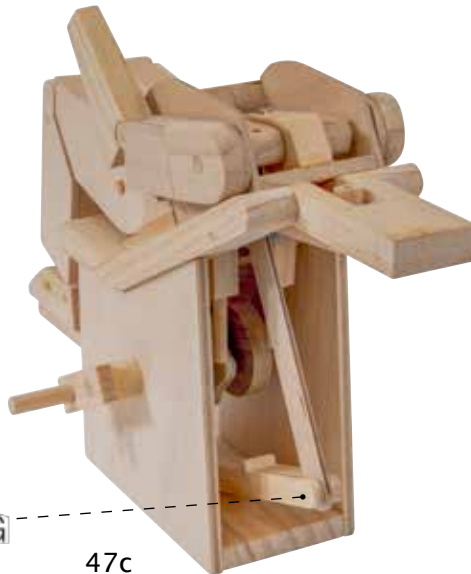

G

47c

48

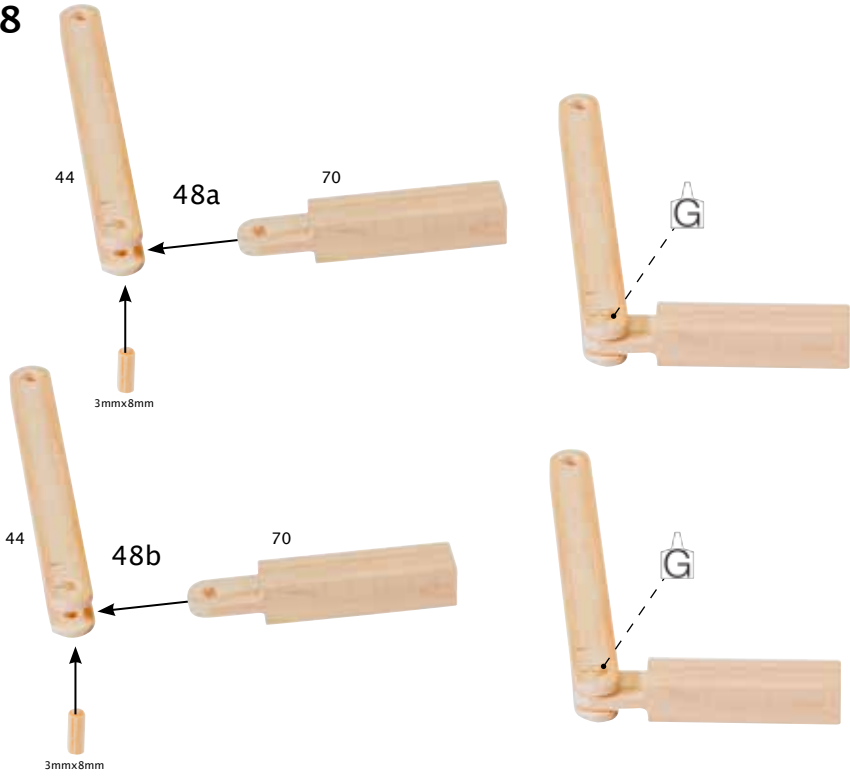

49

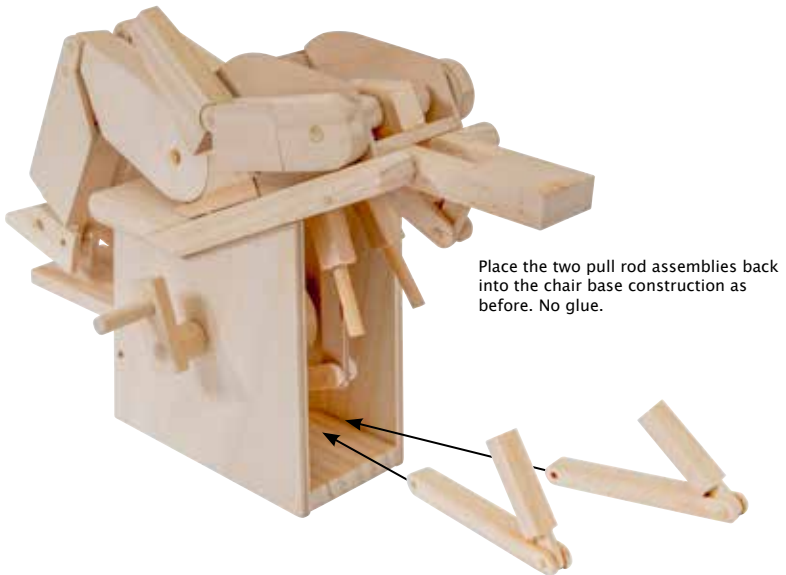

Model viewed from other end.

Replace the 3mmx51mm peg back through 3mm hole at the ends of parts #44, 42,44 as before.

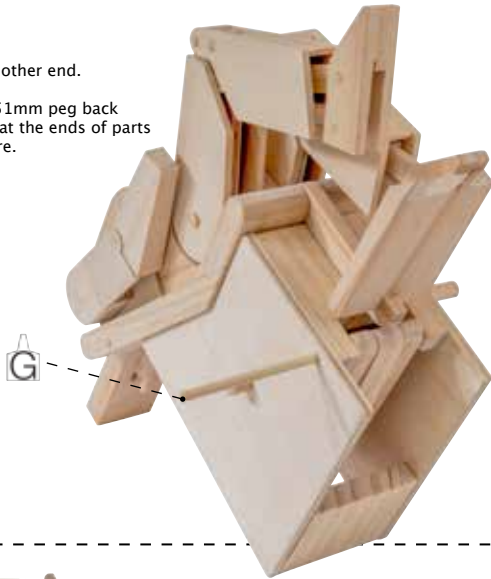

50

Fill with glue the 4mm hole on the end of one of the part #70's and push the 4mm x 41mm peg protruding from the part #32 above it into the glue filled hole. You might have to gently press on the top of part #4 to help with this. Wait for a short time until the glue is tacky and then slowly turn the handle until the offset cam (part #48) that is in line with what you have just glued has been in its lowest position and the 4mm x 41mm peg has been adjusted to accommodate this. The handle should be able to revolve freely with no tight spots.

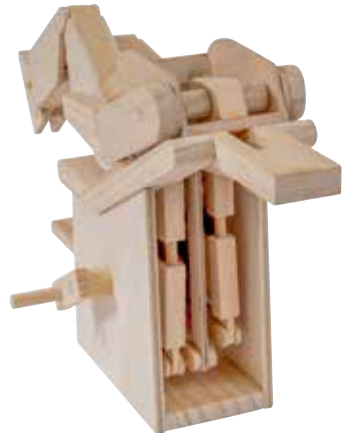
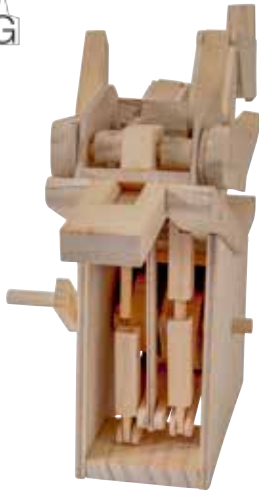
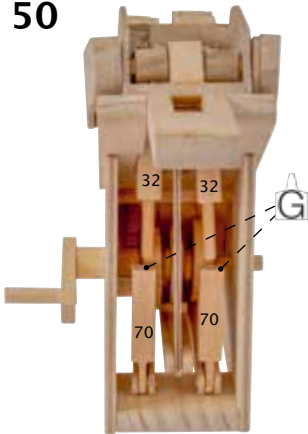

Repeat this whole process with the other part #70 and part #32.

# 51

51a

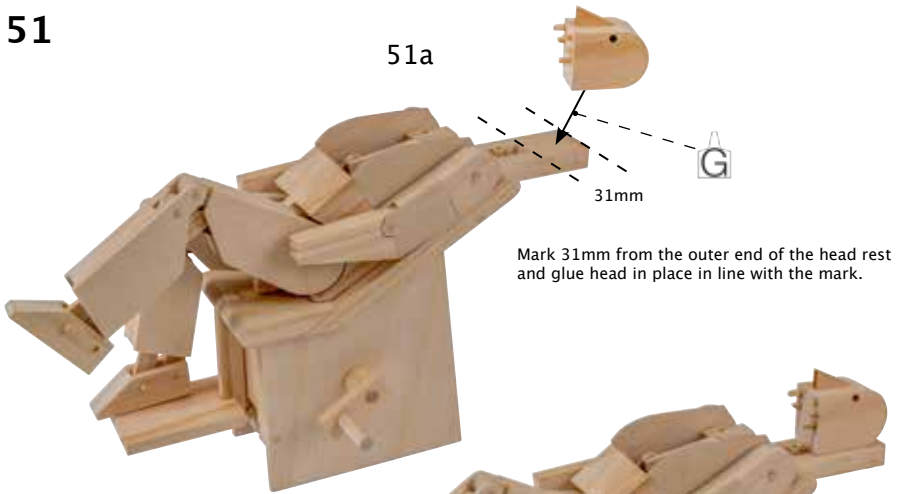

Mark 31mm from the outer end of the head rest and glue head in place in line with the mark.

51b

Glue lower jaw in place with a 2mm gap between the upper jaw.



52

Fill hole in top of part 24 with glue (If you have superglue put a small amount in the hole before putting in the wood glue) then use a cocktail stick to really push it down into the hole whilst moving the arm up and down. Top up with more glue, re-engage the elbow pin in the fork if necessary.

Turn handle gently until right leg is in the highest position. Then gently press the upper arm down until it reaches its lowest position. Leave to dry for 2 hours.

Repeat for other arm.

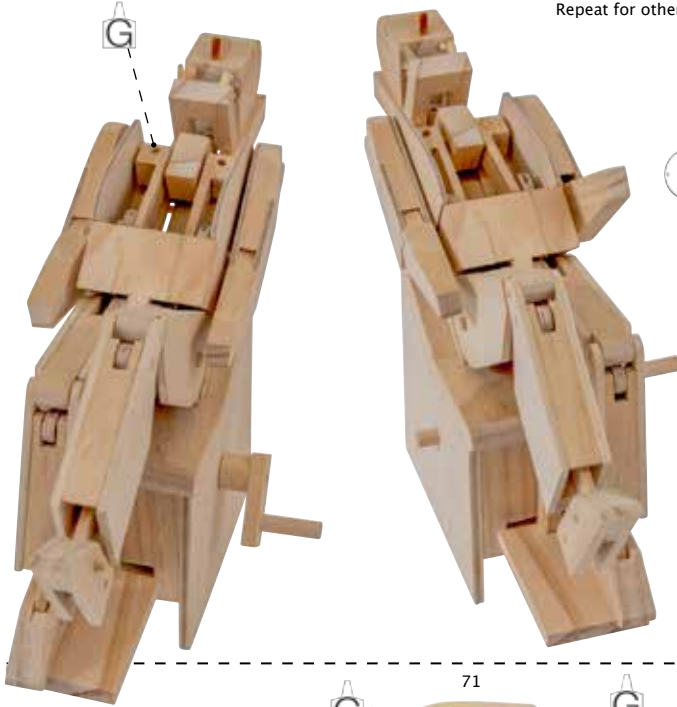

53



54



55



55a

Side view

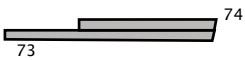

Left hand

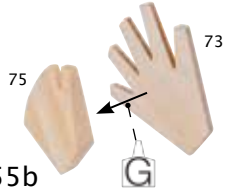

55b

Side view



Right hand

Sand a small angle by each wrist as shown so that the hands splay outwards when glued in place.



56

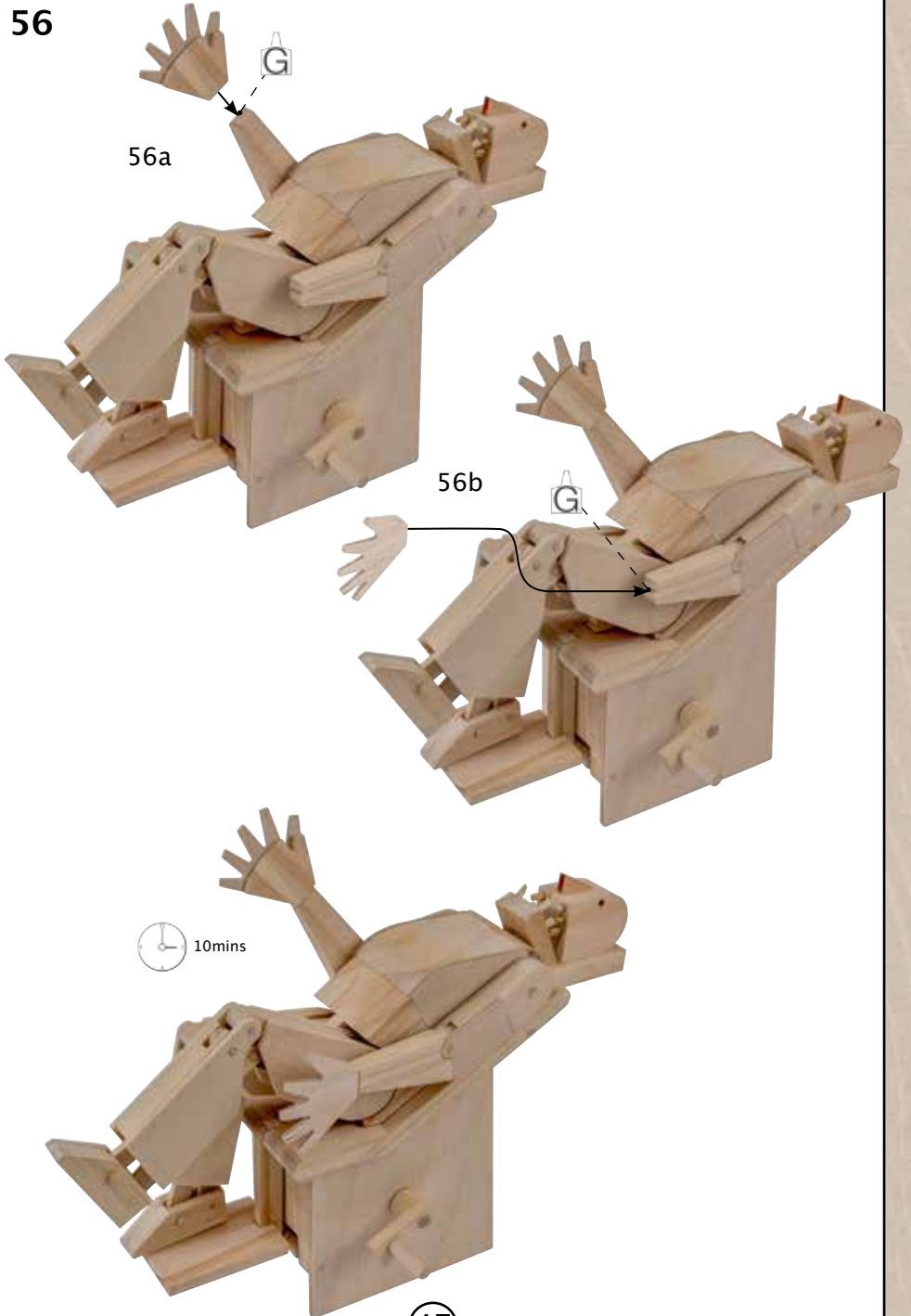

57

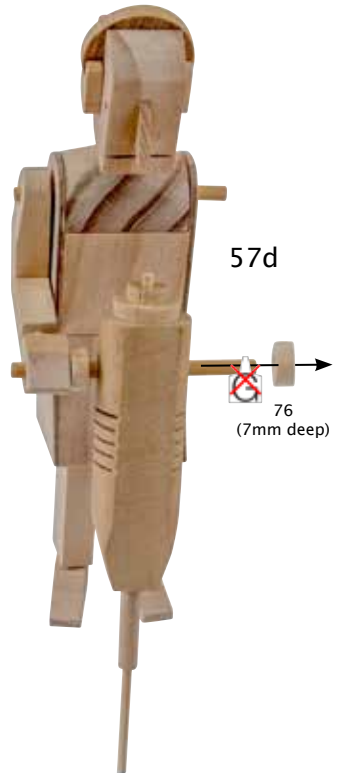
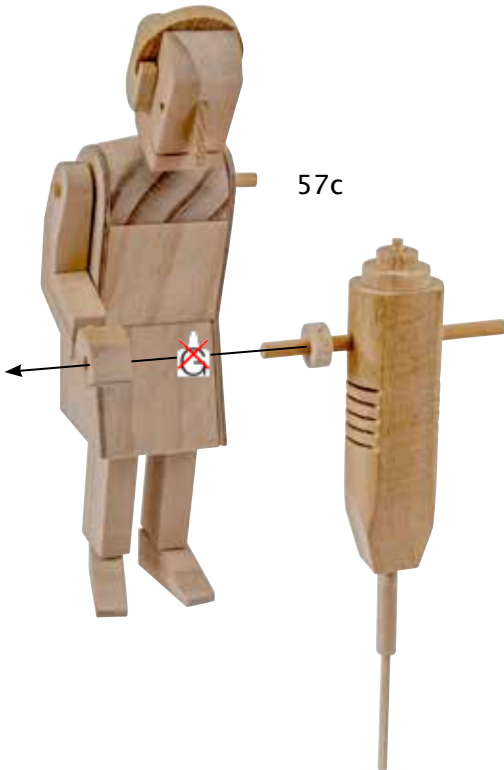
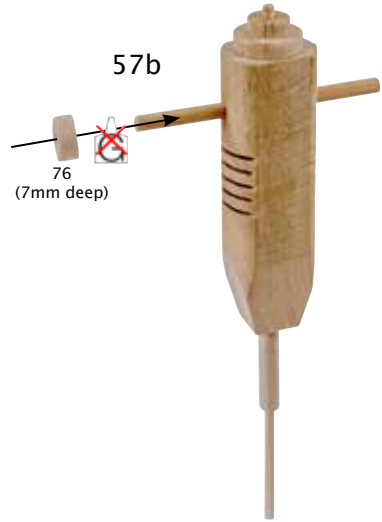
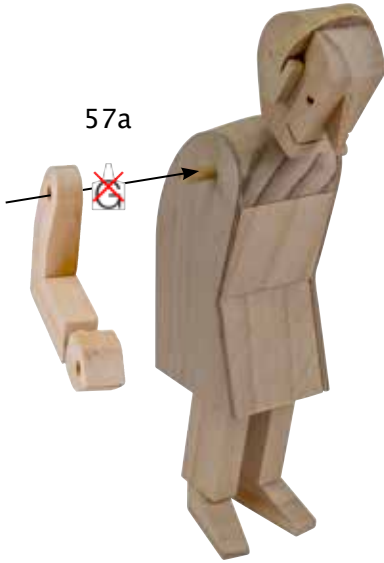

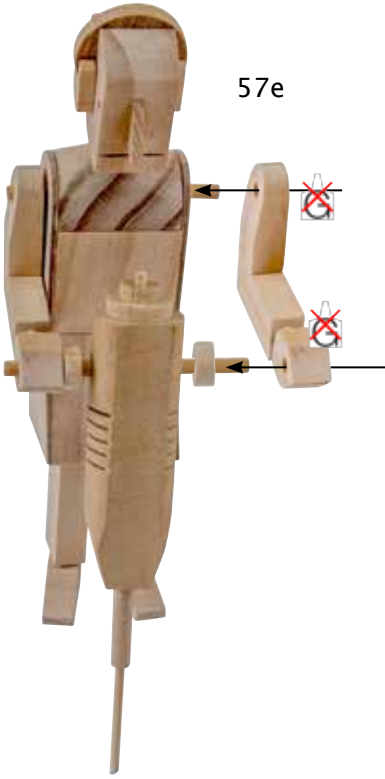

58

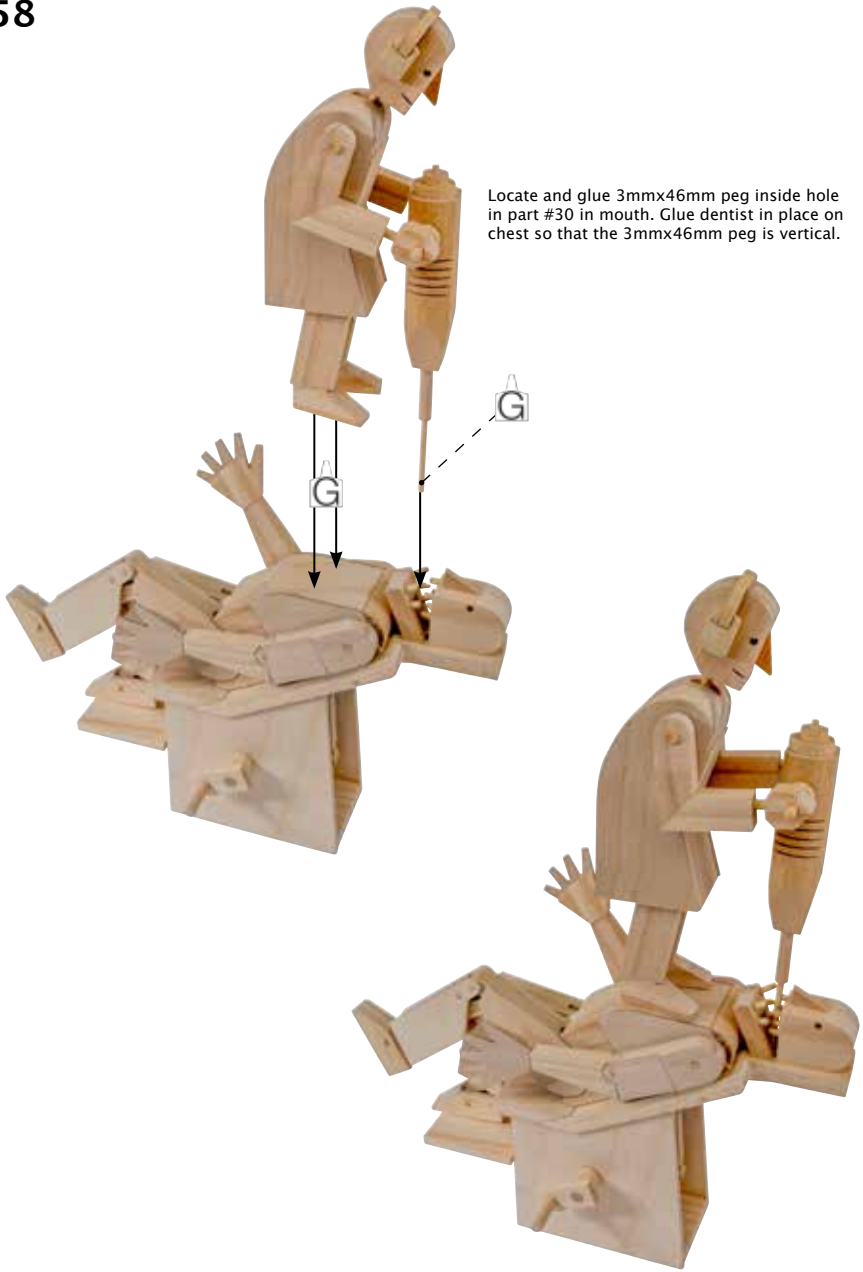

Locate and glue 3mmx46mm peg inside hole in part #30 in mouth. Glue dentist in place on chest so that the 3mmx46mm peg is vertical.

59

Remove arms and put a dab of glue inside both shoulder holes, then re-position arms in place.

Before glue dries turn handle and adjust arm position and head. The 'nod' needs to work in sync with arms.



60

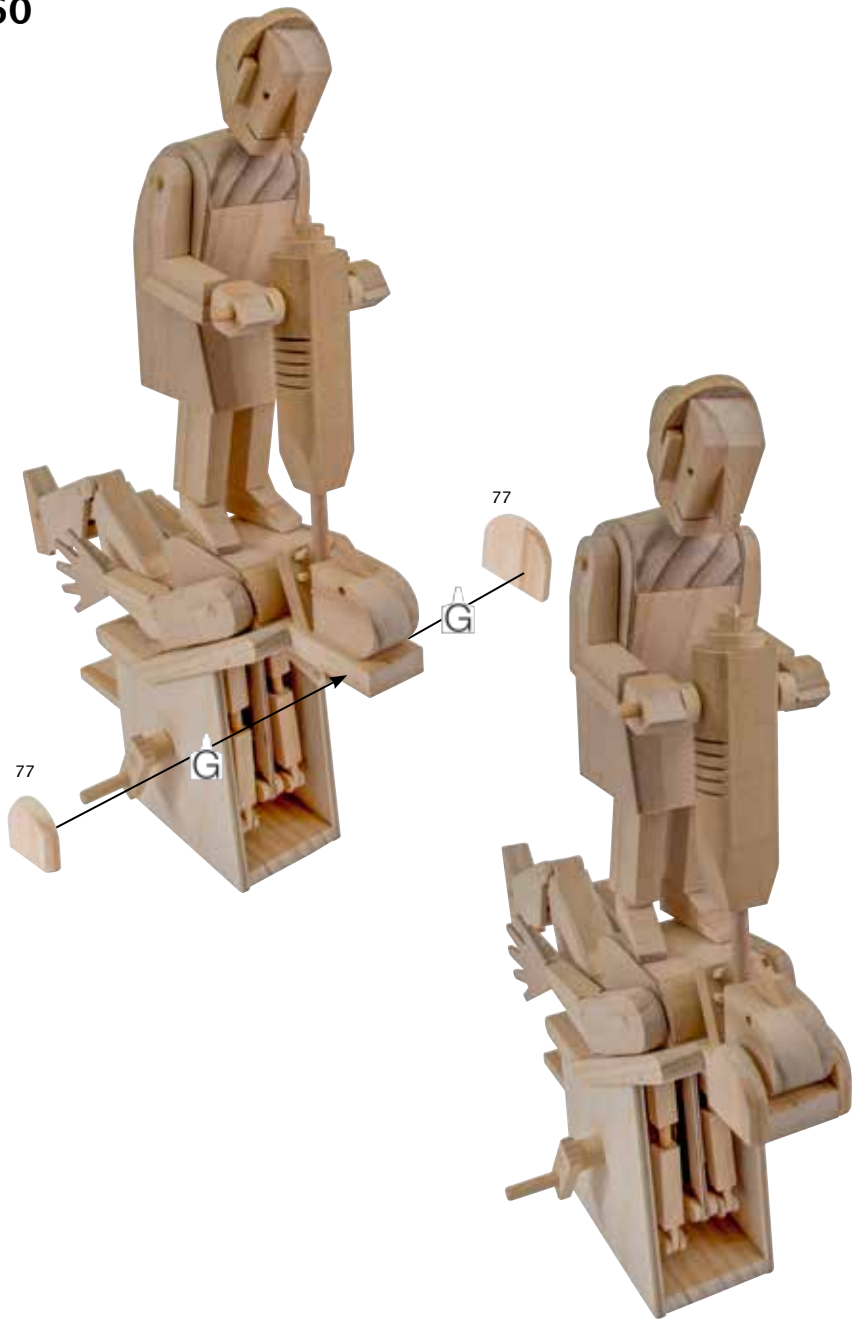

- (UK) If you enjoyed building this model why not try our others. Available directly from Timberkits Ltd or from our UK, European or worldwide retail partners. Check our website to find your nearest stockist.
- (FR) Si vous avez apprécié construire ce modèle, pourquoi ne pas en essayer d'autres. Ils sont disponibles chez Timberkits Ltd ou chez nos partenaires détaillants au Royaume Uni, en Europe et plus largement dans le monde.
- (SP) Si te has divertido con este modelo, porque no pruebas los ademas. Estan todos disponibles directamente desde Timberkit Ltd o desde las nuestra tiendas en Reino Unido, Europa o en otros continentes. Visita el nuestro sitio web para conocer el punto vendita mas cercano.
- (IT) Se ti sei entusiasmato a costruire questo modello, perche non provare gli altri. Sono disponibili direttamente dalla Timberkits Ltd oppure dai nostri rivenditori in Gran Bretagna, Europa e altri continenti. Visita il nostro sito web per trovare il più vicino punto vendita.
- (DE) Wenn sie Freude daran hatten, dieses modell zu bauen, wieso nicht die anderen ausprobieren. Sie können direkt bei Timberkits Ltd bestellen oder bei unseren handelspartnern in Großbritannien, Europa und weltweit. Besuchen sie unsere webseite für ihren nächstgelegenen händ-ler.

[www.timberkits.com](http://www.timberkits.com)



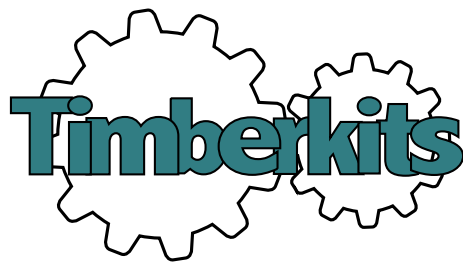

Timberkits Limited  
Old Village Hall  
Llanbrynmair  
Powys, SY19 7AA  
00 (44) (0) 1650 521635  
timber\_kits@btconnect.com  
www.timberkits.com

Timberkits logo and all Timberkits designs are Copyright (©) 2012 all rights reserved.

