

AP1520VS

Oscillating Bobbin Sander



Axminster Stand for AP150OVS

Code 106070



Cert No: OVS-TG

Axminster Tool Centre Ltd
Axminster Devon
EX13 5PH UK
axminstertools.com

declares that the machinery described:-

Type	Oscillating Sander
Model	AP152OVS

Signed



Andrew Parkhouse
Operations Director

Date: **08/04/2025**

EU Declaration of Conformity

This machine complies with the following directives:

2006/42/EC
2014/35/EU
EN ISO 12100:2010
EN 60204-1:2018

and conforms to the machinery example for which the
EC Type-Examination Certificate No 685-C1-32015.R1
has been issued by **MAO SHAN MACHINERY INDUSTRIAL CO., LTD.**
at: No. 45 Yichang E. Rd., Taiping District, Taichung City 41163, Taiwan
and complies with the relevant essential health and safety requirements.

TABLE OF CONTENTS

Table of contents	1
Safety rules	2
Specifications	3
Machine legend	3
Machine dimension	4
Safe operating position	4
Instructions for operations	5
Tilting the table	5
Mounting spindle drum	6
Selection guide for drum to table insert	7
Maintenance of spindle sander	8
Troubleshooting	9
Assembly diagram	10

SAFETY RULES

Read carefully before operating the machine

1. Learn the machine's applications and limitations, as well as the specific potential hazards particular to this machine. Follow available safety instructions and safety rules carefully.
2. Keep working area clean and be sure adequate lighting is available.
3. Do not wear loose clothing, gloves, bracelets, necklaces, or ornament. Wear face, eye, ear, respiratory and body protection devices, as indicated for the operation or environment.
4. Keep hands well away from cutter head and all moving parts. Do not clear chips and sawdust away with hands. Use a brush.
5. Make sure the spindles are moving at operation speed before sanding.
6. Do not push the sanding spindles to hard. The spindles will perform better and be safer working at the rate for which it was designed.
7. Whenever possible use a dust collector with shaving hood to minimize health hazards.
8. Never leave the machine with the power on.
9. Keep children away. Make sure that visitors are kept at a safe distance from the work area.
10. Use recommended speed sanding accessory, and workpiece material.
11. Never stand on tool. Serious injury could occur if the tool is tipped or if the sanding tool is unintentionally contacted.
12. Be sure sanding spindles are securely locked in the machine.
13. Use suitable support if stock does not have a flat surface.
14. Keep guards in place and in working order. If a guard must be removed for maintenance or cleaning make sure it is properly attached before using the tool again.
15. Be sure that key and adjusting wrenches have been removed before turning power on.
16. Only use accessories designed for the machine. Use of accessories not recommended by may result in a risk of injury.
17. Make sure tool is properly grounded. If tool is equipped with three-prong plug, it should be plugged into a three-pole electrical receptacle. Never remove the third prong.
18. Always disconnect tool before servicing and when changing accessories such as spindle sizes.
19. To make sure the cover of the magnetic switch has covered up before the machine electrified.
20. Hold material firmly against the table.
21. Do not use this spindle sander for other than it's intended use. If used for other purposes, disclaims any real or implied warranty and holds itself harmless for any injury, which may result from that use.

SPECIFICATIONS

Code	107635
Model	AP152OVS
Rating	Professional
Power	375W 230V 50Hz 1Ph
Spindle Speed	1,425 rpm
Drum Speed	1,500 rpm
Oscillation Per Minute	29
Stroke	24 mm
Max Cap @ 90	110 mm
Height of Bobbins	140 mm & 152 mm
Table Height	465 mm
Table Tilt	0 - 45°
Table Size	370 x 370 mm
Dust Extraction	50 mm
Weight	30 kg

MACHINE LEGEND

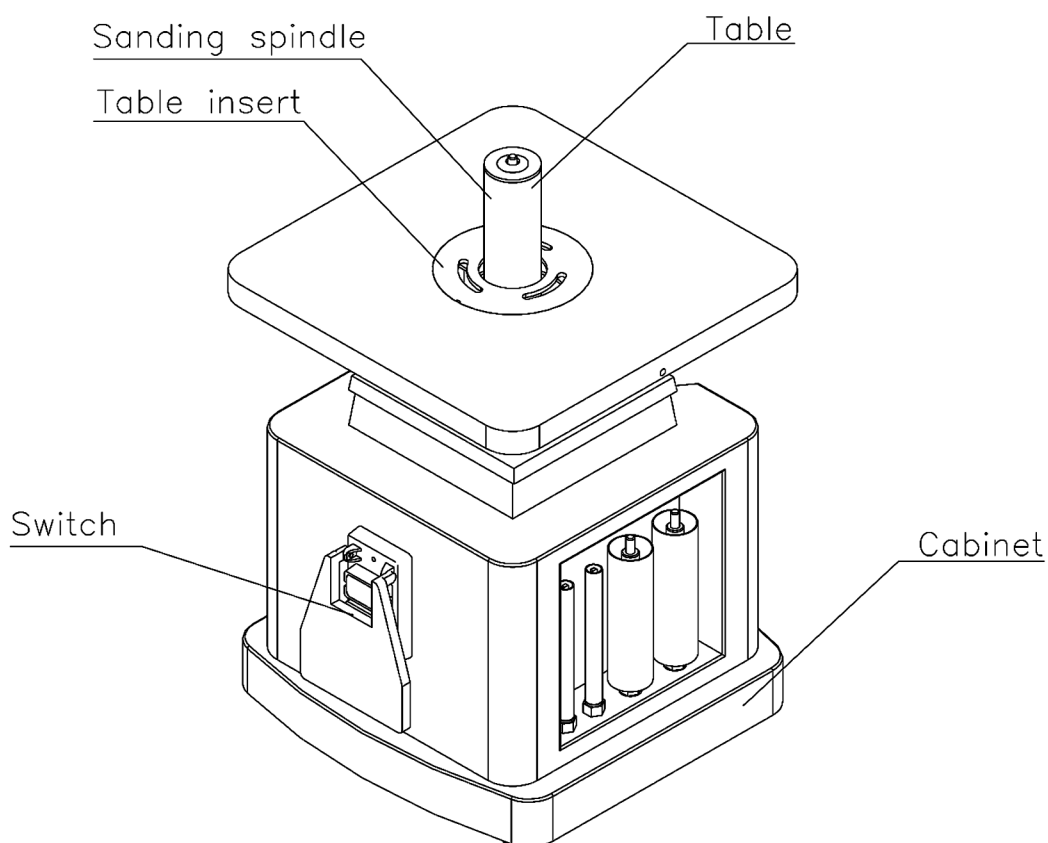

MACHINE DIMENSION

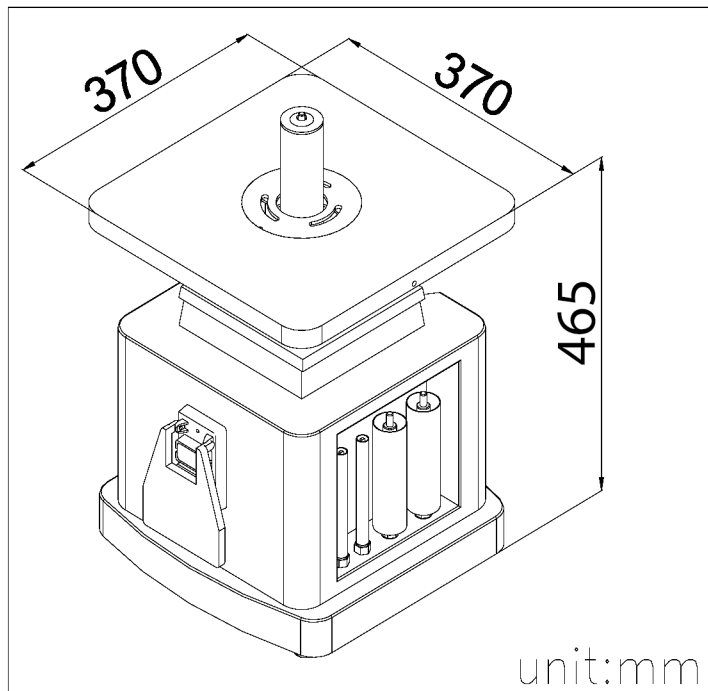

SAFE OPERATING POSITION

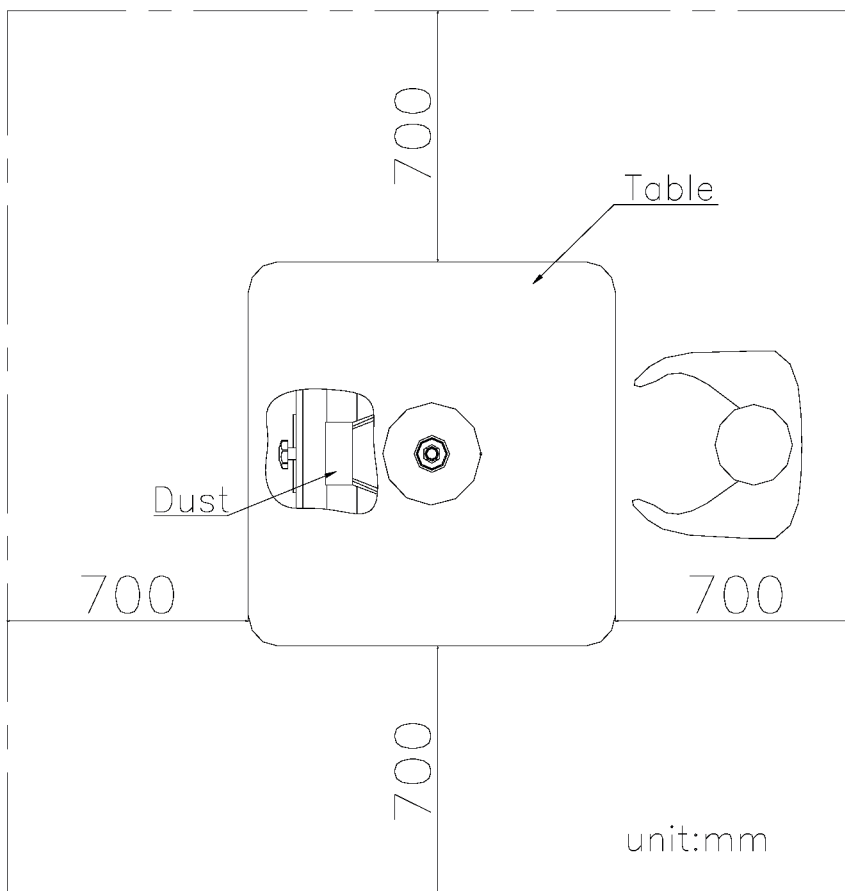

INSTRUCTIONS FOR OPERATIONS

1. Select spindle that is smaller than the curve to be sanded.
2. Use an insert plate that comes closest to the spindle without touching it.
3. Make sure that spindle is properly positioned in taper sleeve socket. With the wrench provided , tighten the nut. NOTE: Never over tighten; it may be difficult to remove the spindle later.
4. When table is set at a 90° angle, sanding may be done from any corner, or location on table around spindle.
5. When table is positioned at any angle other than 90°, it is necessary to position the work piece over the centerline, as shown on table surface.
6. Always lock the table with the hand nut when setting at any angle, also to prevent movement lock the tilting gear shaft.
7. Always loosen both table lock and tilting gear lock before changing the angle position of the table. Never force the table if it does not tilt easily, reason may be that the locks are still engaged. Never attempt to over ride the stop locks, this will cause damage to the tilting performance.
8. A backing board is recommended when sanding thin pieces of metal or any other material. A backing board can be easily constructed by using a piece of wood the length of the table, pushing it into the spindle until a half circle is formed. Clamp each end of the board to the table and proceed to sand the thin material.
9. Before leaving the machine remove any particles or pieces left over, make sure the table in 90°.

TILTING THE TABLE

1. Loosen the two table lock knobs (A), located under the table at both sides of the machine
2. Tilt the table forward to the desired angle with your hands.
3. An angle scale is provided at the right side of the trunnion to indicate the degree of table tilt.
4. Tighten the two table lock knobs securely after the table degree has been adjusted.

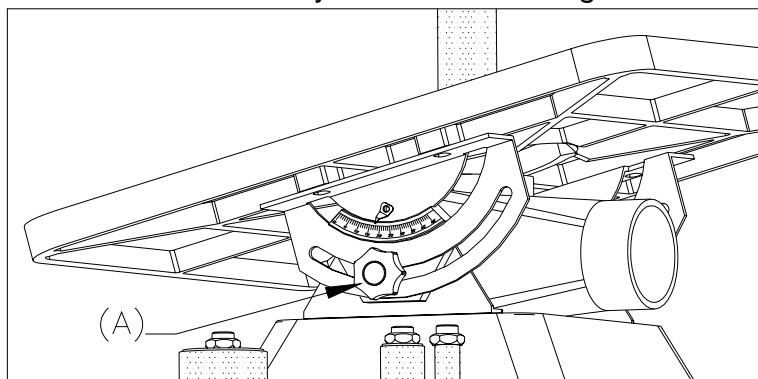

MOUNTING SPINDLE DRUM

1. Disconnect the sander from the power source.
2. Select the proper diameter of spindle drum.
3. Clean the taper part of the spindle drum before mounting it into the spindle.
4. Use an open-end wrench to lock the spindle by holding its flat surface. At the same time, use another open-end wrench to tighten the spindle drum.
5. Do not over tighten the spindle drum or it will be causing removable problem.

! WARNING!

Disconnect the power source before removing the drum.

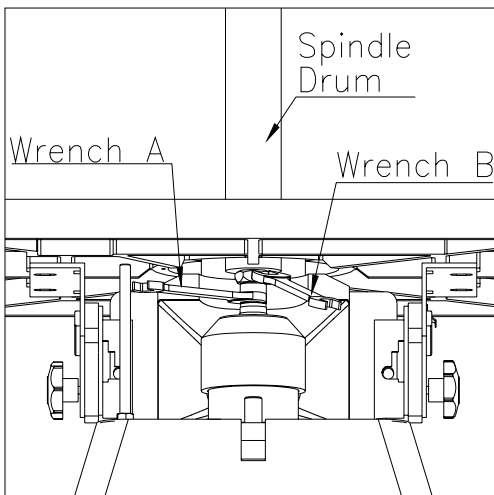

Use a wrench to lock the spindle. Use another wrench to loose the spindle drum.

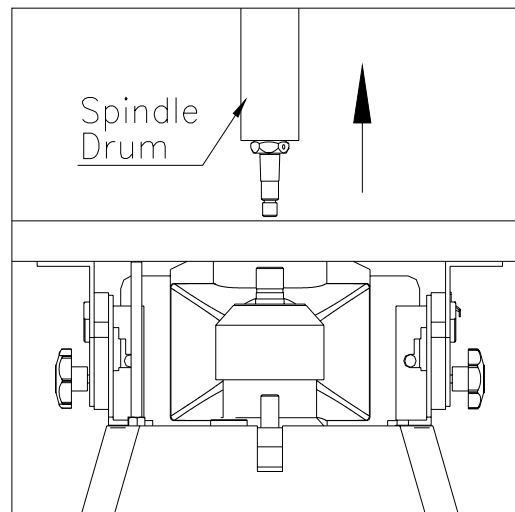

Removing an old spindle drum.

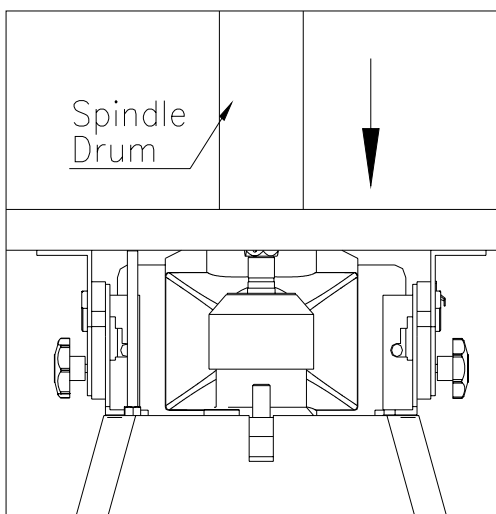

Fitting a new spindle drum.

SELECTION GUIDE FOR DRUM TO TABLE INSERT

This machine is furnished with 10 drums. The range of drum diameter is from 1/4" to 4". If the drum diameter is changed, the table insert needs to be changed to the proper size.

The table below shows which table insert to use for various drum diameters.

! WARNING!

Failure to use the correct insert with the corresponding drum may result in injury!

Drum diameter	Table insert
# 1 1/4" Dia. x 5" long	# 1
# 2 3/8" Dia. x 6" long	# 1
# 3 1/2" Dia. x 6" long	# 1
# 4 5/8" Dia. x 6" long	# 1
# 5 3/4" Dia. x 9" long	# 1
# 6 1" Dia. x 9" long	# 2
# 7 1 1/2" Dia. x 9" long	# 2
# 8 2" Dia. x 9" long	# 3
# 9 3" Dia. x 9" long	None
# 10 4" Dia. x 9" long	None

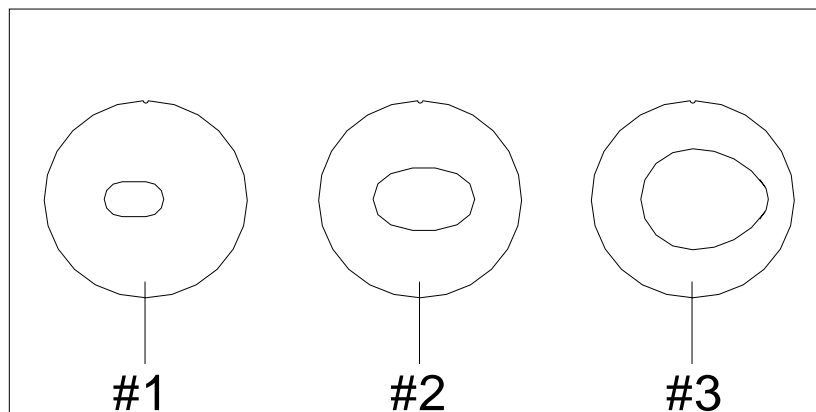

MAINTENANCE OF SPINDLE SANDER

1. To keep spindle sander in perfect condition, clean machine and attachments at all times.
2. Clean tapered sleeves and tapered socket before use, this will protect spindle sleeves from nicks.
3. Bent sleeves are easily straightened by placing them in the tapered socket and slipping a small pipe over the steel shaft. Using a dial indicator check that it is in correct position.
4. Check gearbox for proper oil level (Approx. 1/4 up on sight glass).
5. We recommend that a small amount of grease be applied to table tilting screw once a month.
6. No lubrication is required for the bearings, they are permanently lubricated.

TROUBLESHOOTING

TROUBLE	CAUSES	CORRECTION
Motor does not run when power switch is turned "ON".	<ol style="list-style-type: none"> 1. Switch is burned out. 2. Connection wire is loose or damaged. 	<ol style="list-style-type: none"> 1. Replace the switch. 2. Tighten or replace the wire.
Motor does not run at full speed.	<ol style="list-style-type: none"> 1. Power voltage is too low. 2. Motor is damaged. 	<ol style="list-style-type: none"> 1. Test voltage. 2. Check and repair motor.
Motor does not reach full power.	<ol style="list-style-type: none"> 1. Incorrect power wiring. 2. Overload. 	<ol style="list-style-type: none"> 1. Replace with the correct size power wiring. 2. Reduce sanding load.
Motor overheating	<ol style="list-style-type: none"> 1. Motor is dirty. 2. Motor is damaged. 	<ol style="list-style-type: none"> 1. Clean motor. 2. Check and repair motor.
Excessive machine vibration	Machine is incorrectly leveled.	Adjust machine leveling
Mark on workpiece	<ol style="list-style-type: none"> 1. Sanding drum is damaged. 2. Sanding cloth on drum is worn in some areas. 	<ol style="list-style-type: none"> 1. Replace the sanding drum. 2. Replace sanding cloth
Sanding drum turns in wrong direction	Wrong phase or voltage	Make sure the phase and voltage comply with machine requirement.
Burns on workpiece	Wrong abrasive grit on sanding cloth	Use coarser grit to remove more material from workpiece.

ASSEMBLY DIAGRAM

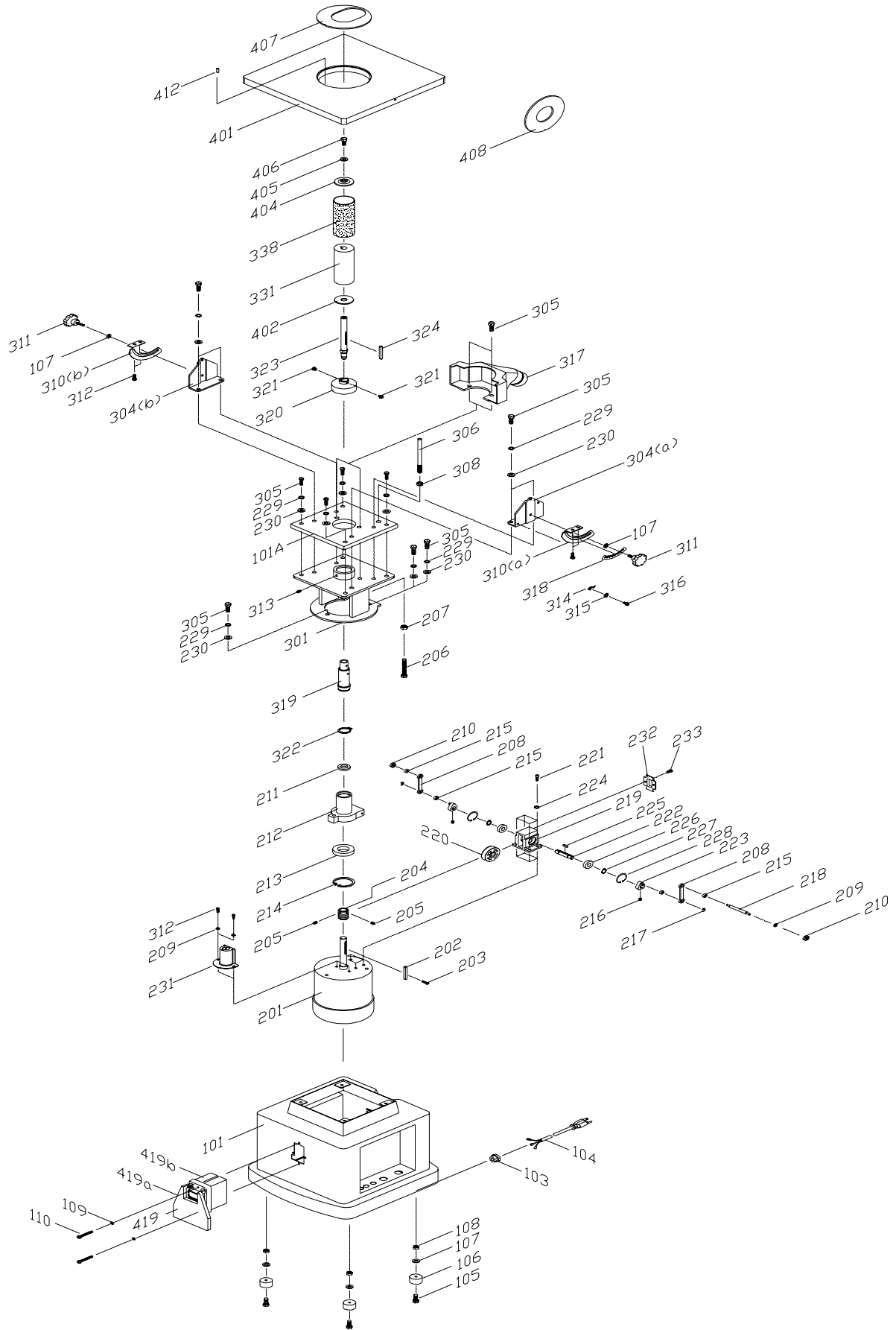

SPARE PARTS FOR OVS-TG

Key no.	Part no.	DISCRIPTION	Quantity
101	30201001G	BASE	1
101a	30201001a	TOP PLATE	1
102	W0000000	SWITCH	1
103	S1006P1	STRAIN RELIEF	1
104	L000000	POWER CORD	1
105	S0030622M	PHILIPS HEAD SCREW	4
106	10107098	RUBBER FEET	4
107	S0210403	FLAT WASHER	7
108	S0011600M	HEX. NUT	4
109	S00303040	PHILIPS HEAD SCREW	2
110	S0030318	PHILIPS HEAD SCREW	2
111	S0220300	GEAR WASHER	2
112	S0110300	HEX. NUT	4
114	30201002	SWITCH BOX	1
201	M000000	MOTOR	1
202	S0430650	KEY	1
203	S0040415M	FLAT HEAD SCREW	1
204	30202001	WORM SHAFT	1
205	S0050610M	SET SCREW	2
206	30202002	TRANSMISSION ROD	1
207	S0110800M	HEX. NUT	1
208	30202003	CONNECTING ROD	2
209	S0210303	FLAT WASHER	4
210	S0120500M	LOCKING NUT	2
211	C1106804	BEARING	1
212	30202004	TRANSMISSION	1
213	C1106006	BEARING	1
214	S0520059	C RING	1
215	30202005	BUSHING	4
216	S0050506M	SET SCREW	2
217	S05ETW04	E RING	2
218	30202020	CONNECTING SHAFT	1
219	30202006p	BRACKET	1
220	30202007p	WORM	1
221	S0010615M	HEX. SOCKET CAP SCREW	4
222	30202008P	SHAFT	1
223	30204010	CRANK SHAFT	2
224	S0230400	SPRING WASHER	4
225	S0400415	KEY	1
226	C1106001	BEARING	2
227	S0521200	C RING	2

SPARE PARTS FOR OVS-TG

Key no.	Part no.	DISCRIPTION	Quantity
228	S0530028	C RING	2
229	S0230506	SPRING WASHER	11
230	S0210500C	FLAT WASHER	11
231	30202009	OIL CAP	1
232	30202012	STORAGE PLATE FOR DRUMS	1
233	30202013	STORAGE PLATE FOR TABLE INSERTS	1
234	30202014	OIL CAP	1
235	S0030304	PHILIPS HEAD SCREW	2
301	30203001	HOUSING	1
304a	30203003	BRACKET (RIGHT)	1
304b	30203003a	BRACKET (LEFT)	1
305	S0020825M	HEX. SCREW	13
306	30203004	TOP PLATE	1
308	S0020610M	HEX. SCREW	1
310a	40501001	SUPPORT TRUNNION (RIGHT)	1
310b	40501011a	SUPPORT TRUNNION (LEFT)	1
311	S0070615M	LOCK KNOB	2
312	S0010515M	HEX. SOCKET CAP SCREW	6
313	S0050605M	SET SCREW	1
314	10102022	POINTER	1
315	S0220400	GEAR WASHER	1
316	S0030510M	PHILIPS HEAD SCREW	1
317	30203005	DUST COVER	1
319	30203006	MAIN SPINDLE	1
320	30203007	SWITCH COVER	1
321	S0030505M	PHILIPS HEAD SCREW	2
322	S0520027	C RING	1
323	30203008	5/8" SANDING SPINDLE	3
324	S0400550	KEY	1
331	30203015	2" RUBBER BUSHING	1
332	30203014	1-1/2" RUBBER BUSHING	1
334	30203017	1/2" SANDING SPINDLE	1
335	30203018	1/4" SANDING SPINDLE	1
337	30203019	1/2" CLAMP	1
338	30203021	2" SANDING SLEEVE	1
339	30203010	1/4" SANDING SLEEVE	1
340	30203011	1/2" SANDING SLEEVE	1
341	30203012	5/8" SANDING SLEEVE	1
342	30203013	1-1/2" SANDING SLEEVE	1
344	30203019a	5/8" CLAMP	1

SPARE PARTS FOR OVS-TG

Key no.	Part no.	DISCRIPTION	Quantity
345	30203019b	1/4" CLAMP	1
401	30204001	TABLE	1
402	20301002	2" LOWER FOLLOWER PLATE	2
403	20801002	1-1/2" UPPER FOLLOWER PLATE	1
404	20301044	2" UPPER FOLLOWER PLATE	1
405	S0210500	FLAT WASHER	1
406	S0110500L	HEX. NUT	1
407	30204003	2" TABLE INSERT (OVAL)	1
408	30204004	2" TABLE INSERT (ROUND)	1
409	30204005	3/4" TABLE INSERT (ROUND)	1
410	30204006	3/4" TABLE INSERT (OVAL)	1
412	S0310312	SPRING PIN	1
413	30201003	WRENCH	1
414	10105091	WRENCH	1

The Axminster guarantee

Buy with confidence from Axminster!

So sure are we of the quality, we cover all parts and labour free of charge for three years!



For more information visit [axminstertools.com/3years](https://www.axminstertools.com/3years)



The packaging is suitable for recycling.
Please dispose of it in a responsible manner.



EU Countries Only

Do not dispose of electric tools together with household waste material.
By law they must be collected and recycled separately.



Axminster Tools, Axminster Devon EX13 5PH
[axminstertools.com](https://www.axminstertools.com)