

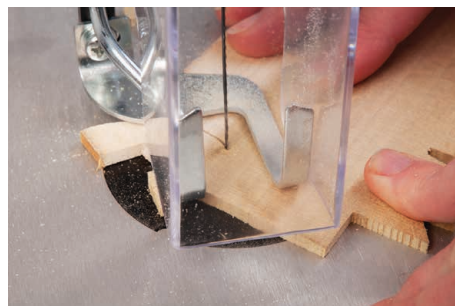

AW405SS

Scroll Saw

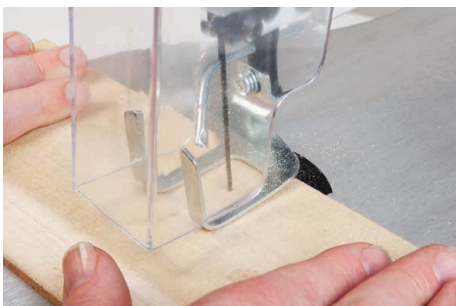

INDEX OF CONTENTS

What's Included	03
General Note	03
Introduction	04
General Safety Instructions for 230V Machines	04
Specific Safety Precautions for Scroll Saws	05
Specification	05
Assembly	06
Mounting the Scroll Saw	07
Illustration and Parts Description	08-09
Setup and Adjustment	10-11
Operating Instructions	12-13
Changing the Blade	14-15-16
Maintenance	17-18
Troubleshooting	19
Exploded Diagrams/Lists	20-21
Wiring Diagram	22
Declaration of Conformity	23-24

The symbols below advise the correct safety procedures when using this machine.

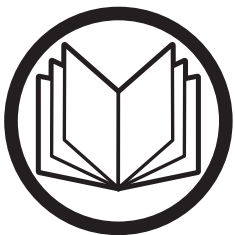

Fully read manual
and safety instructions
before use



Ear protection
should be worn



Eye protection
should be worn



Dust mask
should be worn



HAZARD

WHAT'S INCLUDED

Quantity	Item	Part	Model Number
			AW405SS
1	405mm Scroll Saw	A	
1	Blade Guard	B	
1	Pinless Blade	C	
1	'T' Handle Hex Key	D	
1	Instruction Manual		



GENERAL NOTE

Please read the Instruction Manual prior to using your new tool; as well as the operating procedures for your new tool, there are numerous hints and tips to help you to use the tool safely and to maintain its efficiency and prolong its life. There is

also a detailed description of the parts of your scroll saw, which will enable you to become familiar with terminology we will use in this manual. Keep this Instruction Manual readily accessible for any others who may also be required to use the tool.

INTRODUCTION

The AC405SS variable speed (550-1,600/min) scroll saw comes with a powerful DC motor and can easily cope with cutting a wide variety of materials up to 50mm deep. The two blade arms are independently pivoted giving a virtually straight up-and-down motion to the blade for a better quality cut.

A 35mm diameter dust port allows the scroll saw to be connected to a vacuum cleaner. A generous table (410 x

254mm) with a 406mm (16") throat, tilts to 45° for bevel cutting. The saw accepts pinned or plain end blades. The clamps are easily accessible for blade changing. A blower helps keep the cutting line clean and easily seen. When changing blades a quick release tension knob allows quick and easy change. The heavy cast iron base gives stability and ensures low vibration.

GENERAL SAFETY INSTRUCTIONS FOR 230V MACHINES

The following will enable you to observe good working practices, keep yourself and fellow workers safe and maintain your tools and equipment in good working order.



WARNING!! KEEP TOOLS AND EQUIPMENT OUT OF REACH OF YOUNG CHILDREN



KEEP WORK AREA AS UNCLUTTERED AS IS PRACTICAL. UNDER NO CIRCUMSTANCES SHOULD CHILDREN BE ALLOWED IN WORK AREAS.

Mains Powered Tools

- Tools are supplied with an attached 13 Amp UK 3 pin plug, fitted with 5 amp fuse.
- Inspect the cable and plug to ensure that neither are damaged. Repair if necessary by a suitably qualified person.
- Do not use when or where it is liable to get wet.

Workplace

- Do not use 230V a.c. powered tools anywhere within a site area that is flooded.
- Keep machine clean.
- Leave machine unplugged until work is about to commence.
- Always disconnect by pulling on the plug body and not the cable.

- Carry out a final check e.g. check the cutting tool is securely tightened in the machine and the correct speed and function set.
- Ensure you are comfortable before you start work, balanced, not reaching etc.
- Wear appropriate safety clothing, goggles, gloves, masks etc. Wear ear defenders at all times.
- If you have long hair wear a hair net or helmet to prevent it being caught up in the rotating parts of the machine.
- Consideration should be given to the removal of rings and wristwatches.
- Consideration should also be given to non-slip footwear etc.
- If another person is to use the machine, ensure they are suitably qualified to use it.
- Do not use the machine if you are tired or distracted
- Do not use this machine within the designated safety areas of flammable liquid stores or in areas where there may be volatile gases.
- Check cutters are correct type and size, are undamaged and are kept clean and sharp, this will maintain their operating performance and lessen the loading on the machine.
- **OBSERVE....** make sure you know what is happening around you and **USE YOUR COMMON SENSE.**

SPECIFIC SAFETY PRECAUTIONS FOR SCROLL SAWS

1. Wear safety goggles as protection against flying wood chips and saw dust. In many cases, a full face shield is even better protection. A dust mask is also recommended to keep saw dust out of your lungs.
2. The scroll saw must be bolted securely to a stand or work bench. If the saw has a tendency to move during certain operations, bolt the stand or workbench to the floor.
3. A solid wood workbench is stronger and more stable than a workbench with a plywood table.
4. This scroll saw is for indoor use only.
5. Do not cut pieces of material which are too small to be held by hand.
6. Clear the work table of all objects except the work piece (tools, scraps, rulers etc.) before turning the saw on.
7. Make sure the blades' teeth are pointing down, toward the table, and that the blade tension is correct.
8. When cutting a large piece of material, support it at the height of the table.
9. Do not feed the work piece through the blade too fast. Feed only as fast as the blade will cut.
10. Keep your fingers away from the blade. Use a push stick as you near the end of the cut.
11. Take care when cutting a work piece which is irregular in cross section. Moulding for example must lie flat, and not 'rock' on the table as it is being cut. A suitable support must be used.
12. Take care when backing off a work piece from the blade, as the blade may bind in the kerf. In this event, switch OFF the machine and disconnect from the supply. Wedge open the kerf and withdraw the work piece.
13. Switch off the saw, and make sure the blade has come to a complete stop before clearing sawdust or off-cuts from the table.
14. Make sure there are no nails or foreign objects in the part of the work piece to be sawn.
15. Be extra cautious with very large or small, or irregularly shaped work pieces.
16. Set up the machine and make all adjustments with the power OFF, and disconnected from the supply.
17. DO NOT operate the machine with the covers off. They must all be in place and securely fastened when performing any operation.
18. Be sure to use the correct blade size and type.
19. Use ONLY approved replacement saw blades. Contact your local Axminster Tool Centre for advice. The use of inferior blades may increase the risk of injury.

SPECIFICATION

Code	107678
Model	AC405SS
Rating	Home Workshop
Power	125W DC Motor 230V 50Hz 1Ph
Duty Cycle	S1 70W
Throat Depth	406 mm
Stroke	15 mm
Cutting Depth @ 90°	50 mm
@ 45°	20 mm
Cuts per Minute	550-1,600
Table Size	410 x 254 mm
Table Tilt	0° - 45°
Dust Extraction Outlet	35 mm
Overall Lx W x H	630 x 290 x 350 mm
Weight	11.5 kg

ASSEMBLY

Having unpacked your scroll saw and its accessories please dispose of any unwanted packaging properly. The cardboard packaging is biodegradable.



PLEASE DISPOSE OF ANY UNWANTED PACKAGING PROPERLY. THE POLYTHENE, POLYSTYRENE AND CARD IS RECYCLABLE.

Your scroll saw is fully assembled, except for the Blade Guard assembly (B) and the hose for the blower. Please follow the instruction below.



DON'T OVERTIGHTEN AS THE GUARD IS ONLY PLASTIC!

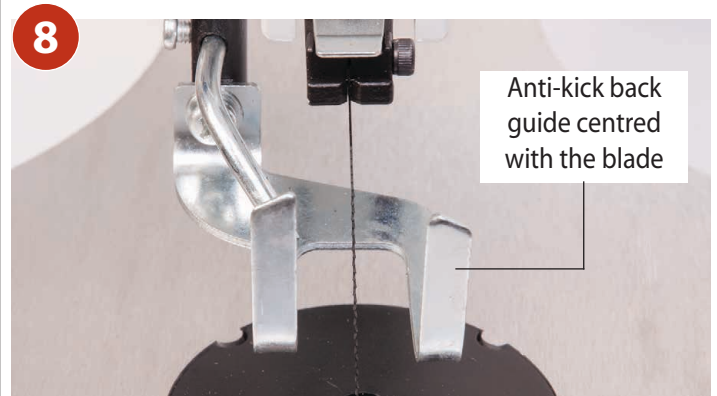

MOUNTING THE SCROLL SAW

It is strongly recommended that you mount the machine to a workbench or to a purpose built scroll saw stand. A pad between the saw and the workbench/stand is also recommended to reduce vibration. Ensure you use flat washers between the bolt head and mounting holes, see figs 01-02-03.

NOTE: Fretsaw Stand Only. You may need to add a larger sub-table (MDF or Plywood plate) to give extra support to larger models.

Fig 01-02-03

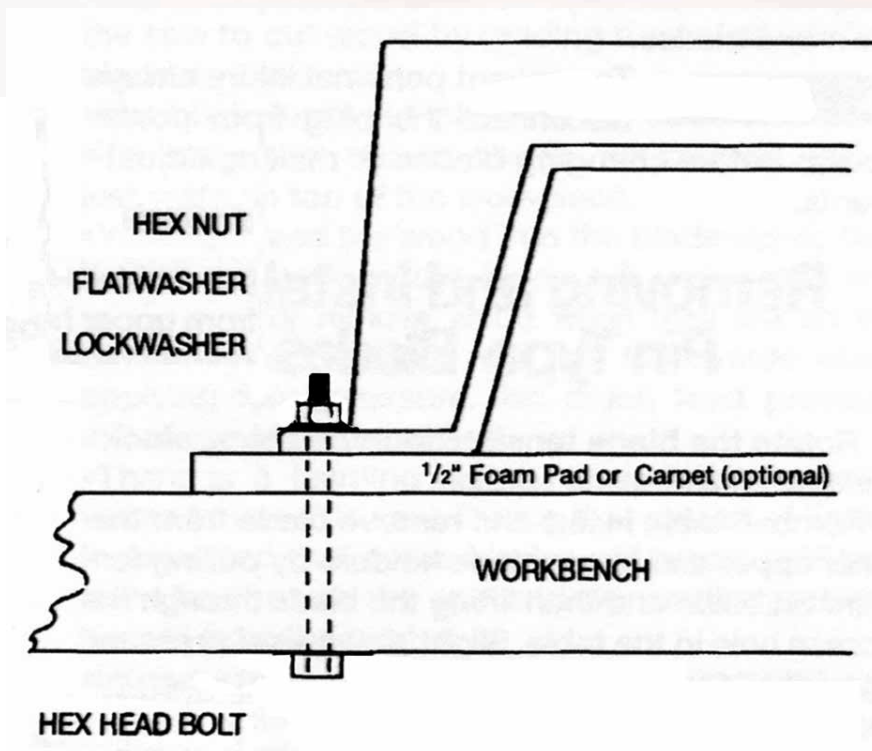
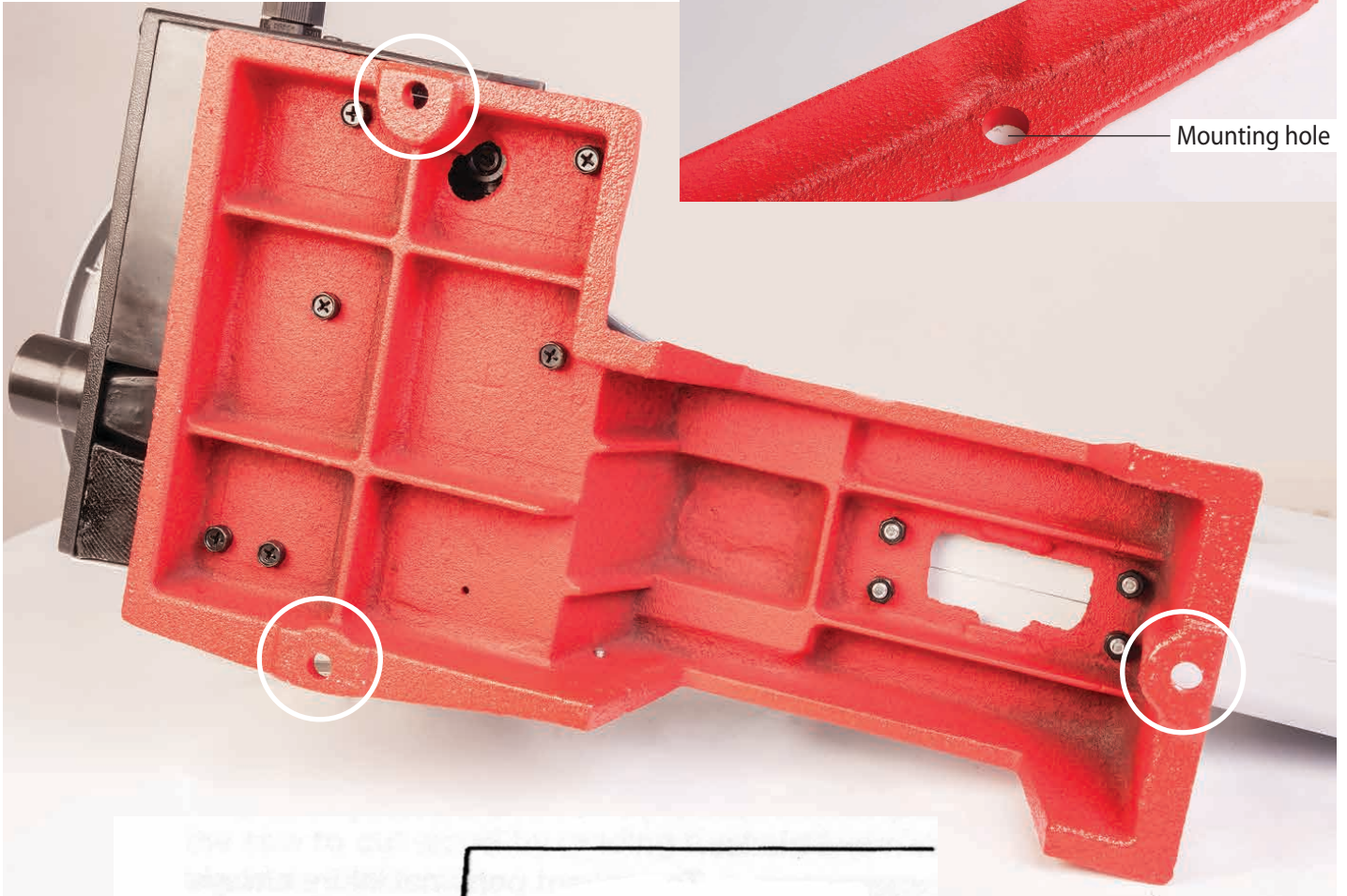

ILLUSTRATION AND PARTS DESCRIPTION

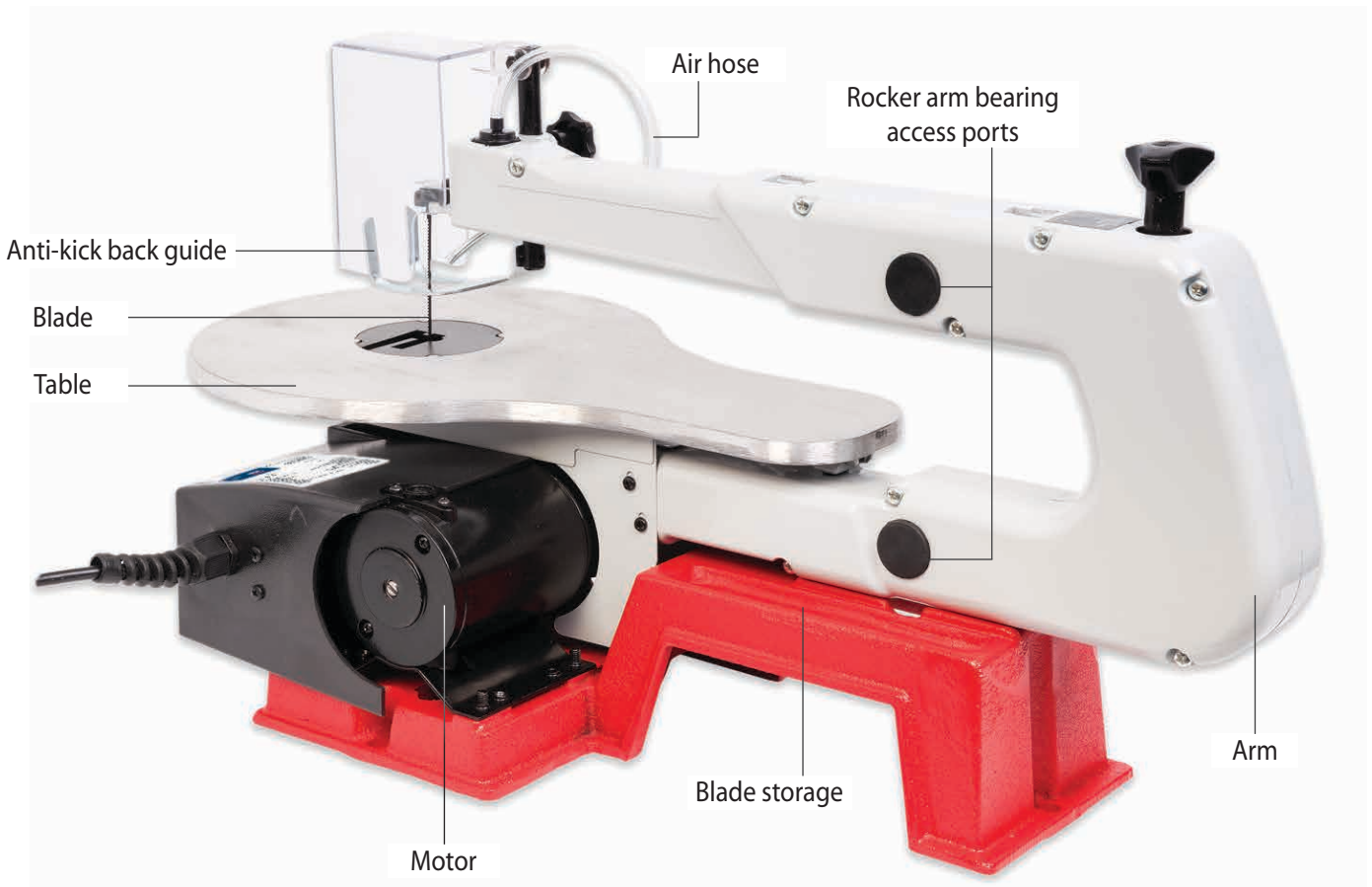
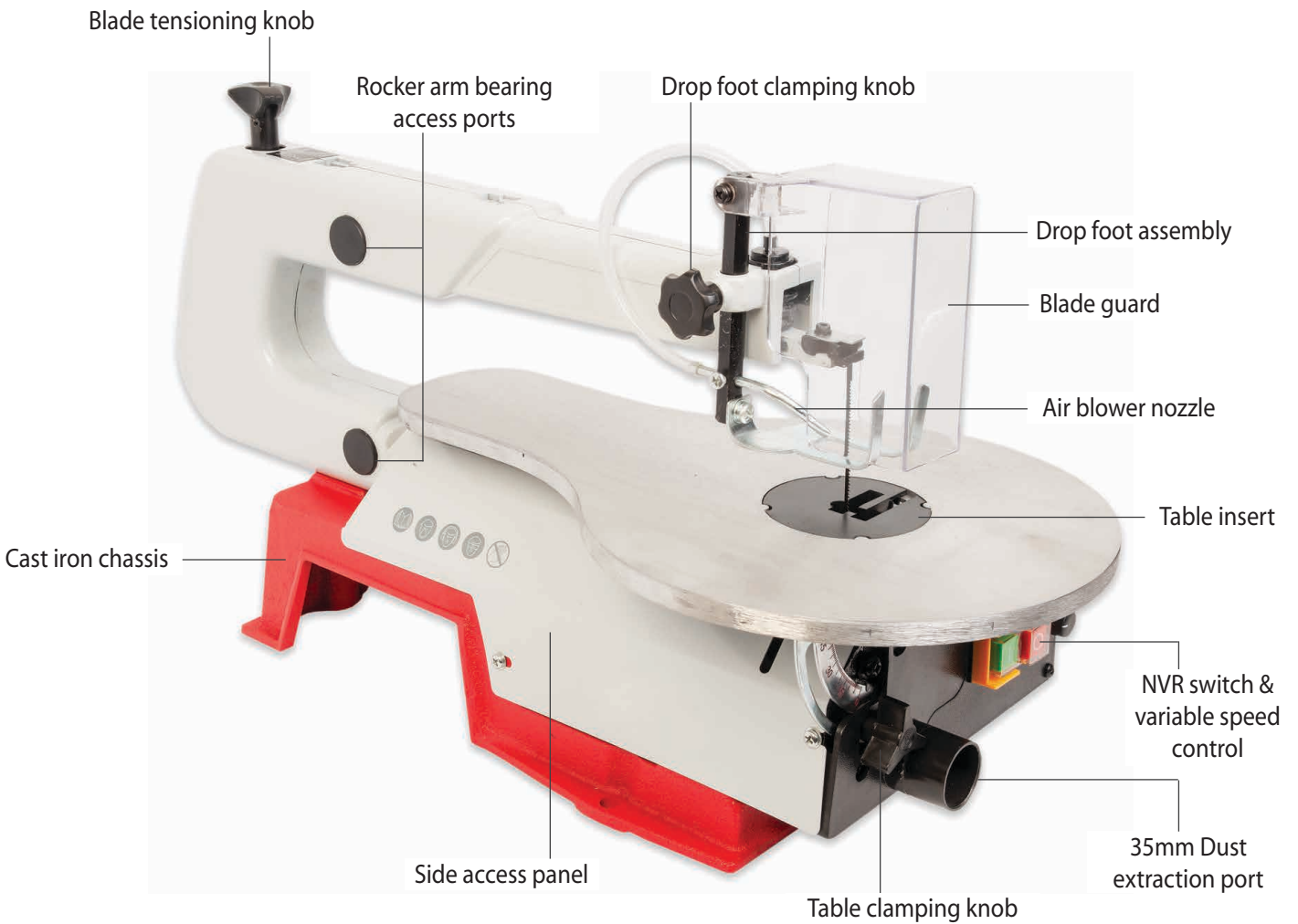
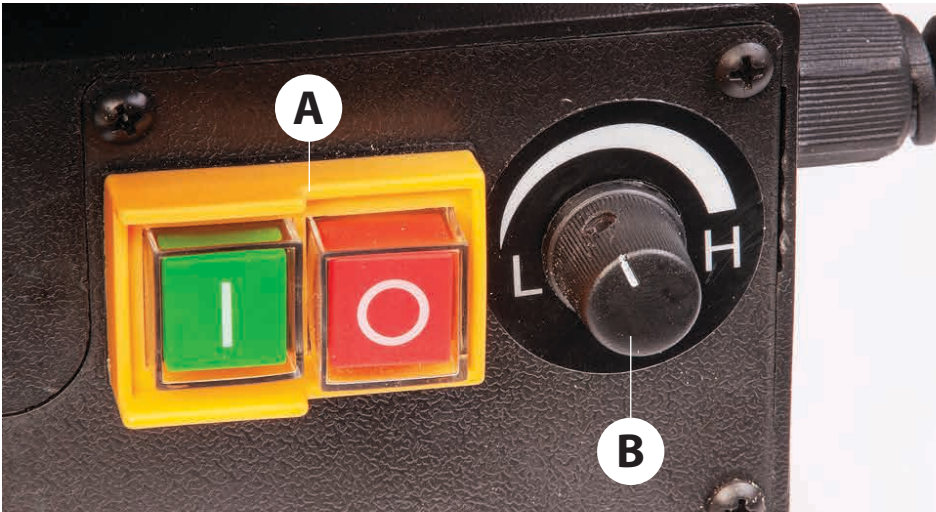
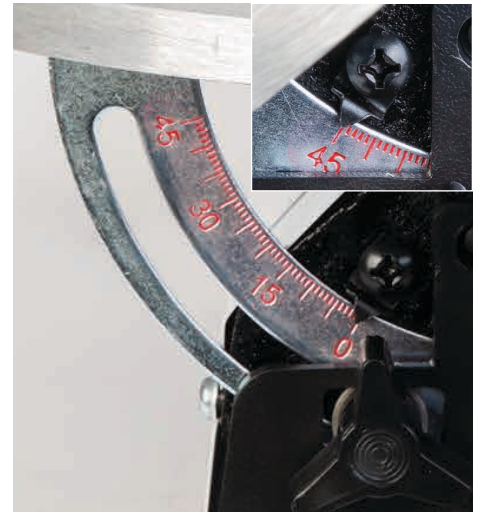

ILLUSTRATION AND PARTS DESCRIPTION



NVR ON/OFF switch (A), Variable speed control (B)



0-45° Degrees scale & pointer

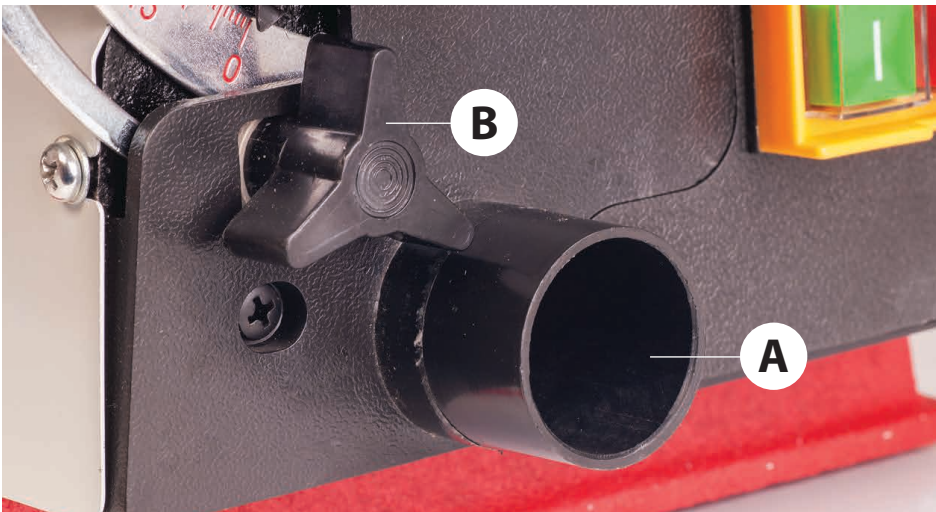

35mm dust extraction port (A), Table clamping star knob (B)



Blade tensioning knob



Air pump bellows

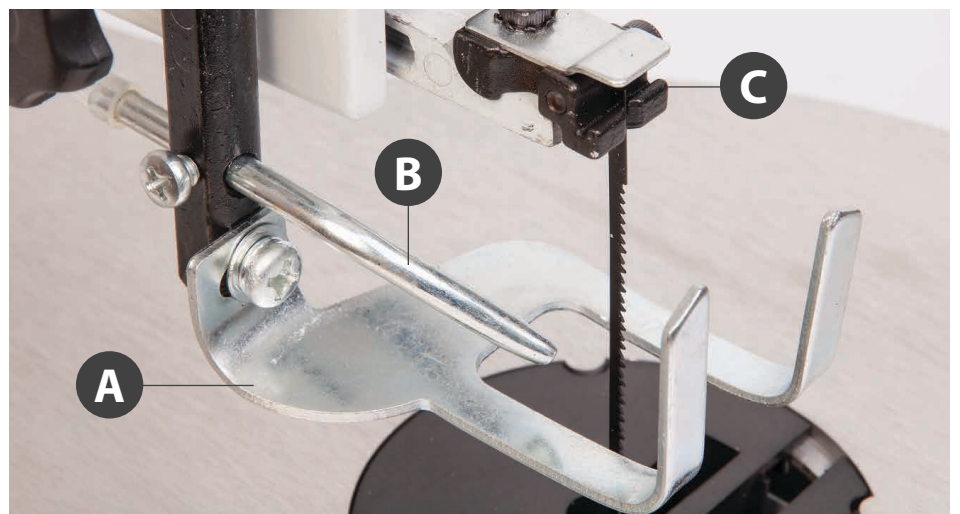

Anti-kick back guide (A), Air blower nozzle (B), Upper blade holder cradle assembly (C)

SETUP AND ADJUSTMENT

The scroll saw comes with the blade assembled. Please follow the instruction below on how to tension your saw.

Tensioning the Blade

Check that the blade is under tension. If the blade is loose, turn the blade tensioning knob to the rear of the arm to take up the slack then turn the knob one full turn clockwise. Check that the blade is sufficiently tensioned by pinging the blade, see fig 05-06.

NOTE: Before turning the knob one full turn, place a positioning mark on the knob to make sure you don't over tension the blade, see fig 04.



WARNING! DO NOT OVERTIGHTEN THE BLADE OTHERWISE THE BLADE WILL BREAK.

Fig 04-05-06



Setting the Table

1. Place an engineer's square on the table and position it up-against the blade, making sure that the square is not in contact with any of the teeth. Check that the blade is perpendicular (90°) to the table, see fig 07.
2. If adjustment is required, loosen the table clamping knob and rotate the table until correct. Re-tighten the knob to secure the table, see fig 08.
3. Check that the scale pointer is pointing at ZERO degrees on the scale. If not, loosen the Phillips screw and adjust pointer until correct, re-tighten the screw, see fig 09.

Fig 07-08-09

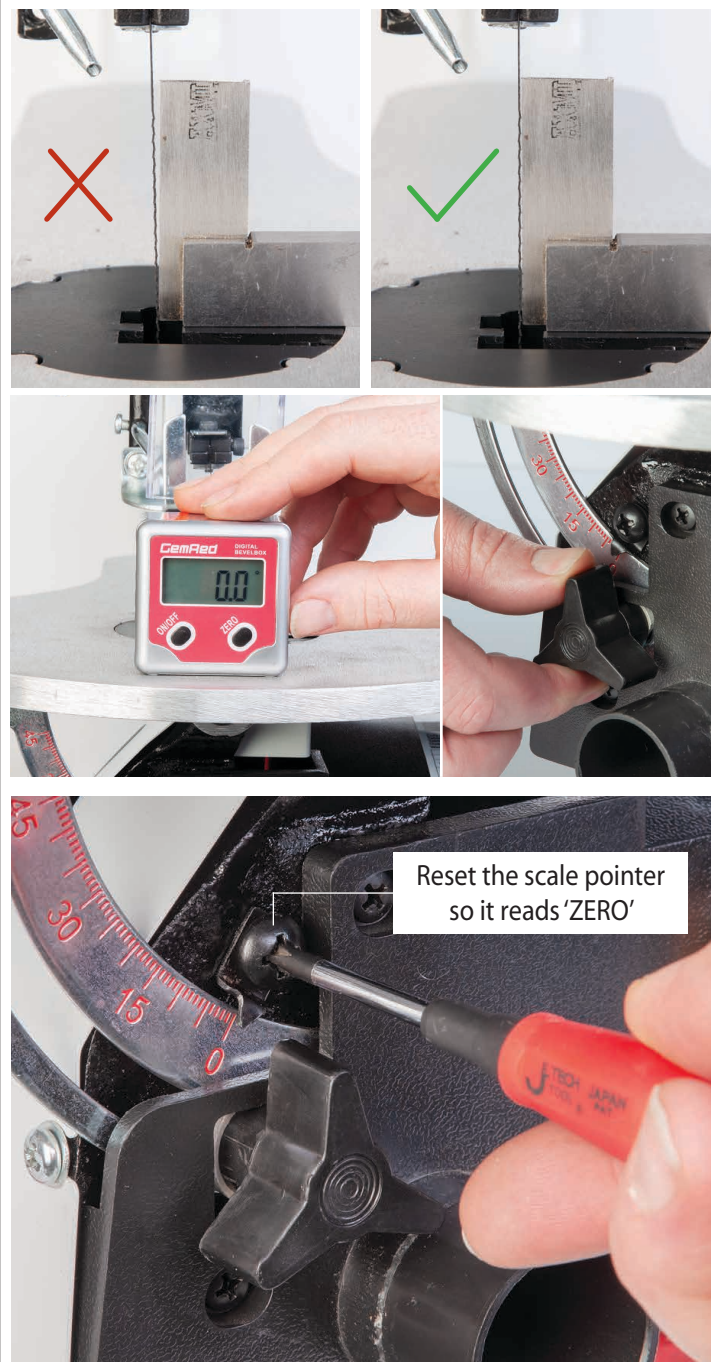

Setting the Anti-kick back guide

Place your work on top of the work table and lower the anti-kick back guide by loosening the drop foot clamping knob. Position the anti-kick back guide, so its just above your work piece, clamp the drop foot assembly in position, see fig 10-11.

Fig 10-11



Setting the Air Blower Nozzle

Loosen the screw (A) holding the air blower nozzle and adjust so its pointing towards the front of the blade, see fig 12-13.

Fig 12-13

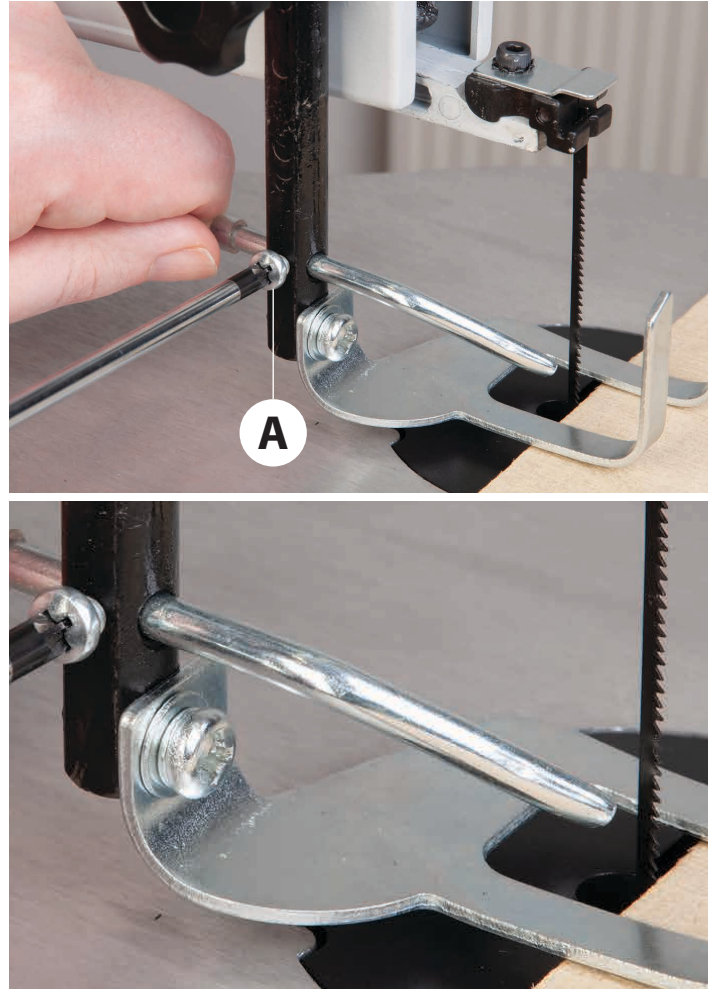

OPERATING INSTRUCTIONS

NOTE: If you are new to scroll saws, there will be a learning period, a period to learn the saw itself, and a period to learn how the wood and saw work together.

Expect some blade breakages, scroll saw blades are fairly fragile, compared to blades found on a bandsaw.



UNDER NO CIRCUMSTANCES SHOULD CHILDREN BE ALLOWED IN THE WORK AREA AND KEEP TOOLS AND EQUIPMENT OUT OF REACH OF YOUNG CHILDREN!



CHECK THAT EVERYTHING IS SECURE, THAT THE BLADE IS TIGHT AND ALL NON ESSENTIAL ITEMS HAVE BEEN CLEARED AWAY FROM THE WORK AREA. CONNECT A DUST EXTRACTION UNIT TO THE DUST EXTRACTION OUTLET ON THE SCROLL SAW.



SEE THE SYMBOLS ON PAGE TWO FOR WEARING THE CORRECT SAFETY PROTECTION WHEN USING THIS MACHINE.



CONNECT A DUST EXTRACTION MACHINE TO THE SAW.



CONNECT THE SCROLL SAW TO THE MAINS SUPPLY AND SWITCH ON.

1. Before turning on the scroll saw make sure the variable speed control is turned down low, see fig 14. Place the work piece on the table and lower the guard so its just above the work piece.

OPERATING INSTRUCTIONS

Fig 14-15

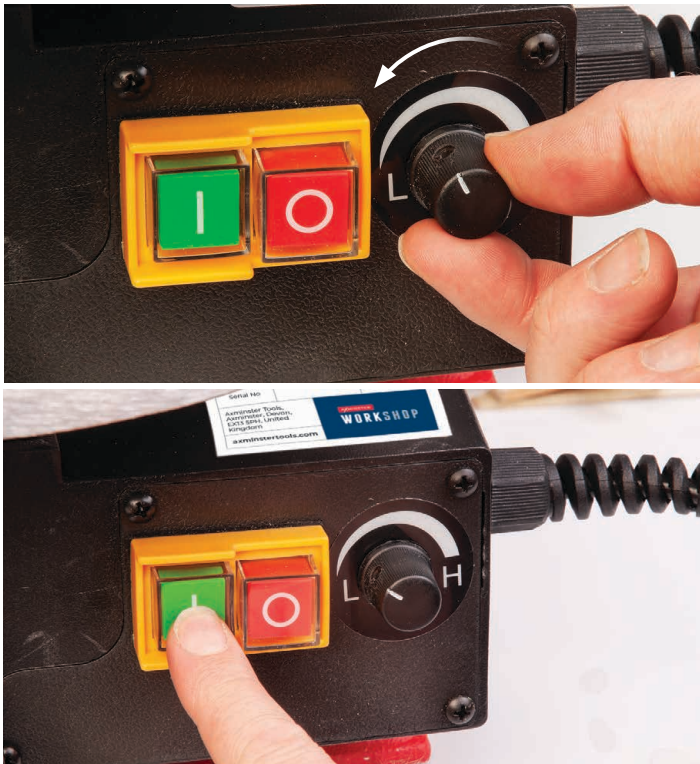

2. Switch on the scroll saw by pressing the 'GREEN ON' button, see fig 15. Adjust variable speed so its a between 'Low and High', supporting the work piece with both hands slowly guide the work piece forward into the blade, see fig 16.

Fig 16



NOTE: You must guide the wood into the blade **SLOWLY**, because the teeth are very small, and it cuts **ONLY** on the downward stroke. If you push the wood into the blade too rapidly, you can easily break the blade.

NOTE: If you find the blade is struggling to cut through, increase the speed by turning the variable speed knob.

3. Once you have completed your cut, switch off the scroll saw by pressing the red 'OFF' button.



DISCONNECT THE SCROLL SAW FROM THE MAINS SUPPLY!

Fig 17



4. If you have finished using the scroll saw, clean above and below the work table and wipe the scroll saw over, see fig 17.

5. If the scroll saw is not going to be used for a period of time, use 'Ambersil Dry PTFE Film Antistick', spray, code 952137 over the work table to prevent the table from rusting and place a dust sheet over the scroll saw.



Tilting the table to 45°

1. Loosen the table's butterfly clamp and rotate the table to +/- 45° degrees and re-tighten clamp, see fig 18-19.

Fig 18-19





CONNECT THE SCROLL SAW TO THE MAINS SUPPLY!

- Place the work piece on the table and set the guard so it's just above the work piece.
- Switch on the scroll saw by pressing the green 'ON' button, set the variable speed and carefully guide the work piece into the blade, see fig 20.
- Once you have completed your cut, switch off the scroll saw by pressing the red 'OFF' button.



DISCONNECT THE SCROLL SAW FROM THE MAINS SUPPLY!

Fig 20



Scroll Saw Operating Characteristics

The scroll saw's unique ability is cutting intricate curves which other saws cannot do. A scroll saw can also be used for straight line cutting such as cross cuts, ripping and bevels. The following is a list of points to remember when using a scroll saw.

- The saw does not cut wood by itself. You feed the work piece into the blade, letting the blade cut the wood as you move the piece ahead.
- You must guide the wood into the blade **SLOWLY**, because the teeth are very small, and cut **ONLY** on the down stroke. If you push the wood into the blade too rapidly, you can easily break the blade.
- Although the capacity of the saw accepts wood up to 2" (50mm) thick, better results are obtained with wood no more than 1" (25mm) thick. For wood thicker than 1", you must guide the wood into the blade very slowly, taking care not to bend or twist the blade.

4. The teeth on the blade will wear out sooner or later. The blade must therefore be replaced often to obtain the best cutting results. A blade will stay sharp for half an hour to 2 hours of continuous running, depending on the material being cut.

5. Be aware that the blade has a tendency to follow the grain of the wood. You can compensate for this by watching the grain carefully and guiding the wood past the saw blade.

6. If you are not familiar with scroll saws, there will naturally be a learning period - a period to learn the saw itself, and a period to learn how the wood and saw work together. Expect some blade breakages, scroll saw blades are fairly fragile not the same types of blade you find on a handsaw or circular saw.

Cutting Intricate Patterns

One capability a scroll saw has that other saws do not, is cutting intricate patterns inside a work piece. To do this, you should adopt the following procedure.

- Drill a 1/4" hole in the middle of the work piece, in an area which will not be a part of the finished object.



DISCONNECT THE SCROLL SAW FROM THE MAINS SUPPLY!

- Switch off and unplug the machine from the supply.
- Remove the blade from the machine, see pages 14-15.
- Place the work piece on the table, with the 1/4" hole over the access hole in the table.
- Replace the blade, through the hole in the work piece, (with the teeth pointing downwards), and re-tension the blade.

NOTE: To get better access to the lower blade holder, remove the side access panel.

Check to ensure that the work piece is not touching the blade before switching ON.



CONNECT THE SCROLL SAW TO THE MAINS SUPPLY!

- Switch on the saw and continue with operation.

CHANGING THE BLADE

Standard Pin Blades



DISCONNECT THE SCROLL SAW FROM THE MAINS BEFORE CONTINUING!

1. Turn the blade tensioning knob anti-clockwise to release tension on the blade and remove the table insert, see fig 21-22.

Fig 21-22



2. Beneath the table there is an elongated access slot machined into the side access panel, see fig 23. Using the supplied handle Hex key (D) insert the key through the slot and loosen the lower blade holder caphead screw, see fig 24-25.

Fig 23-24-25

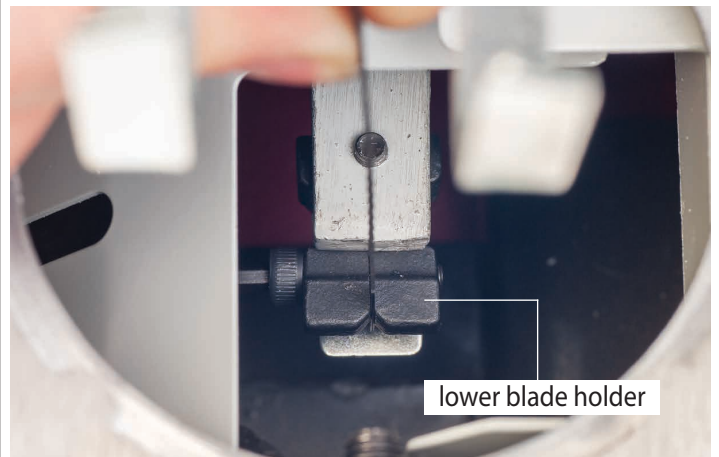
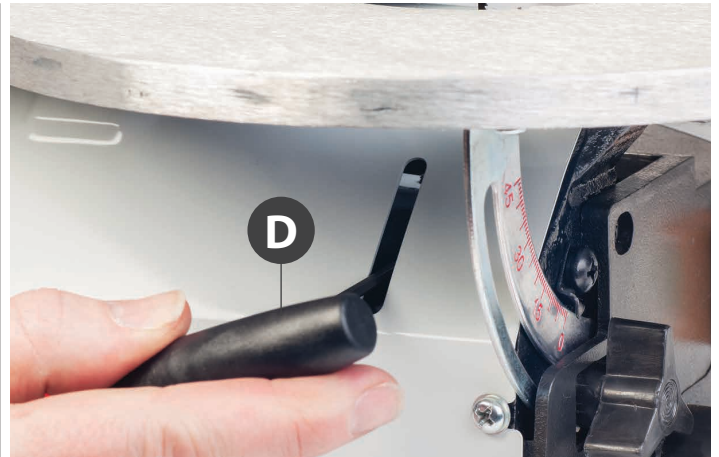
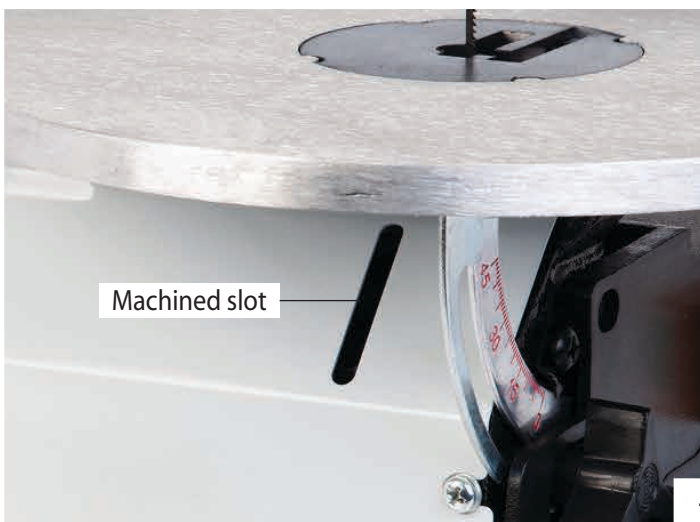

3. Repeat for the upper blade holder, see fig 26 and remove the blade, see fig 27.

NOTE: The blade can be removed from the lower blade holder without removing the side access panel but figure 28 shows a detail picture for clarity.

Fig 26-27-28

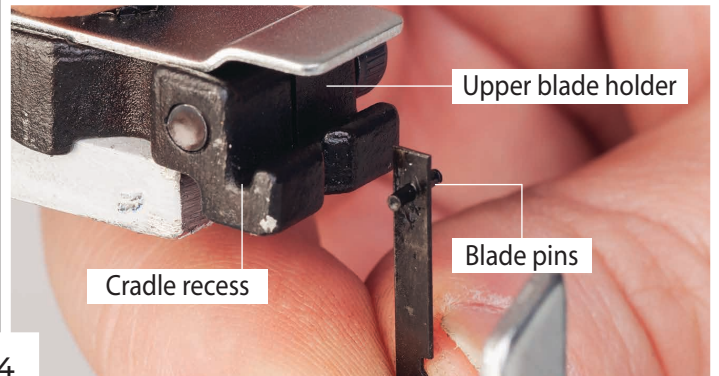
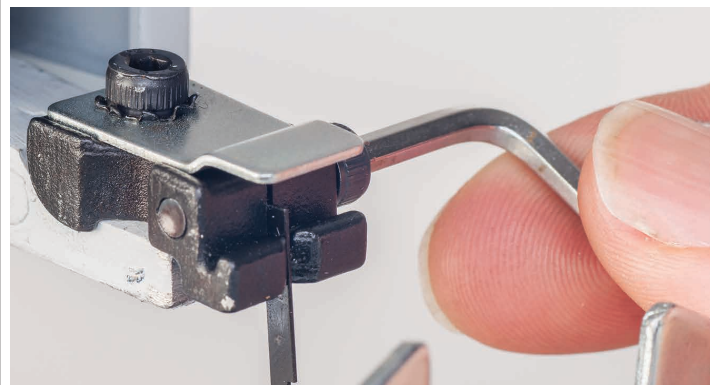

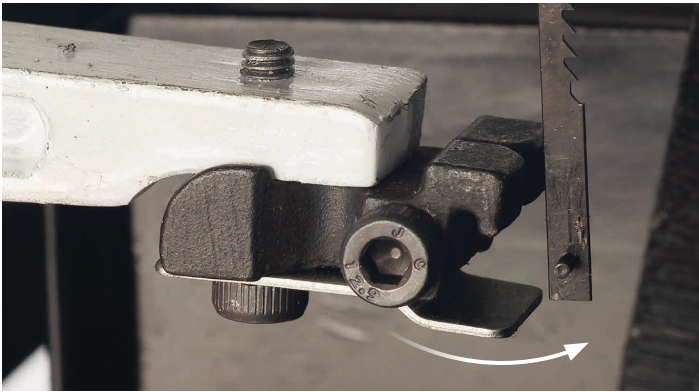

4. Clean both blade holders and remove any compacted crud before fitting a new blade.

5. Check sawblade for flaws (cracks, broken teeth, bending) before installation.



WARNING! DO NOT USE FAULTY SAWBLADES.



MAKE SURE THE TEETH ARE POINTING IN THE CUTTING DOWN DIRECTION!

6. Lower the pinned blade down through the table insert hole and into the lower blade holder housing. Insert the blade between the slot in the holder so that the pins on the end of the blade engage into the cradle's recess. Repeat for the upper blade holder, see fig 29-30.

Fig 29-30-31

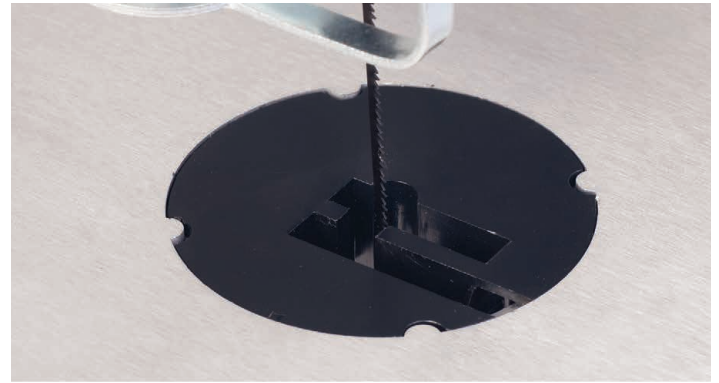
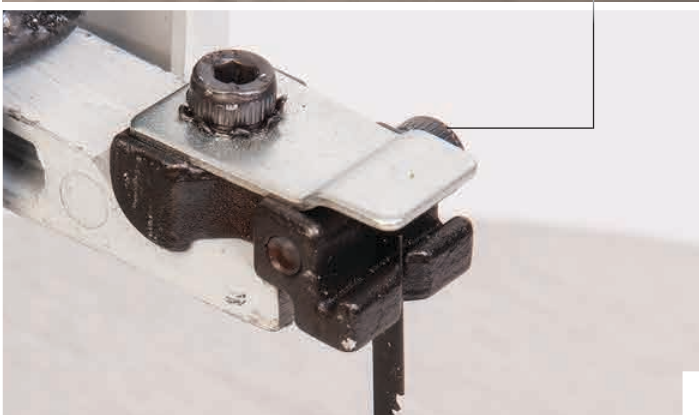
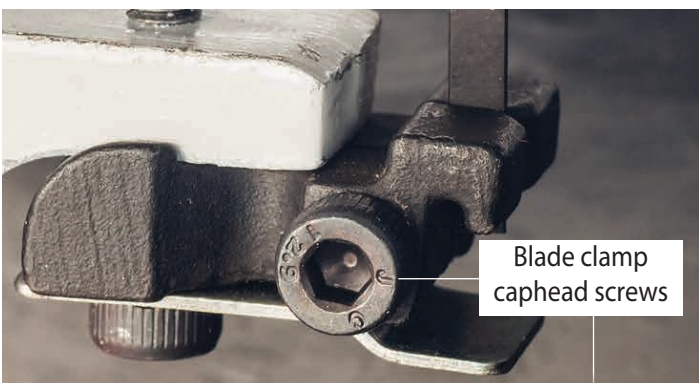

7. Make sure that the pins are seated correctly in both cradles and nip up both blade holder caphead screws. Replace the table insert, see fig 31 and re-tension the blade as described on page 10.



CLEAR AWAY ANY TOOLS AROUND THE WORK AREA.



CONNECT THE SCROLL SAW TO THE MAINS SUPPLY!

8. Start the scroll saw and check everything running correctly. If all OK, switch off the saw. If not repeat steps 1-7.

Pinless Blades



DISCONNECT THE SCROLL SAW FROM THE MAINS SUPPLY!

The scroll saw will accept pinless blades, to fit follow the instruction below.

1. Repeat steps 1-4 on the previous page to remove the standard pinned blade and clean both blade holders.

2. Check pinless sawblade for flaws (cracks, broken teeth, bending) before installation. Lower the blade down through the table insert hole and into the lower housing. Insert the blade between the slot in the upper blade holder, see fig 32 and re-tighten the caphead screw to secure the blade in position. Repeat for the lower blade holder, see fig 33.

Fig 32-33

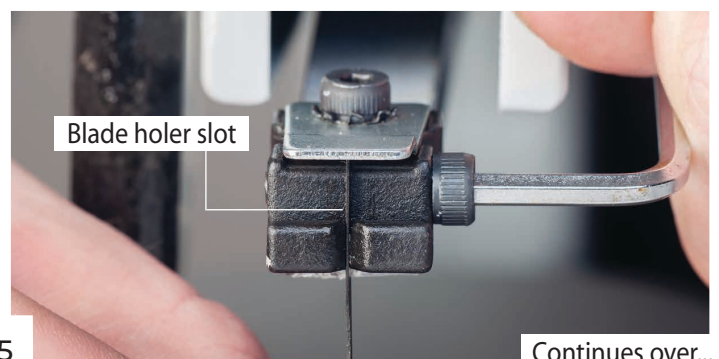

CHANGING THE BLADE

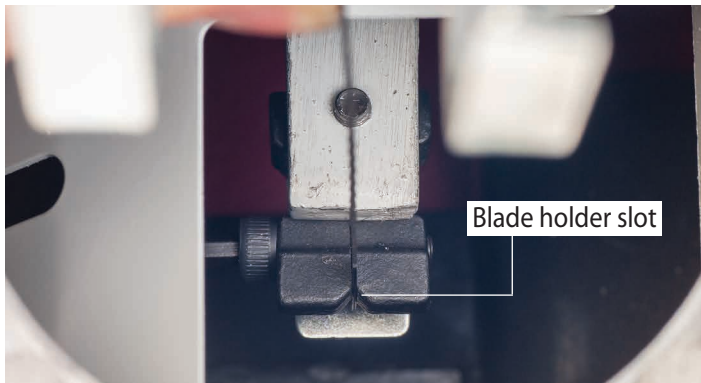

3. Place a 90° degrees square behind the blade and check its perpendicular with the table. If adjustment is required adjust the pinless blade until correct.

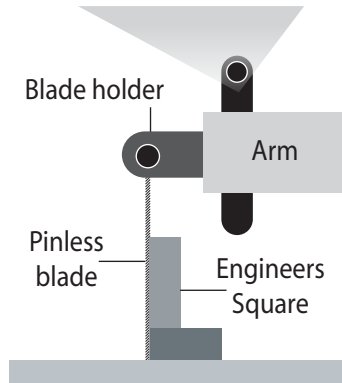

NOTE: You may need to remove the anti-kick back guide to gain access



CLEAR AWAY ANY TOOLS AROUND THE WORK AREA.



CONNECT THE SCROLL SAW TO THE MAINS SUPPLY!

4. Start the scroll saw and check everything running correctly. If all OK, switch off the saw. If not repeat steps 1-7.

Blade storage

If you have several blades you can easily store them into the blade storage compartment, see fig 34.

Fig 34-35

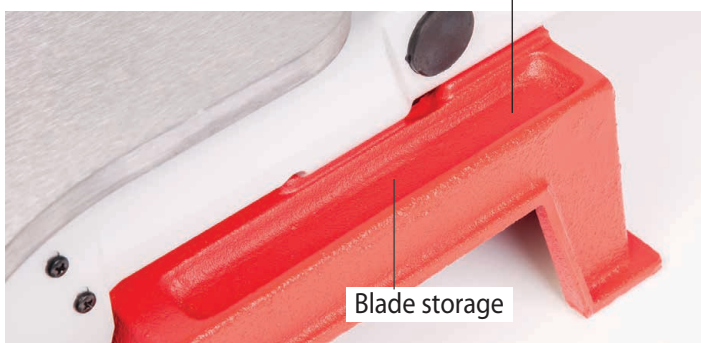
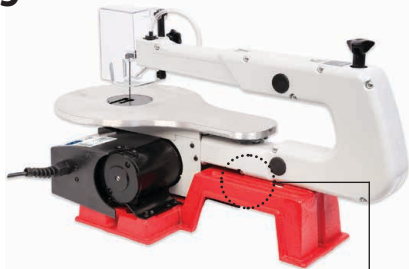

Notes on Saw Blades



BLADES BREAK FOR FIVE PRINCIPAL REASONS

1. Too much tension or too little tension on the blade.
2. Overworking the blade by feeding the work piece too fast.
3. Twisting or bending the blade by feeding the work piece off-centre.
4. Over use, the blade has reached the end of its useful life.
5. Maximum cutting depth 50mm and exceeding the depth for which it was designed.

Selecting the right Blade

The scroll saw will accept a wide variety of blade widths and thicknesses. The width of the blade, the thickness of the blade and the number of teeth per inch (TPI) are determined by the type of material and size of the radius being cut. Here are several examples:

TPI	WIDTH	THICKNESS	MATERIAL
10	2.8mm 0.11"	0.5mm 0.020"	Medium curves on 114" to 1-3/4" wood, wallboard, hardboard.
15	2.8mm 0.11"	0.5mm 0.020"	Same as above, plus wood 1/8" to 1-1/2" thick
18	2.4mm 0.095"	0.25mm 0.010"	Extra thin cuts on soft woods to 1/4" and parquetry

As a general rule, select the narrowest blades recommended for intricate curve cutting and widest blades for straight and large curve operations.

See our full range of 'Pegas' scroll saw blades and accessories in our catalogue or visit us at axminstertools.com

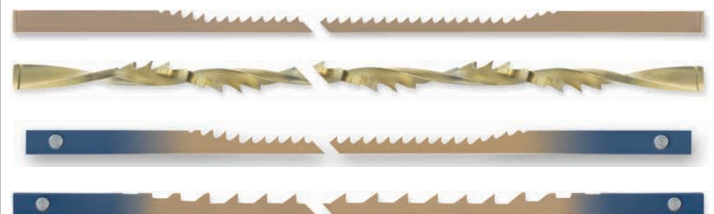



DISCONNECT THE SCROLL SAW FROM THE MAINS BEFORE CONTINUING!

Checking & Replacing the Motor Brushes

After a period of time the scroll saws motor brushes are due to wear and may need replacing, please follow the instruction below for checking and replacing the brushes.

1. There are two motor brush ports one on either side of the motor assembly, using a small flat head screwdriver remove one of the motor's brush access plugs and place safely aside, see fig 36-37-38.

Fig 36-37-38

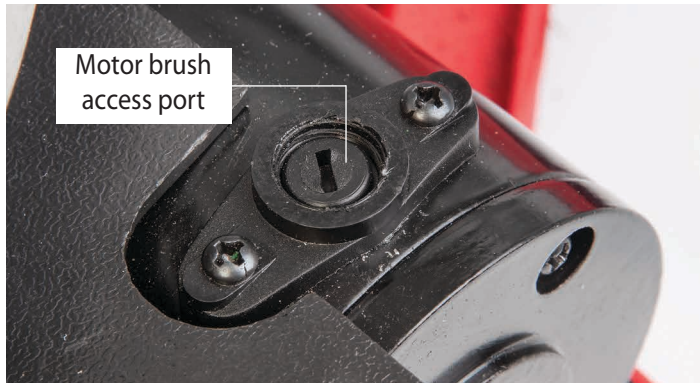

NOTE: Be careful when removing the plug, the motor brush is sprung loaded.

Fig 39

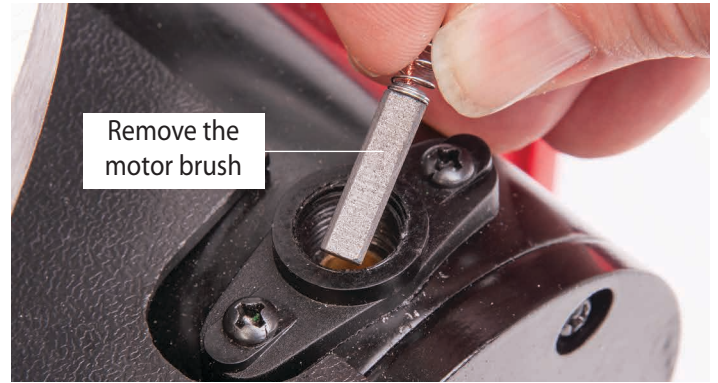

NOTE: Take careful note of the orientation of the brushes when you remove them, remember that they have bedded themselves to the profile of the commutator in that position. If you fit them reversed they may not be in exactly the same position, which can cause excessive sparking and heat until they have re-bedded themselves.

2. Carefully remove the motor brush, see fig 39. Check the brush for signs of wear. If it's O.K. re-fit. If the brush has worn down to a third of its length replace with a new one.

3. Turn the scroll saw on its side allowing access to the other brush access port, see fig 40-41.

Fig 41-42

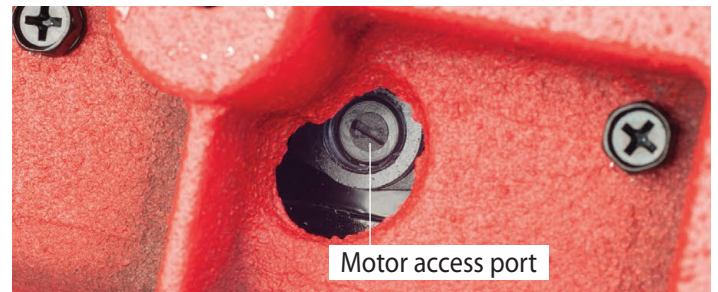
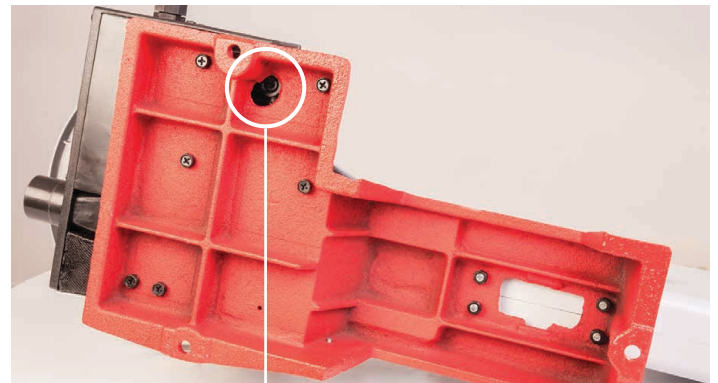

General Maintenance

The motor is permanently lubricated. Do not try to oil the motor bearings or service any internal parts of the motor. If the power cord is worn, frayed, cut or damaged, contact Axminster Tools & Machinery. Do not try to patch it up with electrical tape, this could lead to more trouble.



WARNING! WEAR A DUST MASK AND EYE PROTECTION.

Cleaning

1. Remove the scroll saws side access panel and table insert plate. Using an 'M' class Vacuum Cleaner, clean the accumulated dust from inside the lower housing that included the motor assembly, rocker arm, lower and upper blade holders, table and the table insert void, see fig 43-44. 4.

Fig 43-44

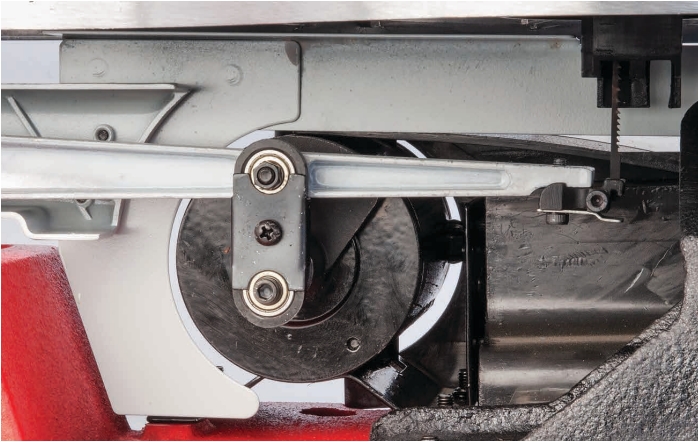

2. If you have finished using the scroll saw, clean above and below the work table and wipe the scroll saw over, see fig 43-44.

3. If the scroll saw is not going to be used for a period of time, use 'Ambersil Dry PTFE Film Antistick', spray, code 952137 over the work table to prevent the table from rusting and place a dust sheet over the scroll saw.

4. If the scroll saw is not going to be used for a period of time, use 'Ambersil Dry PTFE Film Antistick', spray over the work table and place a dust sheet over the saw.



Rocker Arm Bearing Bushes

After a period of use it is recommended to lightly oil the upper and lower rocker arm bearings, see fig 45-46-47.

Fig 45-46-47

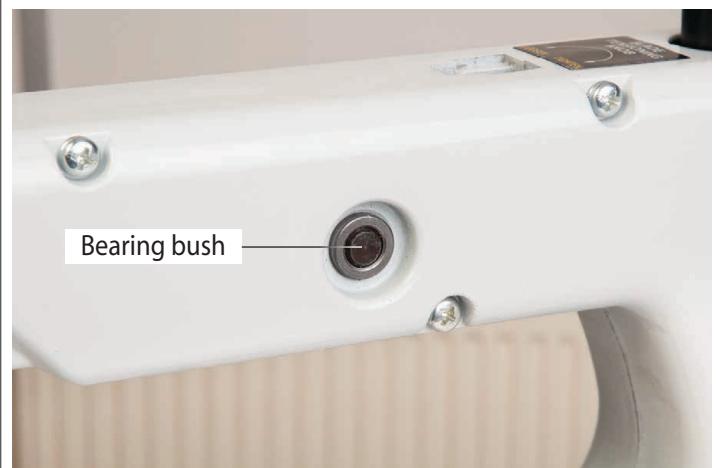

PROBLEM	PROBABLE CAUSES	SUGGESTED REMEDY
Breaking Blades	<ol style="list-style-type: none"> 1. Incorrect tension. 2. Overworked (worn out) blade. 3. Wrong blade being used. 4. Twisting blade in wood. 	<ol style="list-style-type: none"> 1 Adjust blade tension. 2. Reduce feed rate or replace blade. 3. Use narrow blades for thin wood, wider blades for thicker wood. 4. Avoid side pressure on blade.
Motor will Not Run	<ol style="list-style-type: none"> 1. Defective cord, plug or outlet 2. Defective motor. 	<ol style="list-style-type: none"> 1. Unplug saw, replace defective parts. 2. Repairs MUST be made by a qualified technician. Call Axminster Tool Centre. (Technical Sales Phone: 0800 371822).
Excessive Vibration (Some vibration is inevitable when the saw and motor are running)	<ol style="list-style-type: none"> 1. Improper mounting of saw. 2. Unsuitable mounting surface. 3. Loose table. 4. Motor mount is loose 	<ol style="list-style-type: none"> 1. See proper mounting instructions. 2. Replace plywood workbench surface with solid lumber surface. 3. Tighten table clamping knob. 4. Tighten motor mount screws.

EXPLODED DIAGRAMS/LISTS

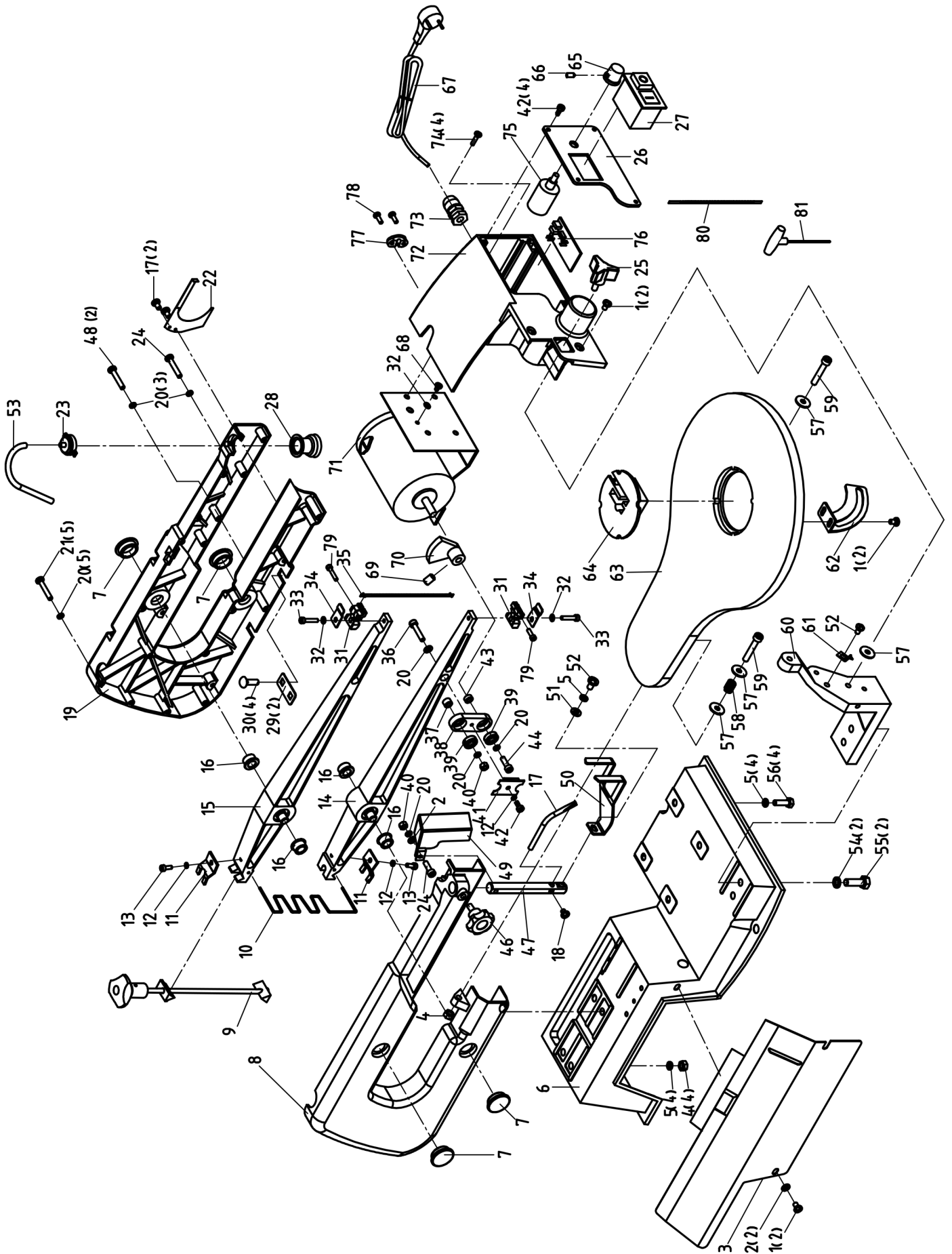

EXPLODED DIAGRAMS/LISTS

No	Description	Specification	QTY
1	Philips screw	M5 x 8	6
2	Flat washer		6
3	Side cover		1
4	Hex nut, Type I	M6	5
5	Standard spring washer	D6	9
6	Base		1
7	Oil cap		4
8	Left stand (arm housing)		1
9	Tension pole assembly		1
10	Extension spring		1
11	Pressure plate		2
12	Standard spring washer	D4	3
13	Hex cylindrical head screw	M4 x 10	2
14	Lower arm		1
15	Upper arm		1
16	Oil bearing		4
17	Blast pipe		1
18	Philips screw	M5 x 6	1
19	Right stand (arm housing)		1
20	Standard spring washer	D5	11
21	Philips screw	M5 x 35	5
22	Protection plate		1
23	Bellows cap		1
24	Philips screw	M5 x 28	2
25	Table lock knob		1
26	Switch box cover		1
27	Switch		1
28	Bellows		1
29	Fixing plate		2
30	Cup head low square neck screw	M6 x 20	4
31	Blade support		2
32	External teeth lock washer	D4	2
33	Hex cylindrical head screw	M4 x 16	2
34	Blade support protection plate		2
35	Blade (pin)	15TPI	1
36	Hex cylindrical head screw	M5 x 25	1
37	Big cushion		1
38	Eccentricity connector assembly		1
39	Radial ball bearing with dust cover		2
40	Hex nut, Type I	M5	2

41	Connection pressure plate		1
42	Self tapping screw	ST4.2 x 9.5	5
43	Small cushion		1
44	Hex cylindrical head screw	M5 x 16	1
46	Pressure rod lock knob		1
47	Pressure rod		1
48	Philips screw	M5 x 30	2
49	Blade guard		1
50	Fender bracket		1
51	Flat washer	D6	1
52	Philips screw	M6 x 10	2
53	PVC pipe		1
54	Standard spring washer	D8	2
55	Hex cylindrical head screw	M8 x 25	2
56	Hex bolt	M6 x 20	4
57	Big flat washer	D6	4
58	Pressure spring		1
59	Hex cylindrical head screw	M6 x 35	2
60	Work table bracket		1
61	Pointer		1
62	Miter gauge		1
63	Work table		1
64	Work table insert		1
65	Speed adjusting knob		1
66	Hex flat end set screw	M5 x 6	1
67	Power cord		1
68	Philips screw	M4 x 8	2
69	Hex flat end set screw	M8 x 12	1
70	Eccentric wheel		1
71	DC motor		1
72	Switch box		1
73	Strain relief		1
74	Philips screw	M4 x 10	4
75	Potentiometer		1
76	Circuit Board	240V	1
77	Strain relief plate		1
78	Philips screw	M4 x 12	2
79	Hex cylindrical head screw	M4 x 16	2
80	Blade (pinless)	18 TPI	1
81	Wrench Type T	S=3	1

WIRING DIAGRAM

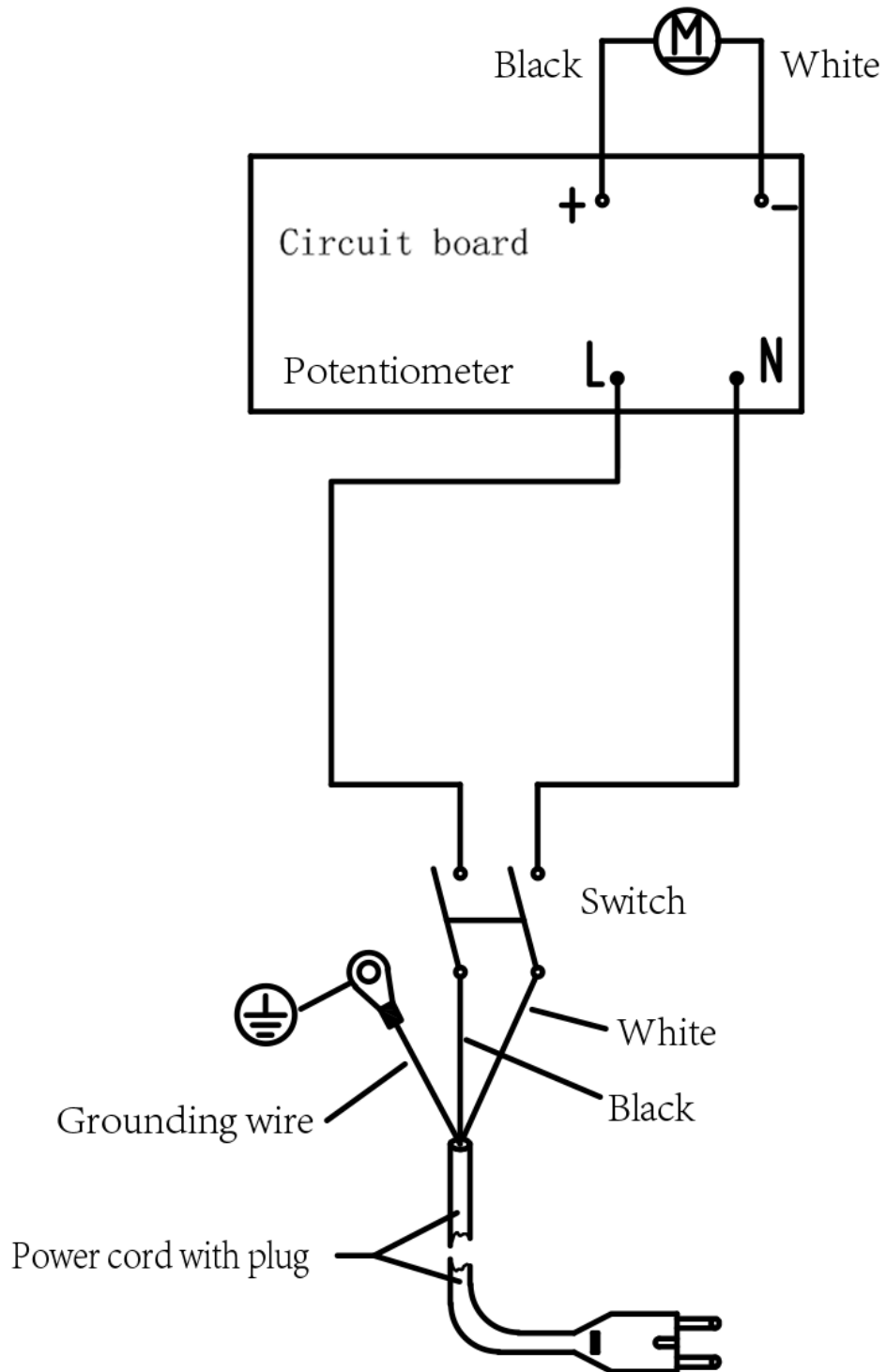



Axminster Tool Centre Ltd



**UK DECLARATION OF CONFORMITY
'original'**

Product model: Axminster Tools AW405FS Scroll Saw

Name and address of the manufacturer: Axminster Tool Centre Ltd, Unit 10 Weycroft Avenue, Axminster, Devon EX13 5PH, United Kingdom

This declaration of conformity is issued under the sole responsibility of the manufacturer.

Object of the declaration: Axminster Tools AW405FS Scroll Saw

The object of the declaration described above is in conformity with the relevant GB legislation:

Supply of Machinery (Safety) Regulations 2008 as amended.
Electromagnetic Compatibility Regulations 2016 as amended.

References to the relevant harmonised standards used or references to the other technical specifications in relation to which conformity is declared:

EN 62841-1:2015 Electric Motor-Operated Hand-Held, Transportable Tools and Lawn and Garden Machinery - Safety - Part 1: General requirements

EN 60204-1:2018 Safety of machinery - Electrical equipment of machines - Part 1: General requirements

Additional information:

Name and address of person authorised to compile the technical file: Axminster Tool Centre Ltd, Unit 10 Weycroft Avenue, Axminster, Devon EX13 5PH, United Kingdom

The machinery fulfils all relevant provisions of Supply of Machinery (Safety) Regulations 2008 as amended.

Signed for and behalf of: Axminster Tool Centre Ltd;

(place and date of issue): Axminster, Devon, United Kingdom, 5/12/22

(name, function): Andrew Parkhouse, Supply Chain Director

Signature:



Axminster Tool Centre Ltd



EC DECLARATION OF CONFORMITY 'original'

Product model: Axminster Tools AW405FS Scroll Saw

Name and address of the manufacturer: Axminster Tool Centre Ltd, Unit 10 Weycroft Avenue, Axminster, Devon EX13 5PH, United Kingdom

This declaration of conformity is issued under the sole responsibility of the manufacturer.

Object of the declaration: Axminster Tools AW405FS Scroll Saw

The object of the declaration described above is in conformity with the relevant GB legislation:

Supply of Machinery (Safety) Regulations 2008 as amended.
Electromagnetic Compatibility Regulations 2016 as amended.

References to the relevant harmonised standards used or references to the other technical specifications in relation to which conformity is declared:

EN 62841-1:2015 Electric Motor-Operated Hand-Held, Transportable Tools and Lawn and Garden Machinery - Safety - Part 1: General requirements

EN 60204-1:2018 Safety of machinery - Electrical equipment of machines - Part 1: General requirements

Additional information:

Name and address of person authorised to compile the technical file: Axminster Tool Centre Ltd, Unit 10 Weycroft Avenue, Axminster, Devon EX13 5PH, United Kingdom

The machinery fulfils all relevant provisions of Supply of Machinery (Safety) Regulations 2008 as amended.

Signed for and behalf of: Axminster Tool Centre Ltd;

(place and date of issue): Axminster, Devon, United Kingdom, 5/12/22

(name, function): Andrew Parkhouse, Supply Chain Director

Signature:

The Axminster guarantee

Buy with confidence from Axminster!

So sure are we of the quality, we cover all parts and labour free of charge for three years!



For more information visit axminstertools.com/3years



The packaging is suitable for recycling.
Please dispose of it in a responsible manner.



EU Countries Only

Do not dispose of electric tools together with household waste material.
By law they must be collected and recycled separately.



Axminster Tools, Axminster Devon EX13 5PH

axminstertools.com