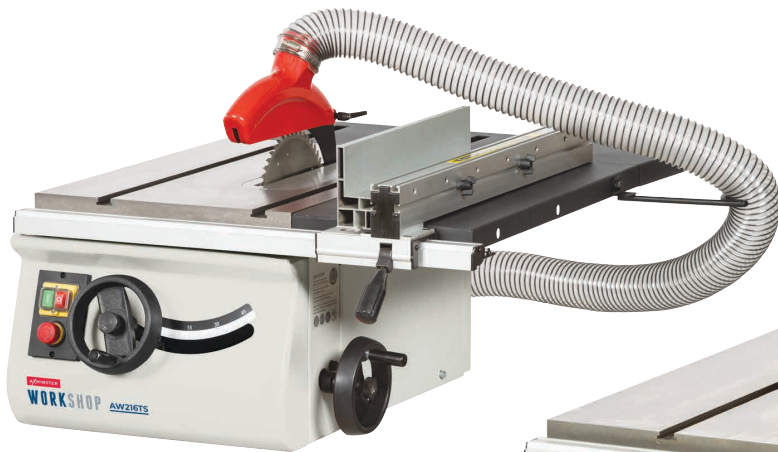
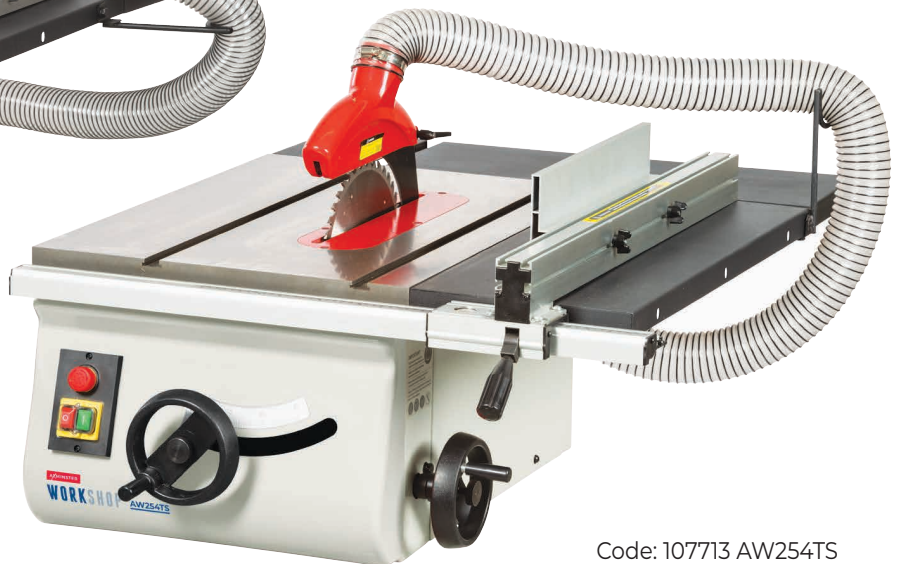


AW216TS & AW254TS

216mm & 254mm Table Saw



Code: 107712 AW216TS



Code: 107713 AW254TS



Floor Stand

Code: 104931 for AW216TS
Code: 106804 for AW254TS



Cabinet Stand

Code: 104932 for AW216TS
Code: 106806 for AW254TS



Left Hand Extension Table

Code: 106808 for AW216TS
Code: 106809 for AW254TS




Sliding Table Kit

Code: 104930 for AW216TS
Code: 106805 for AW254TS



INDEX OF CONTENTS

EU Declaration of Conformity	02
What's Included	03
Optional Accessories	04-05-06
General Instructions for 230V Machines	06
Specific Instructions for Table Saws	07
Specification	08
Assembly	08-09-10-11-12-13-14-15-16-17
Illustration and Parts Description	18-19-20-21
Set Up and Adjustment	22-23-23-24-25
Operating Instructions	26
Changing the Saw Blade	27
Maintenance	28
Exploded Diagrams/Lists	29-30-31-32-33-34-35-36-38-7-38
Wiring Diagram	39

<p>Cert No: MJ2320,MJ2325R, MJ2325G-2, MJ2331-2, MJ2330</p> <p>Axminster tool Centre Ltd Axminster Devon EX13 5PH UK axminstertools.com declares that the machinery described:-</p> <table border="1"> <tr> <td>Type</td> <td>Table Saw</td> </tr> <tr> <td>Model</td> <td>AW216TS & AW254TS</td> </tr> </table> <p>Signed </p> <p>Andrew Parkhouse Operations Director</p> <p>Date: 06/12/2018</p>	Type	Table Saw	Model	AW216TS & AW254TS	<p>EU Declaration of Conformity</p> <p>This machine complies with the following directives:</p> <p>2006/42/EC EN 1870-19:2013 EN 60204-1:2006+A1+AC</p> <p>and conforms to the machinery example for which the EC Type-Examination Certificate No BM 50424431 has been issued by Laizhou Fulin Machinery Co., Ltd. at: Wenchang Road Street Nanwuli Industry Yard Laizhou, Shandong261400 China and complies with the relevant essential health and safety requirements.</p>
Type	Table Saw				
Model	AW216TS & AW254TS				

The symbols below advise the correct safety procedures when using this machine.



Fully read manual and safety instructions before use



Ear protection should be worn



Eye protection should be worn



Dust mask should be worn



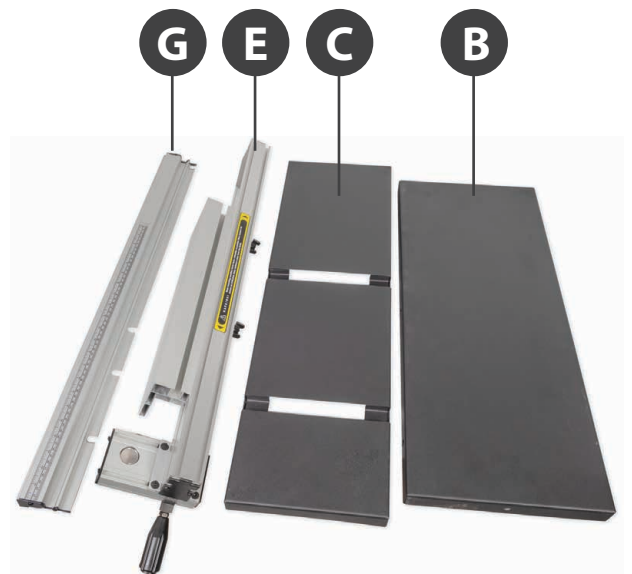
Two Man Assembly



HAZARD

WHAT'S INCLUDED

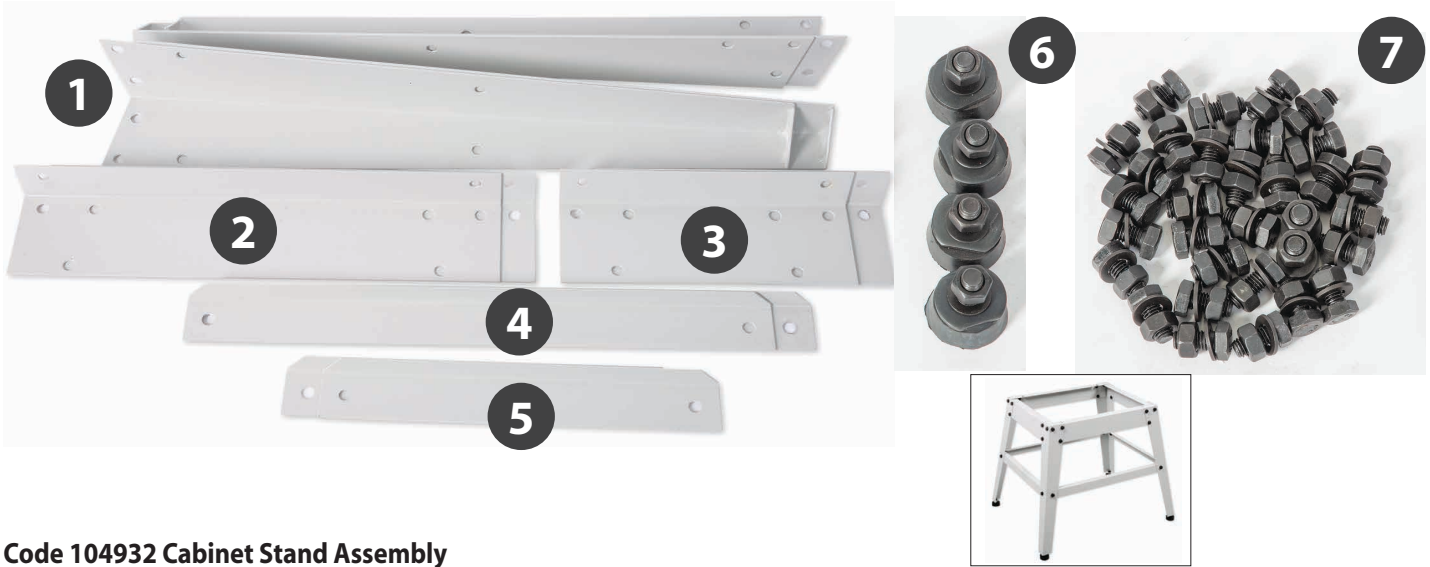
Quantity	Item	Part	Model Number
			AW216TS, AW254TS
1	Basic Table Saw	A	1 Outer Flexible Hose
1	Side Extension Table	B	4 Hose Clips
1	Rear Extension Table	C	1 Push Stick
2	Operating Wheels with Clamping Knobs	D	1 Blade Locking Bar
1	Rip Fence Assembly	E	1 24mm Spanner
1	Rip Fence Extension	F	1 13-15mm Spanner
1	Rip Fence Rail with Scale	G	4 Hex Keys 6,5,3,2mm
1	Riving Knife	H	1 Handle Hex Key
1	Hose Support Bracket	I	4 M8 Threaded Feet with nut/washer
1	Dust Extraction Moulding	J	9 M8 Bolts, washers & one nut
1	Crown Guard with Clamping Handle	K	1 Inner Flexible Hose
			1 Base Plate
			L
			M
			N
			O
			P
			Q
			R
			S
			T
			U
			V
			W



OPTIONAL ACCESSORIES

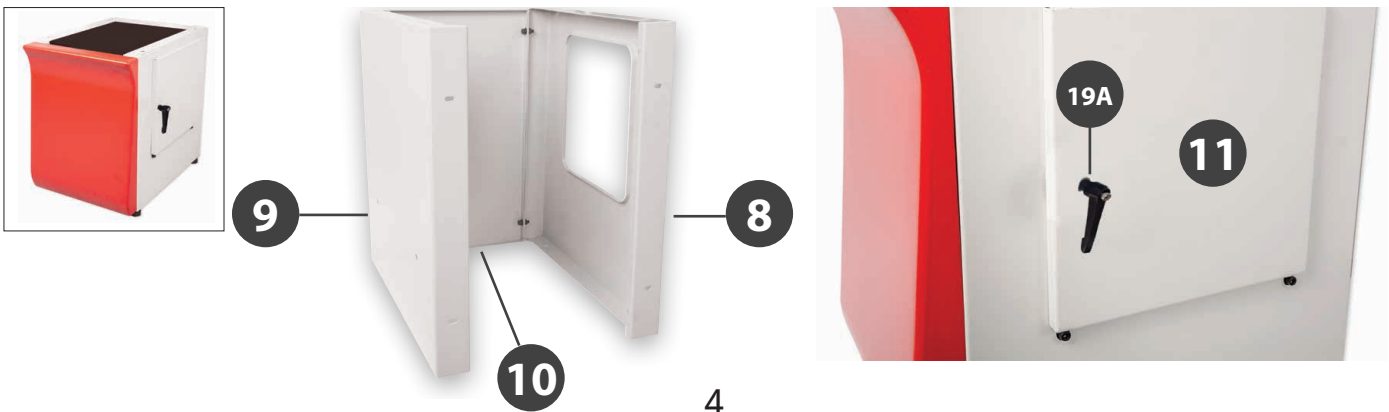
Code 104931 Floor Stand Assembly

Quantity	Item	Part
4	Leg Brackets	1
2	Long Upper Support Struts	2
2	Short Upper Support Struts	3
2	Long Lower Support Struts	4
2	Short Lower Support Struts	5
2	Threaded Rubber Feet	6
1	Floor Stand Bag of Fixings	7



Code 104932 Cabinet Stand Assembly

Quantity	Item	Part
1	Right Side Panel with Door Cut out	8
1	Left Side Panel	9
1	Rear Panel	10
1	Door Panel	11
1	Cabinet Shelf	12
2	Upper and Lower Support Struts	13
1	Moulded Red Front Panel	14
	Base Plate (W) (Supplied with Main Saw Assembly)	15
4	M8 Threaded Feet with Nut/Washer	16
11	M8 Cap head Bolts with Nut and Washers	17
4	Short Cap head Screws and Washer	18
5	M8 Cap head Bolts and Washers	19
1	Door Locking Handle & Nut	19A



OPTIONAL ACCESSORIES



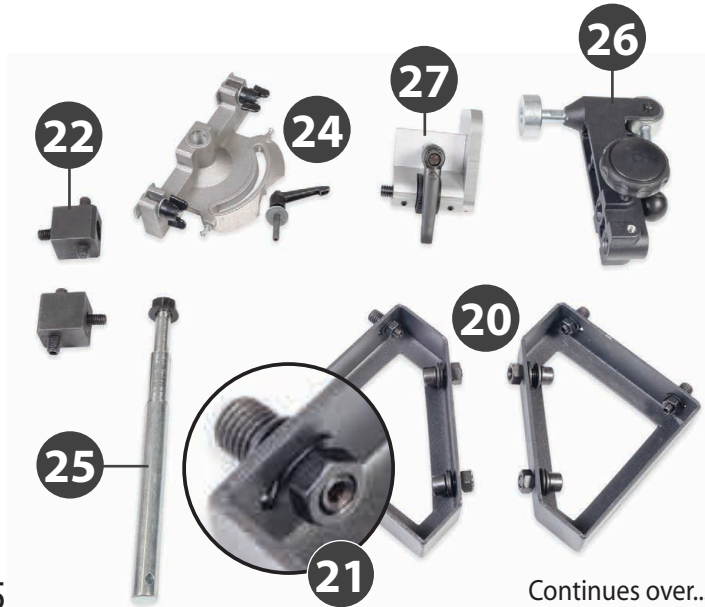
Code 104930 Sliding Table Kit (AW216TS)

Quantity	Item	Part
2	Sliding Carriage Support Bracket	20
2	Threaded Adjuster Assembly	21
2	Height Adjusting Blocks	22
1	Hex Key	23
1	Fence Mitre Casting with Lift & Shift Handle	24
1	Tool Post for Hold Down Clamp	25
1	Hold Down Clamp	26
1	Fence Distance Stop with Micro Adjuster	27
1	Sliding Table Assembly	28
1	Fence	29
1	Sliding Carriage Assembly	30



Code 106805 Sliding Table Kit (AW254TS)

Quantity	Item	Part
2	Sliding Carriage Support Bracket	20
2	Threaded Adjuster Assembly	21
2	Height Adjusting Blocks	22
1	Hex Key	23
1	Fence Mitre Casting with Lift & Shift Handle	24
1	Tool Post for Hold Down Clamp	25
1	Hold Down Clamp	26
1	Fence Distance Stop with Micro Adjuster	27
1	Sliding Table Assembly	28
1	Fence	29
1	Sliding Carriage Assembly	30



OPTIONAL ACCESSORIES



Quantity	Item	Part
1	Table Insert for the AW216TS Code: 104933	31
	Table Insert for the AW254TS Code: 106807	
1	19mm Mitre Fence	32
1	Left Hand Extension Table with Long Rip Fence Rail/Scale AW216TS Code: 106808	33
1	Left Hand Extension Table with Long Rip Fence Rail/Scale AW254TS Code: 106809	

GENERAL INSTRUCTIONS FOR 230V MACHINES

The following will enable you to observe good working practices, keep yourself and fellow workers safe and maintain your tools and equipment in good working order.



WARNING!! KEEP TOOLS AND EQUIPMENT OUT OF REACH OF YOUNG CHILDREN



KEEP WORK AREA AS UNCLUTTERED AS IS PRACTICAL. UNDER NO CIRCUMSTANCES SHOULD CHILDREN BE ALLOWED IN WORK AREAS.

Mains Powered Tools

- Tools are supplied with an attached 13 Amp plug.
- Inspect the cable and plug to ensure that neither are damaged. Repair if necessary by a suitably qualified person.
- Do not use when or where it is liable to get wet.

Workplace

- Do not use 230V a.c. powered tools anywhere within a site area that is flooded.
- Keep machine clean.
- Leave machine unplugged until work is about to commence.
- Always disconnect by pulling on the plug body and not the cable.

- Carry out a final check e.g. check the cutting tool is securely tightened in the machine and the correct speed and function set.
- Ensure you are comfortable before you start work, balanced, not reaching etc.
- Wear appropriate safety clothing, goggles, gloves, masks etc. Wear ear defenders at all times.
- If you have long hair wear a hair net or helmet to prevent it being caught up in the rotating parts of the machine.
- Consideration should be given to the removal of rings and wristwatches.
- Consideration should also be given to non-slip footwear etc.
- If another person is to use the machine, ensure they are suitably qualified to use it.
- Do not use the machine if you are tired or distracted
- Do not use this machine within the designated safety areas of flammable liquid stores or in areas where there may be volatile gases.
- Check cutters are correct type and size, are undamaged and are kept clean and sharp, this will maintain their operating performance and lessen the loading on the machine.
- **OBSERVE....** make sure you know what is happening around you and **USE YOUR COMMON SENSE.**

SPECIFIC INSTRUCTIONS FOR TABLE SAWS

Make sure the saw blade is the correct type for the job in hand. Do not force the saw, if the saw begins to 'stall' you are 'forcing the cut' or over working the saw.

Ensure that the saw blade is clean and sharp.

Resin build up on the blades will increase the friction of the saw passing through the timber, and cause over heating of the blade, blunt teeth will work harder tearing the fibre of the timber as opposed to shearing it, also with subsequent overheating. Both faults unnecessarily load the machine beyond normal usage, and shorten its longevity.

Do not use blades that are deformed in any way.

Do not remove the blade guard. The design of the riving knife on the machine will not allow for slotting or 'blind' grooving, so there is no reason to remove the guard.



FOR YOUR OWN SAFETY NEVER OPERATE THE TABLE SAW WITHOUT THE RIVING KNIFE IN PLACE!

Do not remove the riving knife.

Do not use any blades that cut a smaller kerf than the riving knife thickness. Make sure the riving knife is correctly adjusted to the blade and is securely fastened. If the table insert becomes damaged or broken, and will not support the timber 'up close' to the blade, replace it.



UNDER NO CIRCUMSTANCES SHOULD CHILDREN BE ALLOWED IN THE WORK AREA AND KEEP TOOLS AND EQUIPMENT OUT OF REACH OF YOUNG CHILDREN!



CONNECT A DUST EXTRACTION MACHINE TO THE SAW.

Do not start the saw with the work piece touching the blade.

Do not commence sawing until the blade has run up to full speed.

After switching off, never try to slow the saw down more quickly by applying side pressure (with a piece of wood?) to the blade. Apply the old joiner's adage of never getting hands within one handbreadth of the blade. Leave the machine disconnected from the mains supply until you are about to commence work.

Always disconnect the machine if you are leaving it unattended.

Never leave the vicinity of the machine unless the blade has come to a complete stop.

Do not attempt to carry out any maintenance, corrective work, setting up etc., unless the machine is disconnected from the mains supply. If any tools have been used during setting up procedures, make sure they are removed from the machine and stowed safely away.



USE THE SUPPLIED PUSH STICK WHEN CUTTING SMALL PIECES.

Do not attempt to carry out cross cutting operations 'freehand', always use the mitre fence for small stuff and the sliding carriage for larger work pieces. Do not attempt to 'rip' freehand, always use the guiding facility of the rip fence.

It is perfectly acceptable to support guide and feed the timber with your hands whilst ripping stuff of some length, however, as you approach the blade ensure that the push stick is to hand, and you use it.

Remember the emphasis of the 'push' should be between the blade and the fence and close to the fence. Use your free hand to support and guide the material on the offside of the saw blade and at least 100mm away from it. If the timber does not extend to at least 100mm to the offside of the saw blade, the material possibly does not need guiding or supporting.



WARNING! IF THE SAW JAMS! SWITCH OFF IMMEDIATELY.

Check that there are no foreign objects e.g. old nails, screws, small stones etc embedded in the material you are about to cut. If necessary take a wire brush to the timber before working.

SPECIFICATION

Code	107712
Model	AW216TS
Rating	Workshop
Power	1.1 kW 50Hz 230V 1ph
Blade Dia/Bore	216 mm / 30 mm
Blade Tilt	0° to 45°
Max Depth of Cut @ 45°	45 mm
Max Depth of Cut @ 90°	65 mm
Max Width of Cut with Fence	370 mm
Table Size	570 mm x 400 mm
Table Height	320 mm (bench mounted)
Table Size With Extensions	570 mm x 675 mm
Dust Extraction Outlet	100 mm and 63 mm
Min Extraction Airflow Required	850 m ³ /hr
Overall L x W x H	670 mm x 695 mm x 420 mm
Weight	70 kg

Code	107713
Model	AW254TS
Rating	Workshop
Power	1.5 kW 50Hz 230V 1ph
Blade Dia/Bore	254 mm / 30 mm
Blade Tilt	0° to 45°
Max Depth of Cut @ 45°	56 mm
Max Depth of Cut @ 90°	80 mm
Max Width of Cut with Fence	430 mm
Table Size	485 mm x 680 mm
Table Height	375 mm (bench mounted)
Table Size With Extensions	760 mm x 900 mm
Dust Extraction Outlet	100 mm and 63 mm
Min Extraction Airflow Required	1,000 m ³ /hr
Bench Mounted	1,070 x 800 x 645 mm
Stand/Cabinet Mounted	1,070 x 800 x 1,170 mm
Weight	89 kg

ASSEMBLY

107712-107713 Basic Saw



WARNING! THE SAW IS HEAVY SEEK ASSISTANCE BEFORE LIFTING.

NOTE: If either sand or cabinet has been purchased, assemble them first, see page 12-13. Then mount the stand to the saw before moving the saw and standing it upright.

1. With assistance lift the saw assembly (A) from the box onto a suitable work surface. loosen the two grub screws on the operating wheels (D) and slide each wheel onto the shafts. Nip-up grub screws to securing in place, see fig 01-02. Make sure the screws clamp against the machined face on the shaft. Insert the threaded locking knobs through the centre of each operating wheel and finger tighten.

Fig 01-02

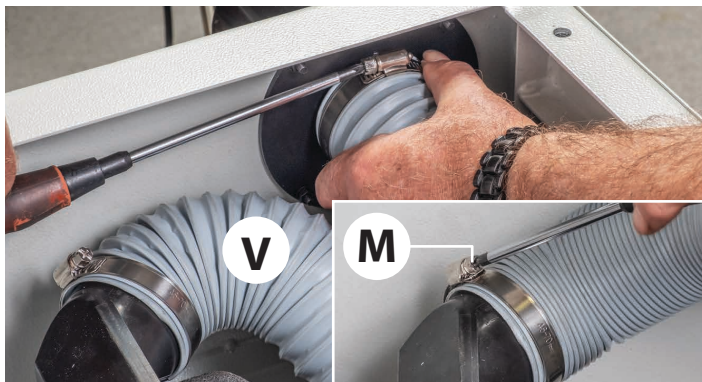


Fig 03-04-05



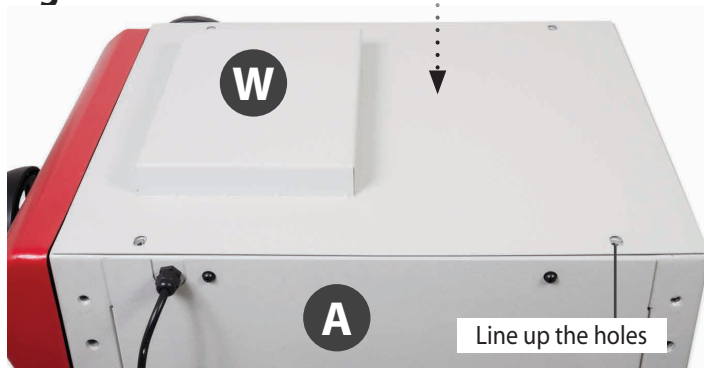
2. Undo and remove the screws, washers & nuts to separate the two parts of the dust extraction moulding (J). Position the inner mounting plate over the machine cut out for the extraction outlet. Repeat for the outer moulding, line up the holes and replace the screws to secure the assembly (J) in position, see fig 03-04-05.

Fig 06-07

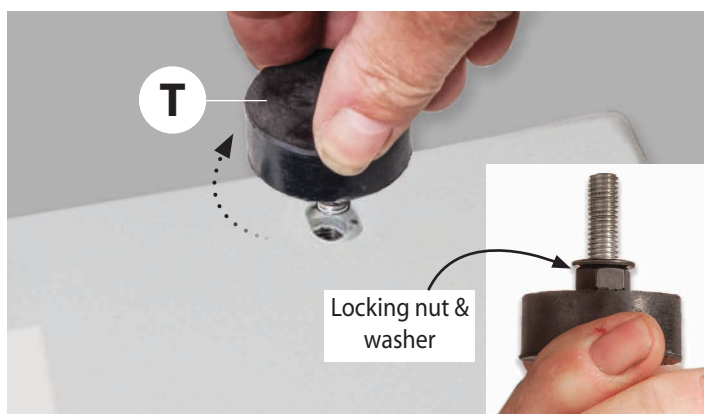


3. Locate the inner flexible hose (V) and two hose clips (M). Place a clip over each end of the hose and secure the hose over the extraction outlets, see fig 06-07.

Fig 08



4. Place the base plate (W) to the base of the saw (A) and align the holes as shown in fig 8. Find the four threaded feet (T), screw each foot in turn into the threaded holes in each corner of the chassis, see fig 09 below.



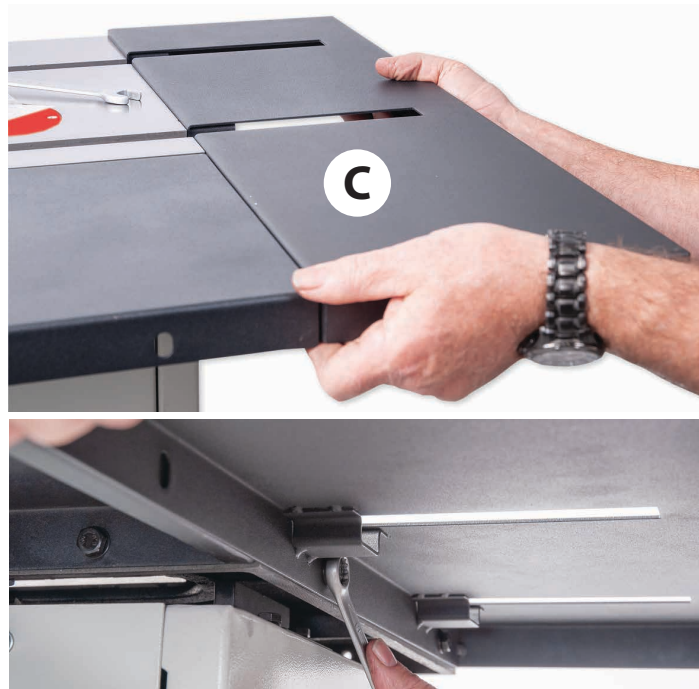
WITH ASSISTANCE TURN THE SAW ASSEMBLY OVER!

5. Lower the saw down, locate the side and rear extension tables (B-C) and M8 bolts/washers (U). Line up the holes in the side extension table (B) with the threaded holes to the side of the main cast iron table. Insert the bolts with washers (U) through the holes and secure the extension table (B) to the main cast iron table, see fig 10-11-12.

Fig 10-11-12

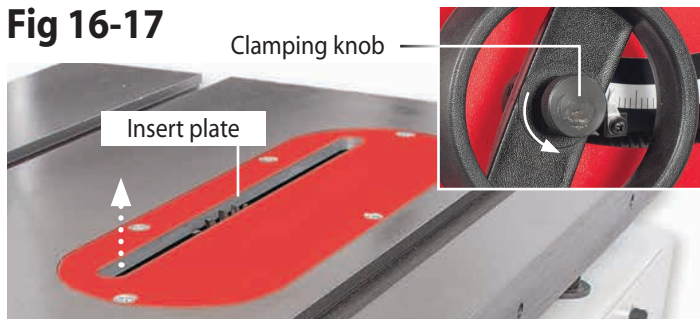


Fig 13-14-15



6. Repeat the procedure for the rear extension table (C). Note: make sure you line up the machined slots in the table with the 19mm mitre 'T' slots in the cast iron table. Secure both extension tables together, see fig 13-14-15.

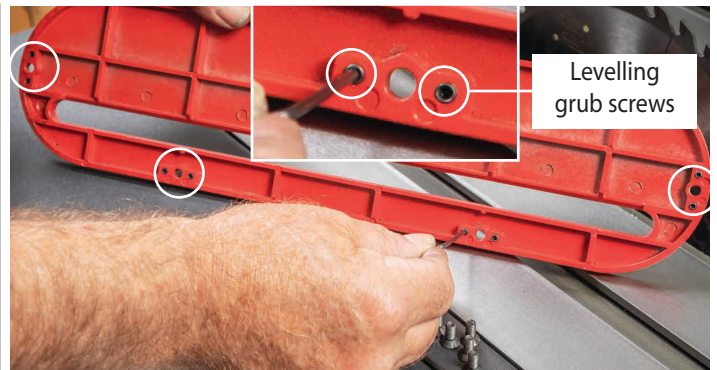
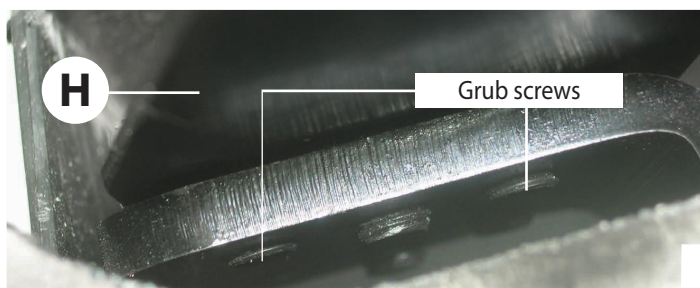
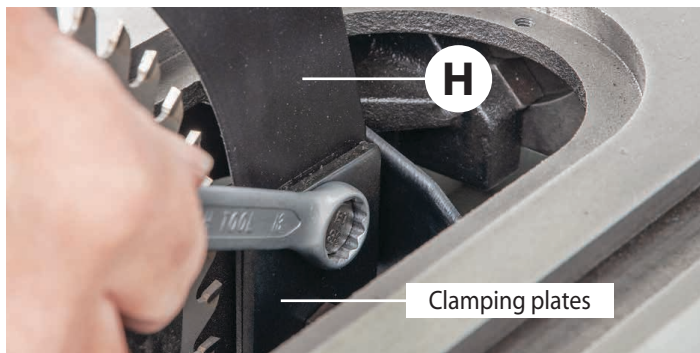
Fig 16-17



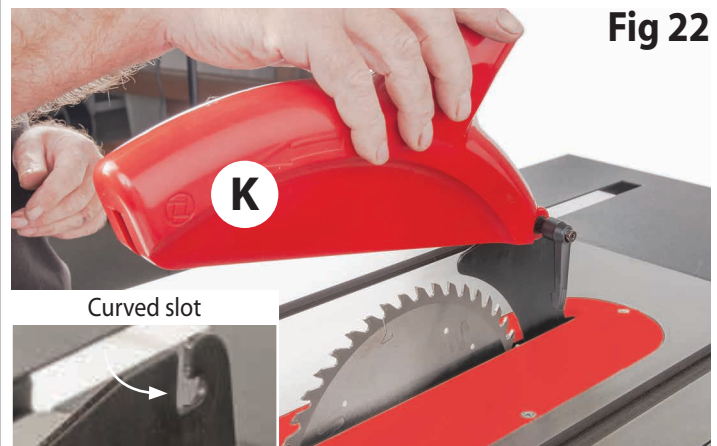
7. Raise the saw by first releasing the rise & fall operating wheel clamping knob, remove the five cross head screws holding the table insert and place safely aside, see 16-17. Raise the saw to its maximum height by turning the operating wheel anti-clockwise.

8. Find the riving knife (H) loosen the two nuts holding the riving knife clamping plates, slide the riving knife down between the two plates and lightly tighten to hold the riving knife in place. Check that the tip of the knife has a clearance of 3-8mm between the blade. Adjust the four grub screws to the opposite side of the clamping plate to align the riving knife with the blade. Tighten the nuts to secure the riving knife in place, see fig18-19-20. Adjust the levelling grub screws on the insert plate so it's level with the main table, see fig 21. Re-secure the insert plate.

Fig 18-19-20-21



9. Locate the crown guard (K), flexible hose (L) and hose clips (M). Loosen the lift & shift handle on the crown guard. Introduce the slot to the rear of the crown guard (K) over the riving knife and slot pin bolt into the curved slot in the riving knife. Tighten the handle, see fig 22.



NOTE: DO NOT OVERTIGHTEN AS THE CROWN GUARD IS PLASTIC AND COULD BE DAMAGED!

10. Locate the flexible hose (L), place a hose clip (M) over one end. Insert the hose over the extraction outlet on the crown guard (K) and tighten the clip. Place the remaining clip over the opposite end of the hose, insert the hose over the extraction out moulding (J) and tighten, see fig 23-24.

Fig 23-34



Fig 35



11. Put to hand four M8 Bolts with washer/nuts (U) and rip fence rail with scale (G). Insert two bolts with washers up through the holes to the underside end of the side extension table (B) and lightly screw on two bolts. Place the remaining two bolts with washer into the threaded holes to the underside of cast iron table, see fig 35. **Note: make sure to give enough clearance between the tables and bolts for the next step.**

12. Line up the machined slots in the rip fence rail (G) with the bolts and slide the rail up against the tables. Nip up the bolts to secure the rail, see fig 36-37.

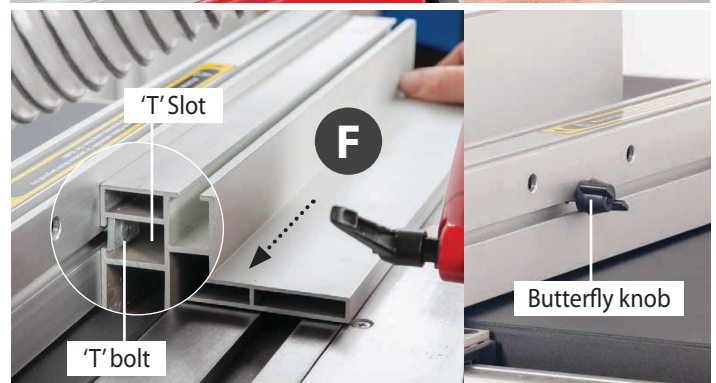
Fig 36-37



13. Locate the rip fence (E) and lower the clamp assembly down over the fence rail (G) and press down the locking lever to secure in position, see fig 38.

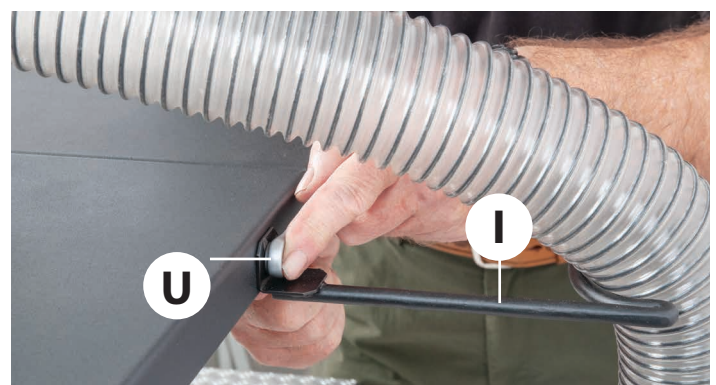
14. Find the rip fence extension (F), slot the two 'T' bolts mounted in the rip fence (E) into the 'T' slot on the fence extension and nip up the butterfly knob clamps, see fig 39. **Note: the extension (F) can be set in two positions, see fig 40.**

Fig 38-39-40



15. Locate the hose support bracket (I) and secure it to the side extension table (B) using a M8 bolt washer/nut (U). Insert the holes (L) into the hose bracket, see fig 41.

Fig 41



16. Place a straight edge across the tables and check they are level and make adjustment until correct.

ASSEMBLY

107712-107713 Basic Saw



AW216TS Table Saw assembled for work bench set up

104931 Optional Floor Stand for AW216TS

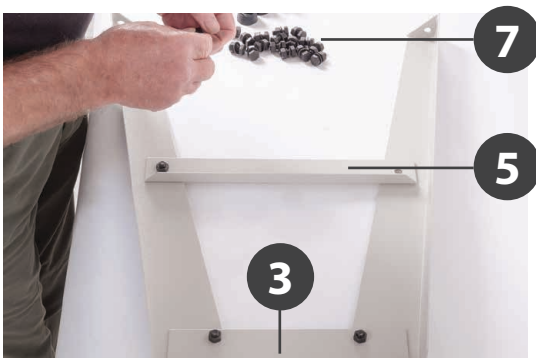
106804 Optional Floor Stand for AW254TS

Locate all the components on page 04 and assemble as follows.

Step 1



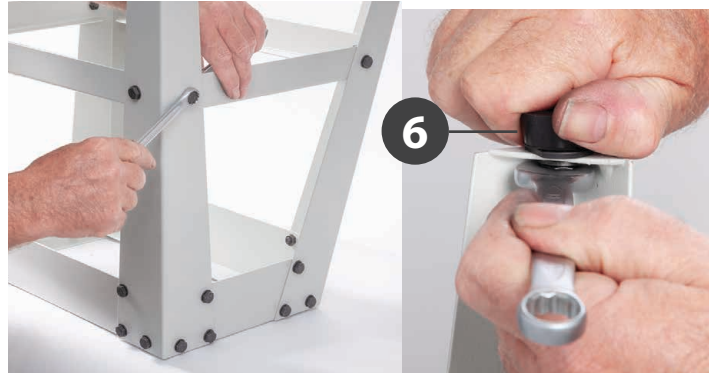
Step 2



Step 3



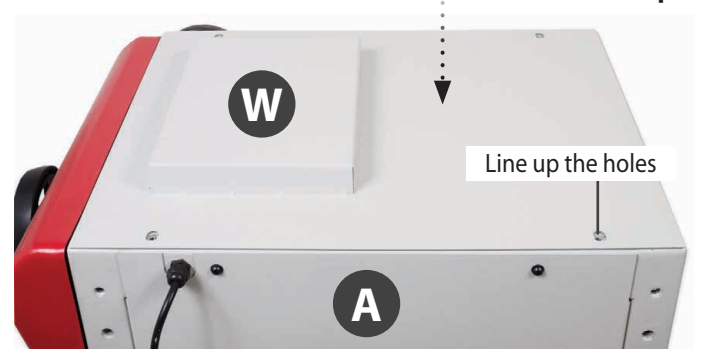
Step 4



Mounting the Stand to the Saw

Remove the rip fence, crown guard and hose and lower saw blade below the table. With assistance turn the saw assembly (A) over & remove the four rubber feet (T). Place the base plate (W) on top and align the holes as shown in step 5. Lower the stand on top of the saw, line up the holes and secure using the caphead bolts & washers (19). Place the assembly upright on the floor, see step 6.

Step 5



Step 6



104932 Optional Cabinet Stand for AW216TS 106806 Optional Cabinet Stand for AW254TS

Locate all the components for the cabinet stand as shown on page 04-05 and follow the instructions below.

Step 1



Step 2



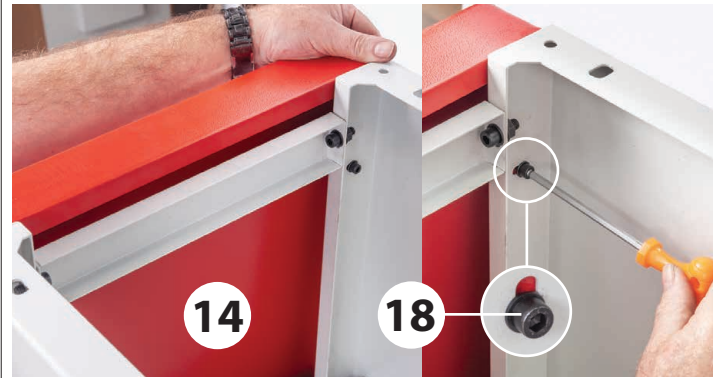
Step 3



Step 4



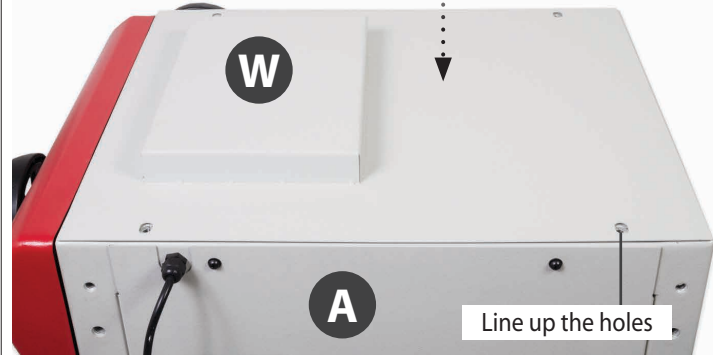
Step 5



Mounting the Cabinet to the Saw

Turn the saw assembly (A) over, place the base plate (W) on top and align the holes as shown in step 6. Turn the cabinet over and place on top of the saw. Align the threaded holes and secure using the caphead bolts & washers (19), see step 7-8 below.

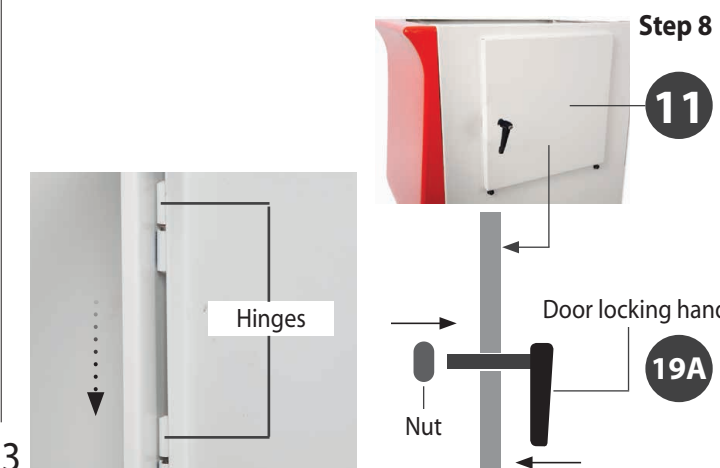
Step 6



Step 7



Step 8



ASSEMBLY

104930 Optional Sliding Table Kit for AW216TS

106805 Optional Sliding Table Kit for AW254TS

1. Locate the carriage support brackets (20). Offer up the elongated slots in both support brackets with the threaded holes in the side of the saw assembly (A). Using the supplied Hex key (R) secure the bracket in place using the threaded adjusters (21), see fig 42-43-44.

Fig 42-43-44

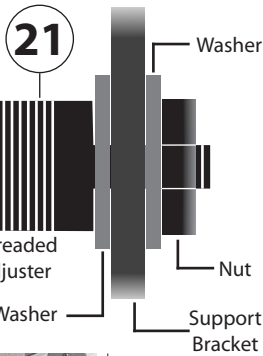
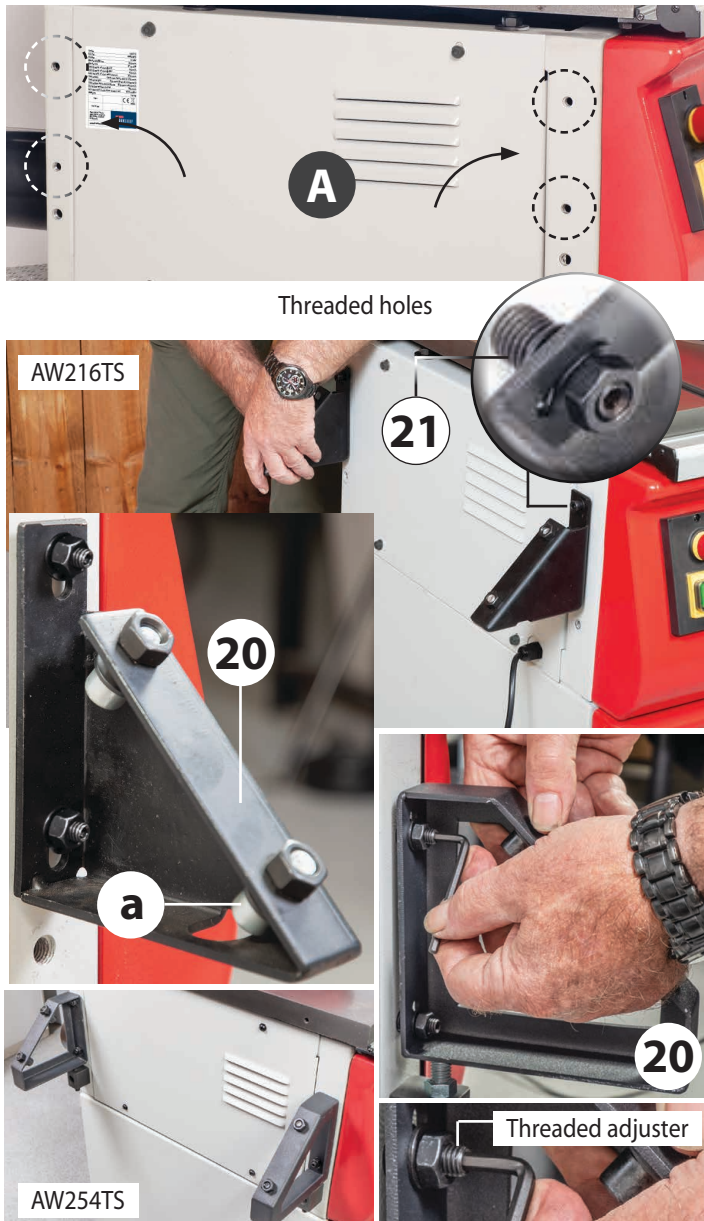


Fig 45-46-47

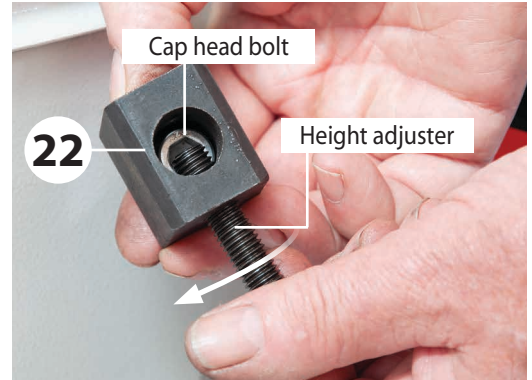


Fig 48-49

2. Find the two height adjusting blocks (22), unscrew the height adjuster thread & remove the locking nut to give you access to the cap head bolt, see fig 45. Fix the blocks against the saw using the threaded holes beneath each bracket, see fig 46. Replace the height adjuster locking nut & screw the adjuster thread, so it touches the base of the bracket (20), see fig 47.

3. Locate the sliding carriage (30), loosen the two cap head bolts/nuts (a) on the brackets (20). Introduce the first two nuts into the 'T' slot rails on either side of the carriage (30) and slide on, repeat for the opposite end. Adjust the carriage to your preference and nip up the four bolts, see fig 48-49.

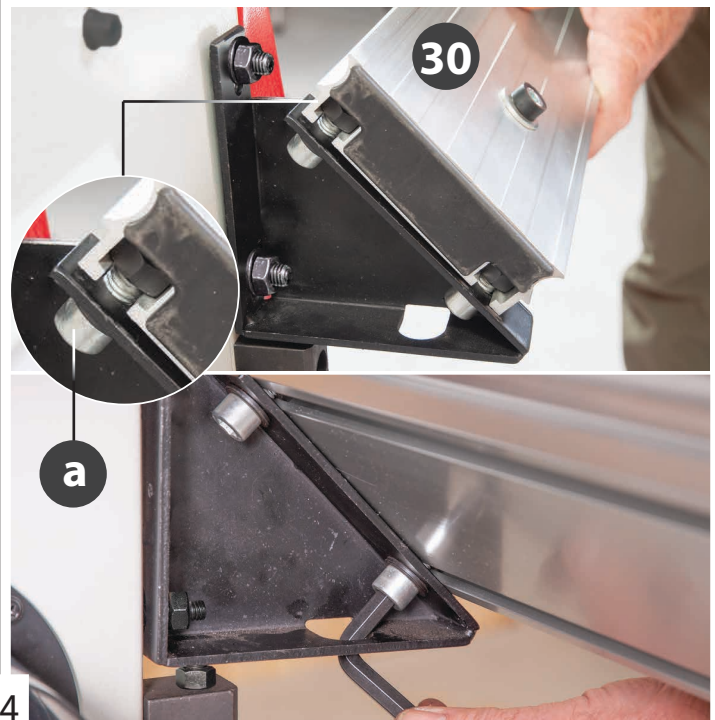
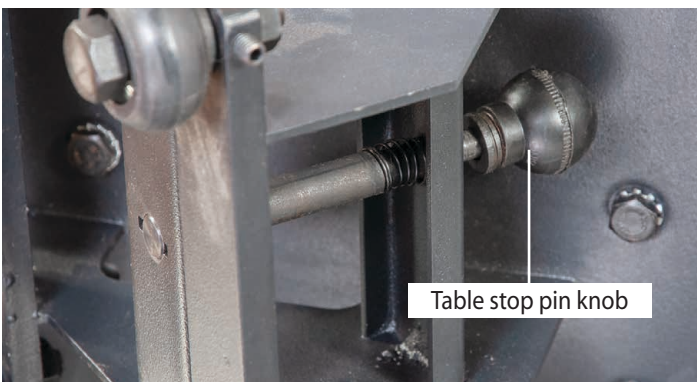
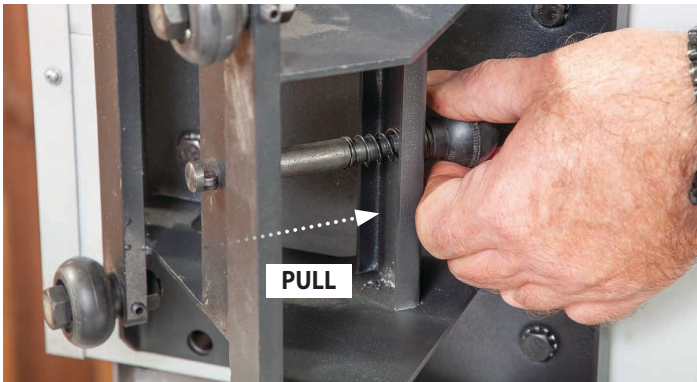


Fig 50-51-52



4. Locate the sliding table (28), turn the table over and pull out and twist the table stop pin knob so it's in the unlocked position, see fig 50-51.

5. Position the sliding table (28) so the wheel assembly engages either side of the sliding carriage (30) and roll on the table, see fig 52. Reengage the stop pin and slide it up against the stop on the carriage, see fig 53.

Fig 53

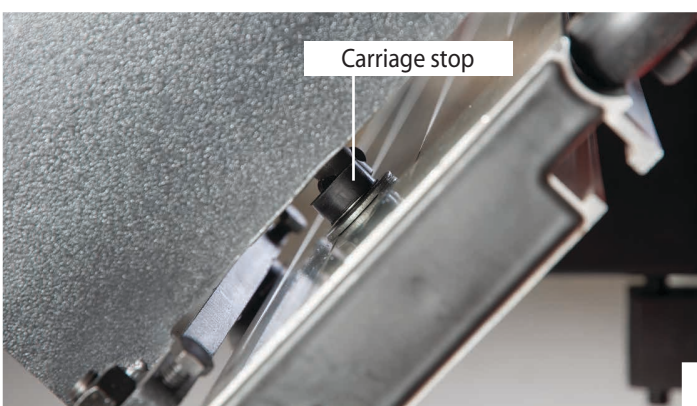
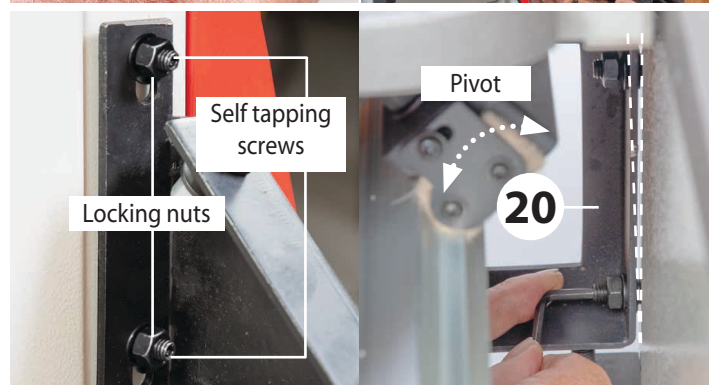
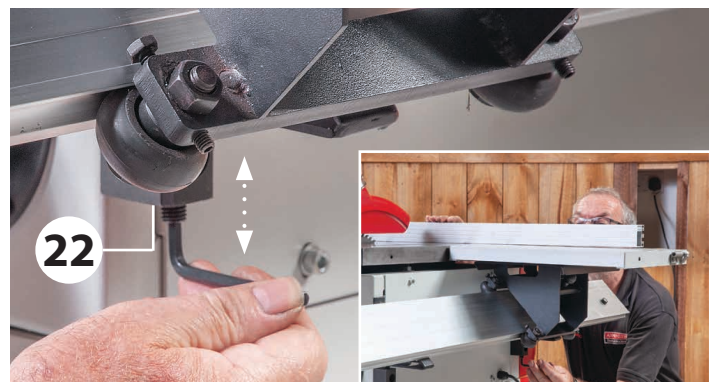


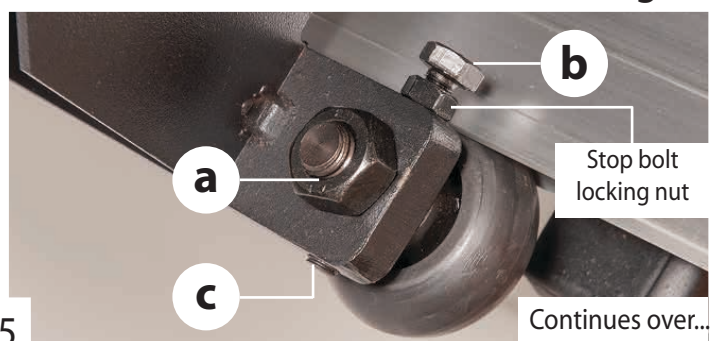
Fig 54-55-56-57



6. Place a level across both tables, using the supplied hex key (R) adjust both height adjusting blocks (22) and the threaded adjusters on each support bracket (20), until the sliding table (28) is level with the cast iron table, see fig 54-55-56-57.

7. The sliding table (28) can also be raised or lowered independently in small increments by adjusting the wheel assembly, see fig 58. Adjust each wheel in turn by loosening the wheel locking nut (a), adjust the stop bolt (b) and grub screw (c) until you are correct, see fig 59 on next page. Nip-up the wheel nuts (a) and the stop bolt (b) locking nut.

Fig 58



Continues over...

Fig 59



8. Locate the fence mitre casting and lift and shift hand (24). Insert the locking handle with washer through the elongated slot in the fence mitre casting and down into the threaded hole in the scale casting. This is mounted to the side of the sliding table (28), see fig 60-61.

Fig 60-61

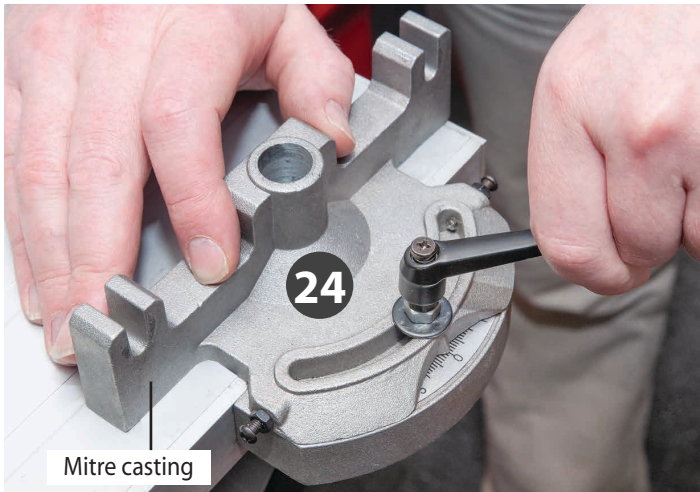
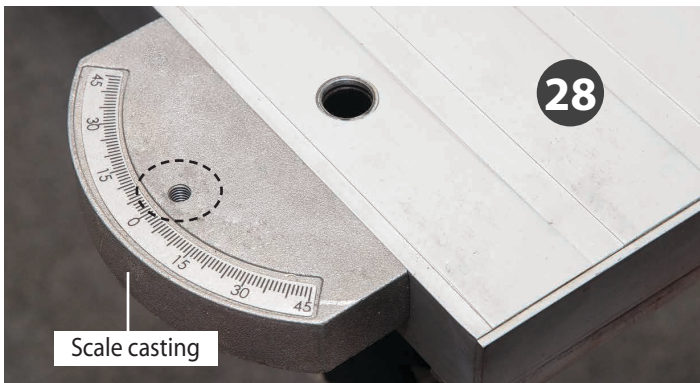
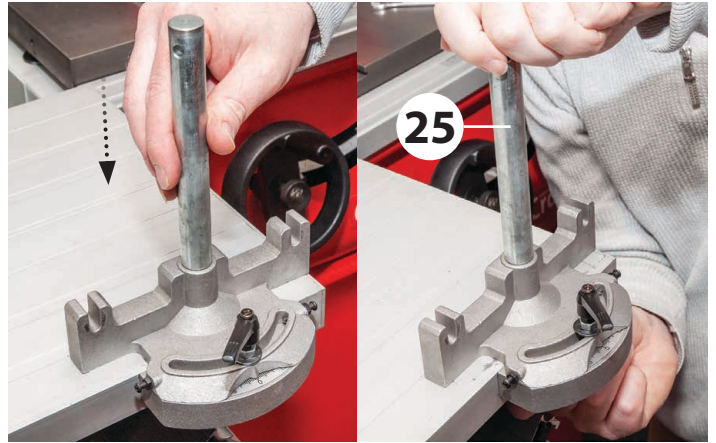


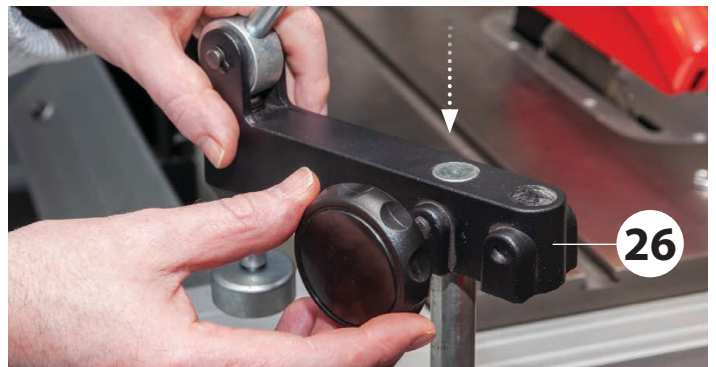
Fig 62



9. Remove the washer/nut from the tool post (25), insert the post down through the machined holes in both mitre casting (24) and sliding table (28) and secure using the washer/nut, see fig 62.

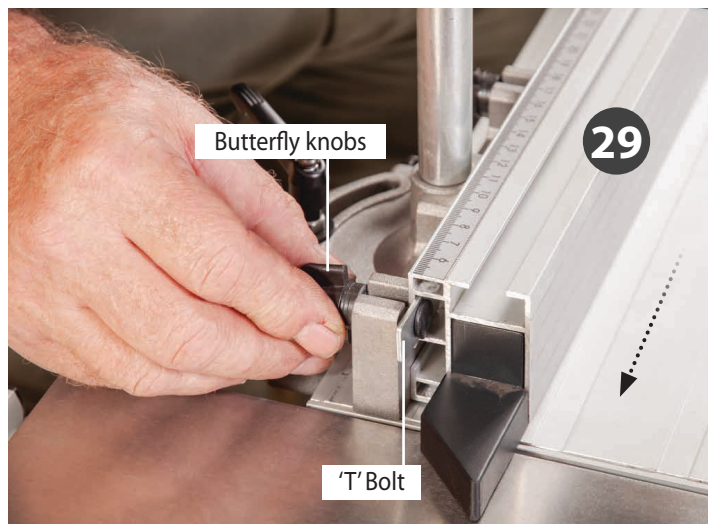
10. Loosen the hold down clamping knob (26) and slide the assembly down the tool post (25) and clamp in position, see fig 63.

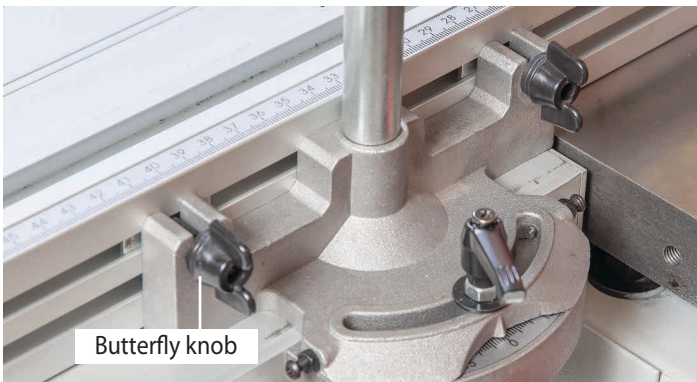
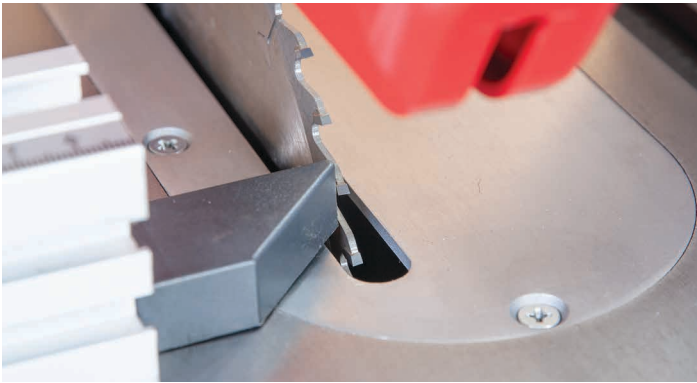
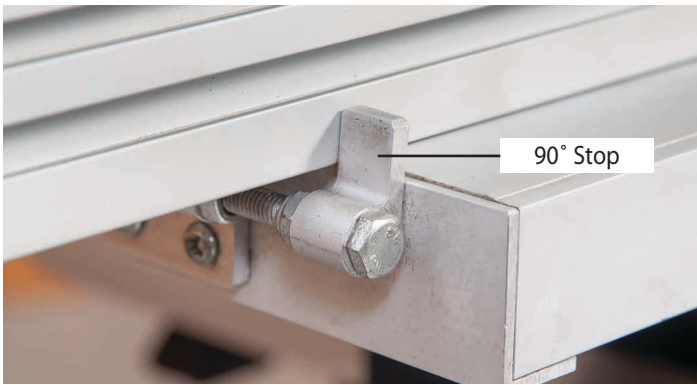
Fig 63



11. Loosen the butterfly knobs on the mitre casting (24), insert the 'T' bolts into the fence's 'T' slot rail (29). Lift-up the 90° stop located in the corners of the sliding table (28) and push the fence up against the stop, see fig 64-65.

Fig 64-65-66-67

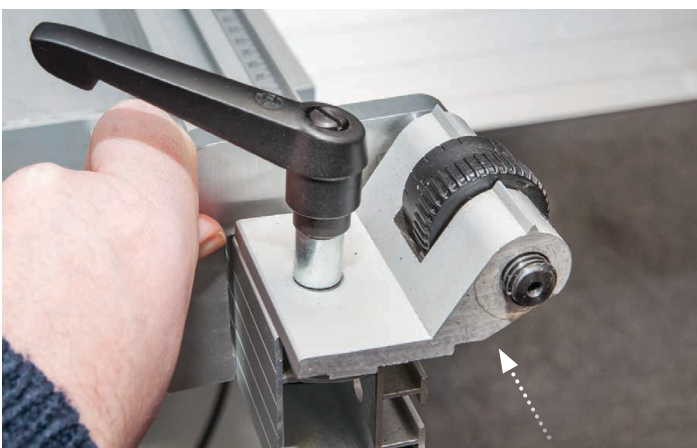




12. Slide the fence (29) near the blade but not touching, tighten the butterfly knobs, see fig 66-67. **Note: check that the fence does not come into contact with the riving knife.**

13. Locate the fence distance stop (27). Loosen the clamping handle, slide the assembly into the 'T' slot to the opposite end of the fence (29) and secure in place, see fig 68-69.

Fig 68-69



14. Using a 90° square check that the blade is at 90° to the fence assembly (29) and make adjustments until correct, see fig 70.

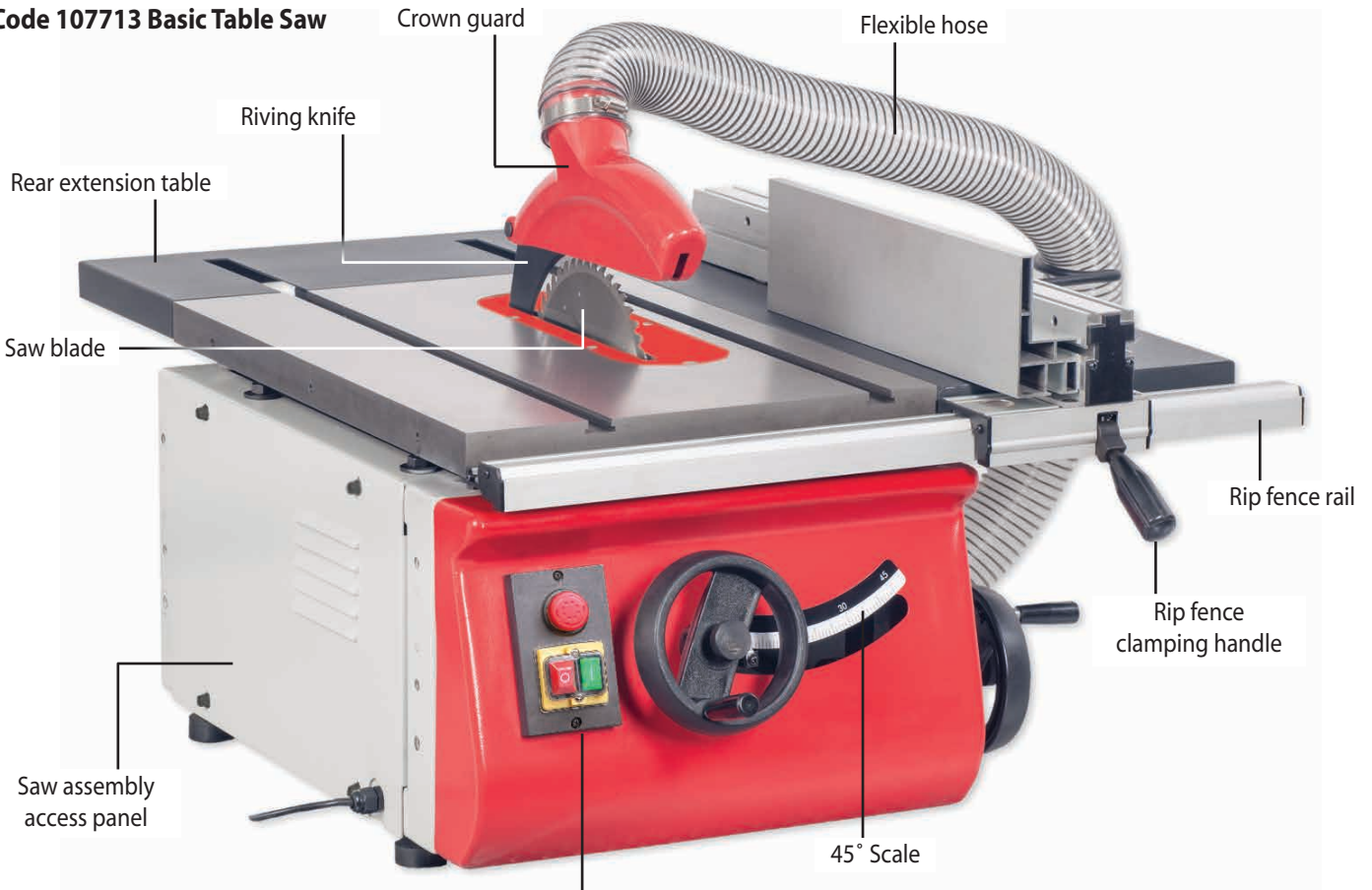
Fig 70



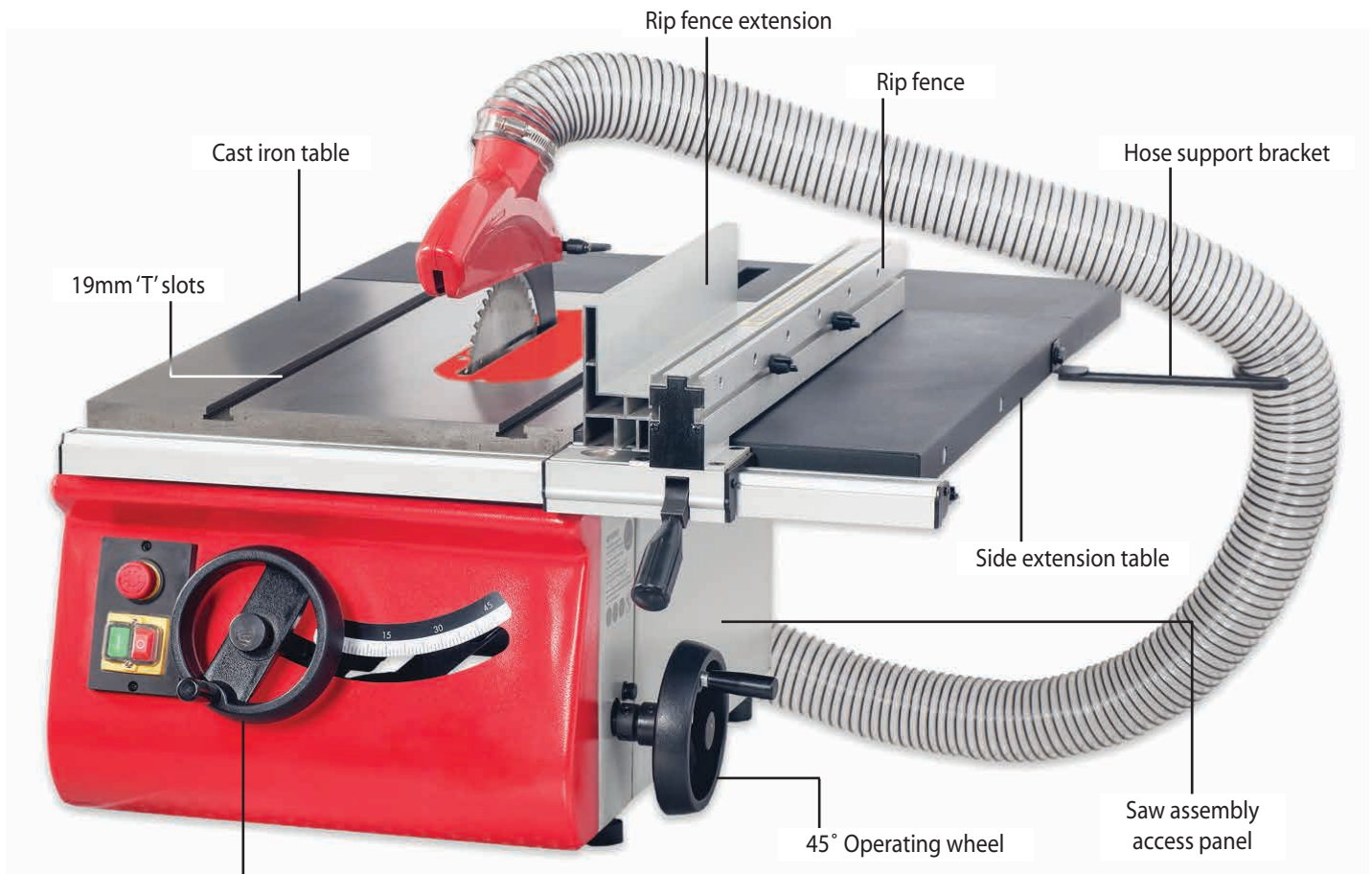
ILLUSTRATION AND PARTS DESCRIPTION

Code 107712 Basic Table Saw

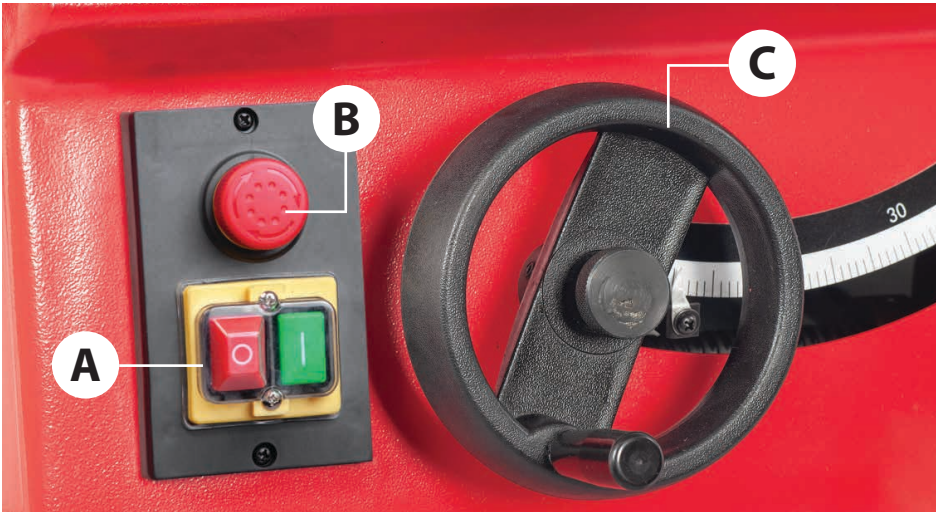
Code 107713 Basic Table Saw



Main Table Saw



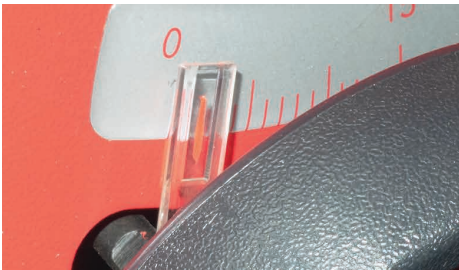
Rise & fall operating handle



ON/OFF control switch (A), Emergency stop button (B)
Rise and Fall operating wheel (C)



Optional 104928 Mitre Fence



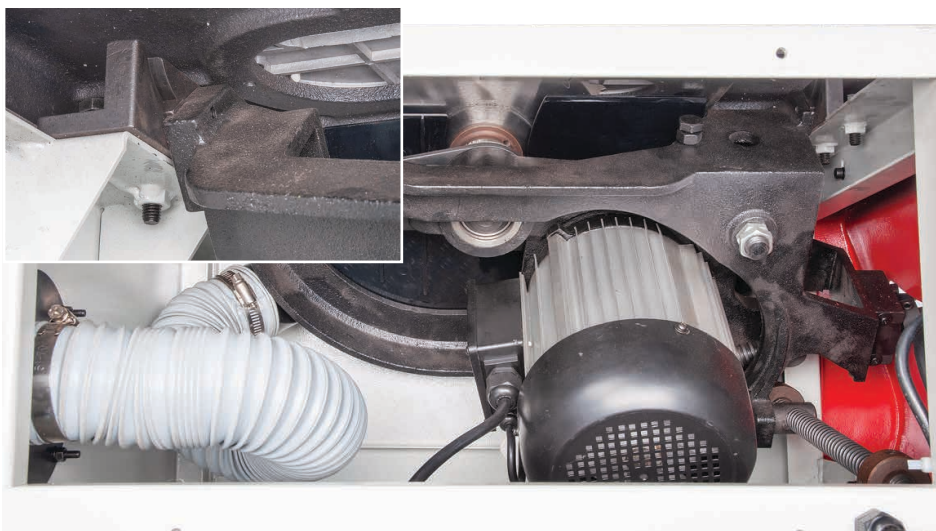
Tilt scale pointer and adjusting screw



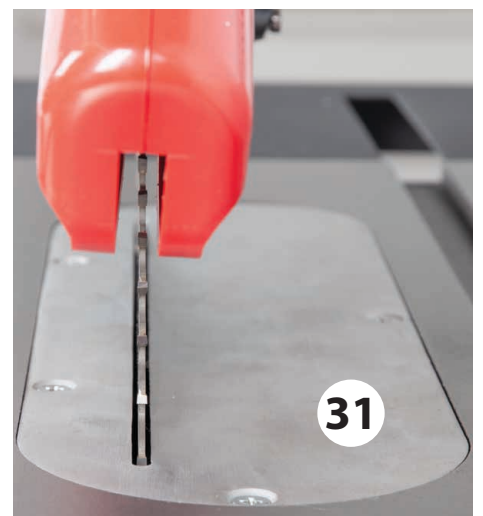
100mm Dust extraction moulding



Rip fence magnifying glass
and index marker



Motor and saw assembly



Optional 104933 insert gives
better material support for
cutting thin strips

ILLUSTRATION AND PARTS DESCRIPTION

Table Saw Optional Accessories



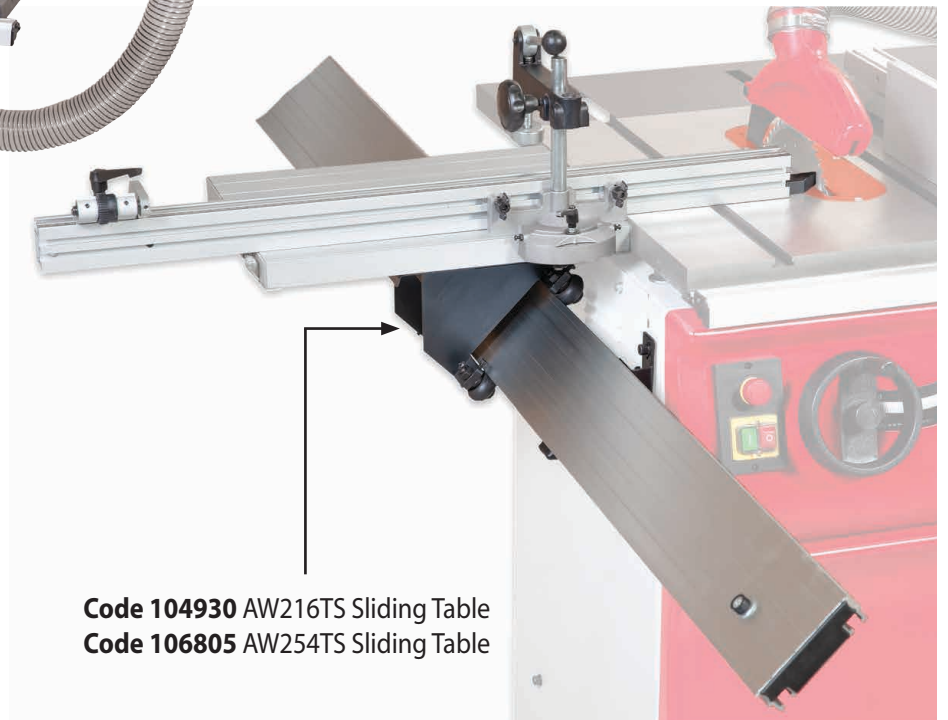
Code 104931 AW216TS Floor Stand
Code 106804 AW254TS Floor Stand



Code 106808 AW216TS Left Hand Extension Table
Code 106809 AW254TS Left Hand Extension Table



Code 104932 AW216TS Cabinet Stand
Code 106806 AW254TS Cabinet Stand

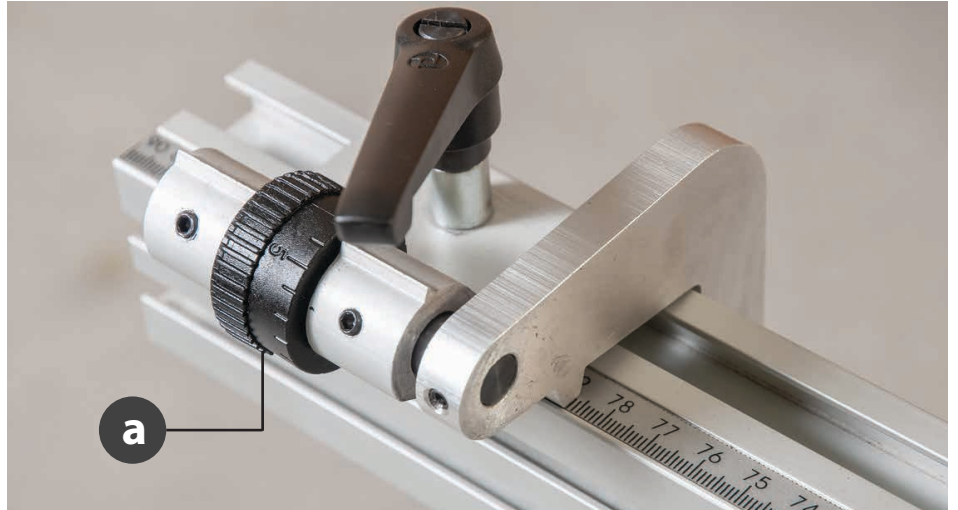


Code 104930 AW216TS Sliding Table
Code 106805 AW254TS Sliding Table

ILLUSTRATION AND PARTS DESCRIPTION



Cabinet stand storage door



Distance stop (27) with micro adjusting wheel (a)



Fence mitre scale, pointer and clamping handle



Fence mitre adjusting screw stops for -45° to $+45^{\circ}$

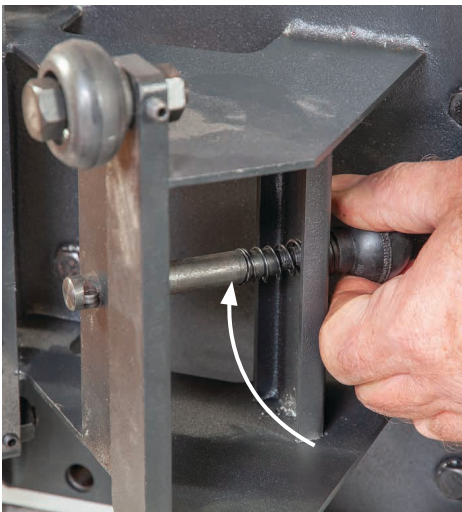
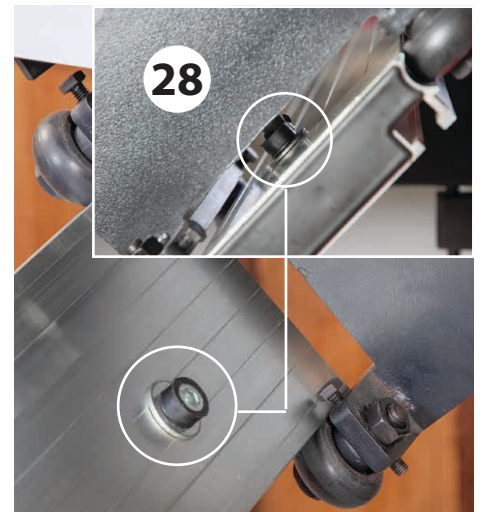


Table stop pin knob, engage to prevent the table from sliding off the carriage assembly



Hold down clamp assembly



Sliding carriage stop, prevents the sliding table from coming off the carriage

SET UP AND ADJUSTMENT

The Riving Knife

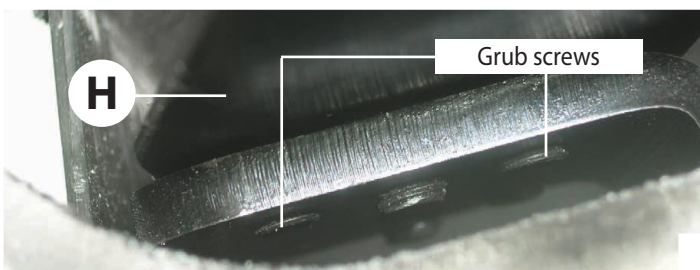
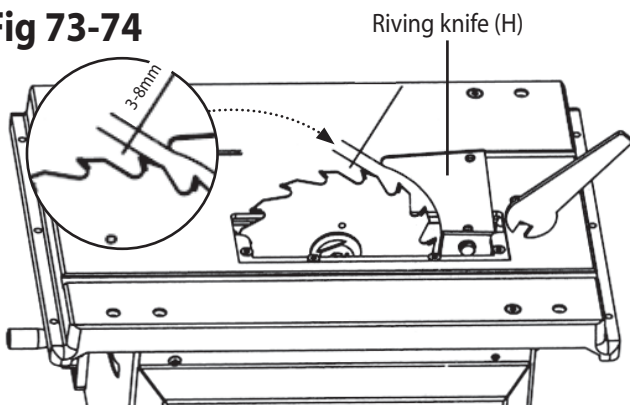
1. Raise the saw blade to its highest point and remove the saw blade crown guard (K) and the table insert, place safely aside, see fig 71-72.

Fig 71-72



2. Using the spanner loosen the riving knife (H) and check that the tip of the knife has a clearance of 3-8mm between the blade. Adjust the four grub screws to the opposite side of the clamping plate to align the riving knife with the blade. Tighten the nuts to secure the riving knife in place. **NOTE: Check that the riving knife is parallel to the saw blade by placing the fence up against them**, see fig 73-74.

Fig 73-74



Setting the Rip Fence & Scale

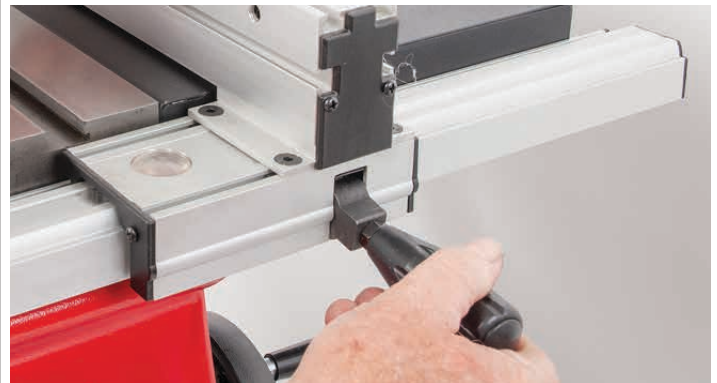
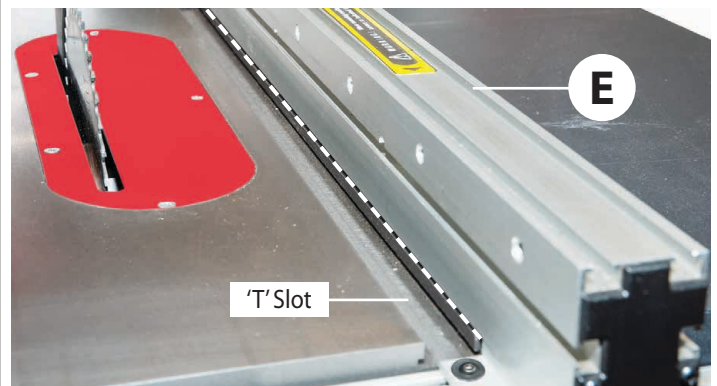


MAKESURE THE BLADE IS SQUARE TO THE TABLE AND THE FENCE IS SQUARE TO THE BLADE!

The fence scale does not come pre-mounted to the fence rail and needs to be stuck in place. **NOTE: Before sticking the scale down make sure the table and fence assembly is square to the blade. Follow the instruction below.**

1. Remove the crown guard (K) and rip fence extension (F) and 'T' bolts and place safely aside. Line up the fence (E) with the edge of the tables 'T' slot and press down the locking handle, see fig 75-76.

Fig 75-76



2. Check the fence is parallel with the 'T' slot, if adjustment is required loosen the four Hex screws on either side of the fence assembly and adjust the fence until it's in line, see fig 77, re-tighten the Hex screws.

Fig 77



Fig 78



3. Place the fence assembly up against the blade and lock in place, see fig 78.

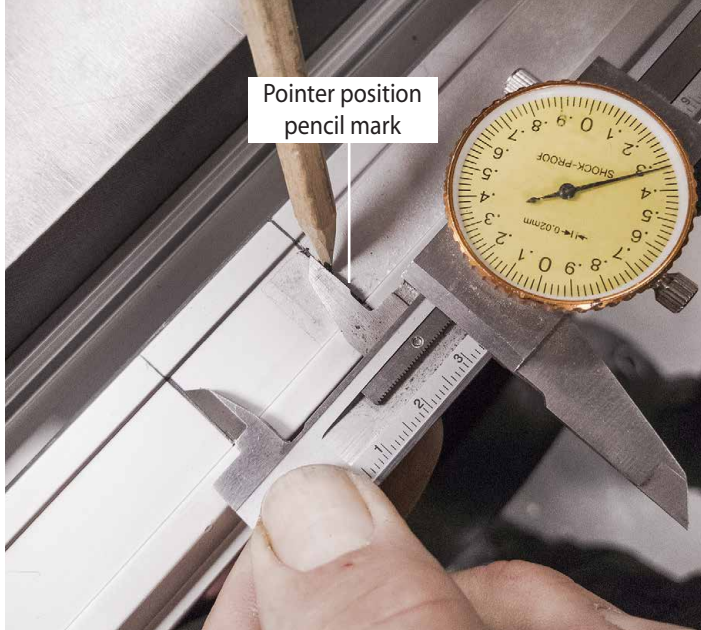
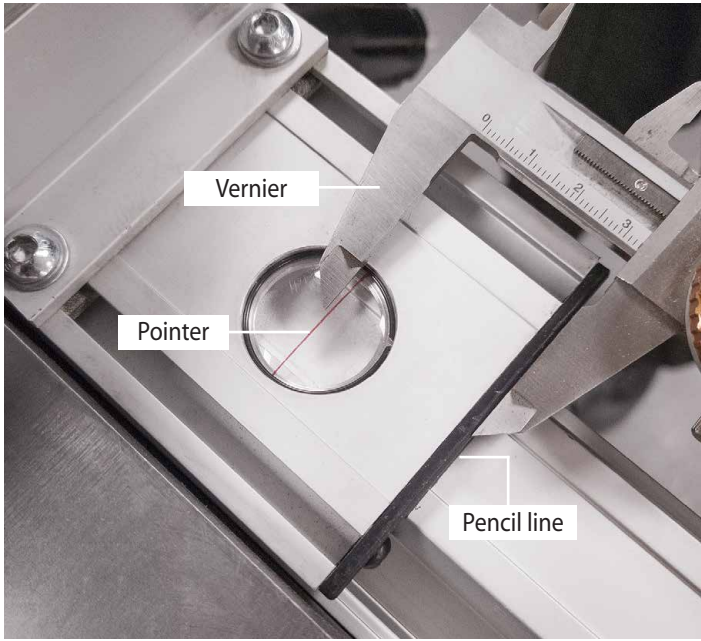
4. Using a pencil draw a line on the fence rail to mark the position, see fig 79.

Fig 79



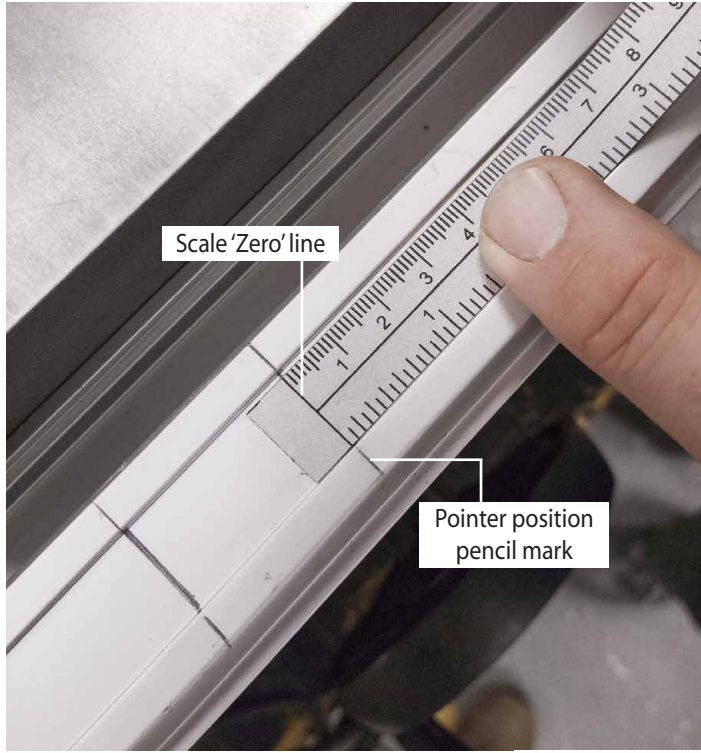
5. Use a steel rule or vernier measure the distance between the pointer & pencil line, remove the fence assembly & mark the second position on the fence rail, see figs 80-81-82.

Fig 80-81-82



6. Locate the scale strip and peel off the backing, line-up the scale's 'Zero' line with pencil line's pointer and carefully stick down the scale strip, see 83-84.

Fig 83-84



SET UP AND ADJUSTMENT



7. Trim any excess material from the end of the fence rail, see fig 85.

Fig 85



8. Replace the fence assembly and place against the blade. The magnifying glass pointer should read 'Zero' on the fence rail scale, see fig 86-87.

Fig 86-87-88



Magnifying Glass Pointer
set to 'ZERO'

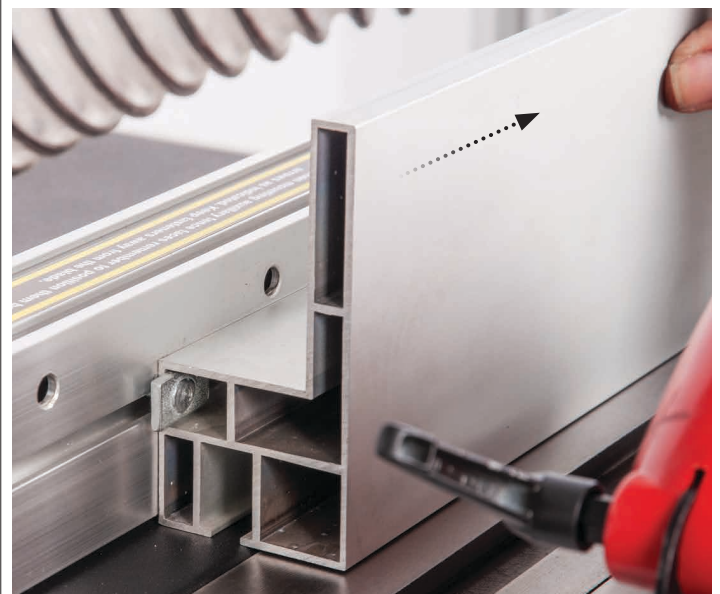


'Zero' pointer

Rip Fence Extension

The rip fence extension can be repositioned from the vertical to a horizontal position for guiding thin pieces through. Loosen the two butterfly knobs holding the fence extension, remove, lay the fence extension down in the horizontal position and remount the fence extension as before, see fig 89-90. Move the extension down until the end face is centred with the blade and tighten the two butterfly knobs.

Fig 89-90

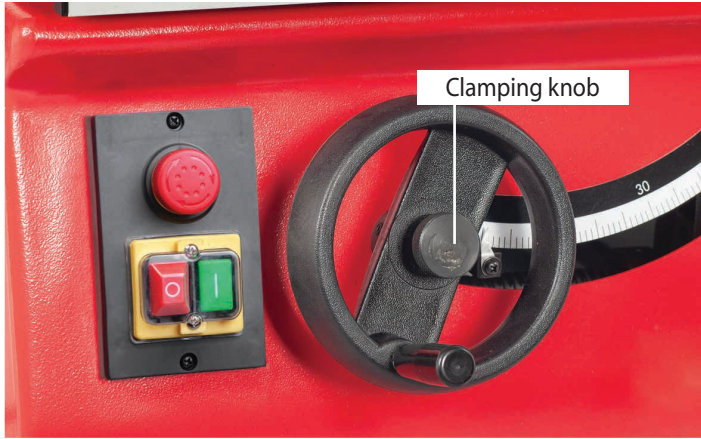




Adjusting the Cutting Height

Release the clamping knob, adjust the blade height with the rise and fall operating wheel, see fig 91, so that the blade teeth are protruding through the work piece.

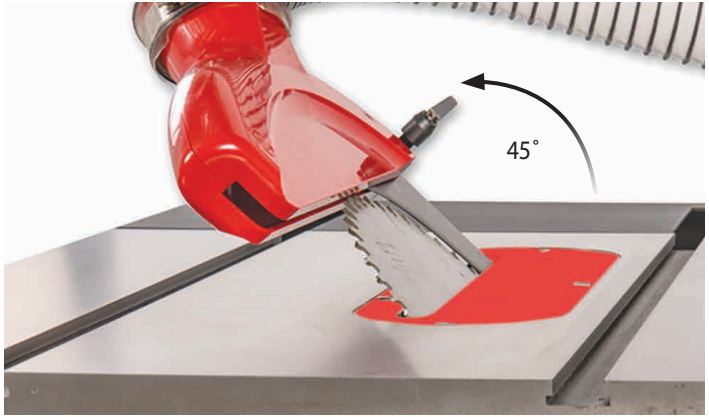
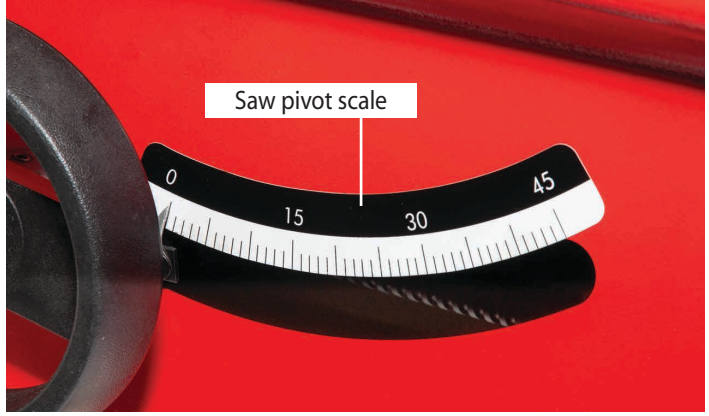
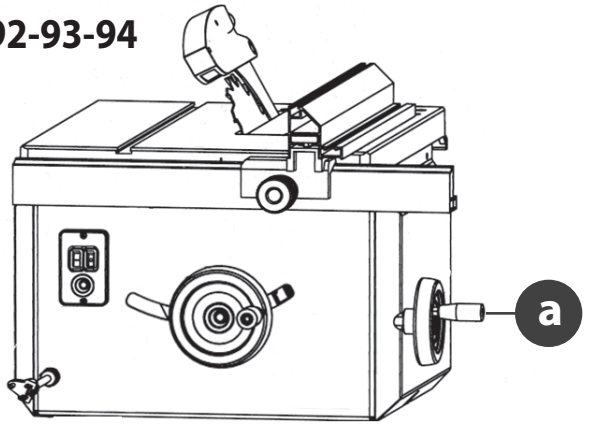
Fig 91



Adjusting the Pivot

Release the locking knob to the centre of the operating wheel (a) to the side of the saw assembly and turn clockwise to pivot the saw to a maximum of 45° degrees, indicated on the scale, see fig 92-93-94.

Fig 92-93-94



OPERATING INSTRUCTIONS



NOTE: BEFORE USING YOUR SAW, GO ROUND AND MAKE SURE EVERYTHING IS SECURE, FASTENED DOWN, THAT ALL TOOLS ARE CLEARED AWAY FROM THE WORK AREA!



CHECK: THE BLADE FOR SHARPNESS, MISSING TEETH, RESIN BUILD UP ETC., CLEAN IF NECESSARY. CHECK THE BLADE IS SECURELY CLAMPED IN PLACE (I.E. NOT LOOSE)!



CONNECT A DUST EXTRACTION MACHINE TO THE SAW.



UNDER NO CIRCUMSTANCES SHOULD CHILDREN BE ALLOWED IN THE WORK AREA AND KEEP TOOLS AND EQUIPMENT OUT OF REACH OF YOUNG CHILDREN!



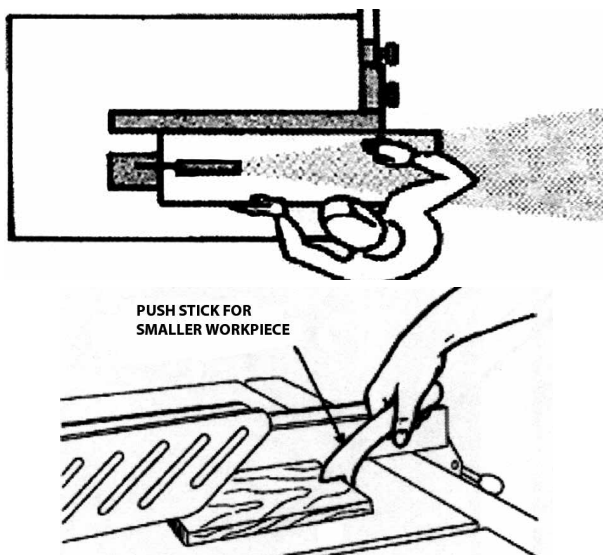
CONNECT THE SAW TO THE MAINS SUPPLY!

Give the machine a 'quick' burst check (i.e. quick ON-OFF) to ensure everything is O.K. If everything is satisfactory, the table saw is ready for use.

Feeding the Work by Hand

Start up the saw, wait until it has reached full speed and slowly feed the timber through using both handles, (making sure to keep your hands well clear of the blade and using a push stick for small pieces), until the timber is behind the riving knife. Switch off the saw, wait until the blade has come to a complete stop and remove the timber, see fig 95-96-97.

Fig 95-96-97



N



NOTE: Secure larger pieces of timber to the table by using the hold down clamp.

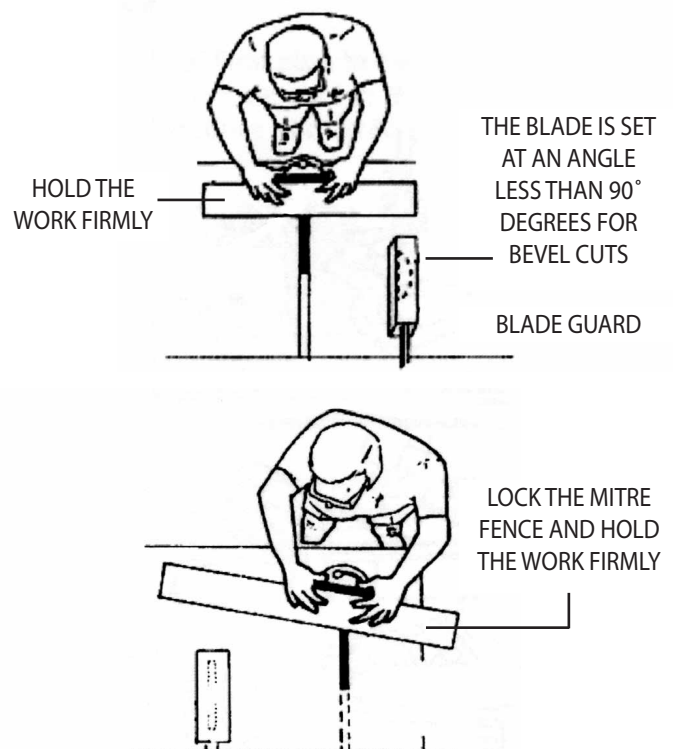
Cutting Narrow Pieces

Use the small flat surface of the rip fence extension (F) to cut thin timber narrower than 120mm, note: use a push stick.

The Optional Mitre Fence

The mitre fence (32) can be mounted on either side of the saw blade in the two 19mm 'T' slots, pre machined into the cast iron table. The mitre fence can be angled from 90° to 45° degrees, see fig 98-99-100.

Fig 98-99-100

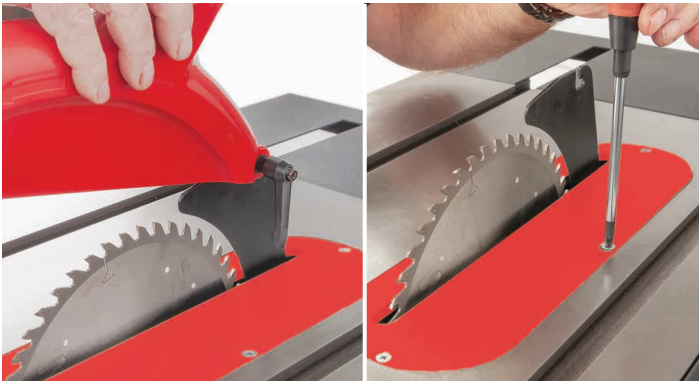




DISCONNECT THE MACHINE FROM THE MAINS SUPPLY!

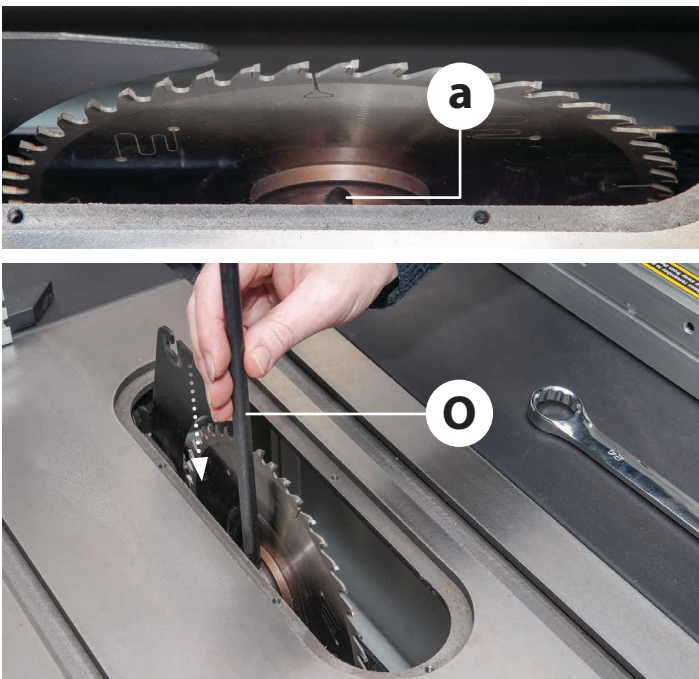
1. Raise the saw blade to its highest point, remove the saw blade crown guard, remove the five cross head screws that secure the table insert, place carefully aside and remove the table insert, see fig 101-102.

Fig 101-102



2. Turn the saw until the locking bar hole (a) is visible and insert the blade locking bar (O) into the hole, see fig 103-104.

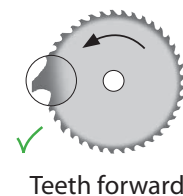
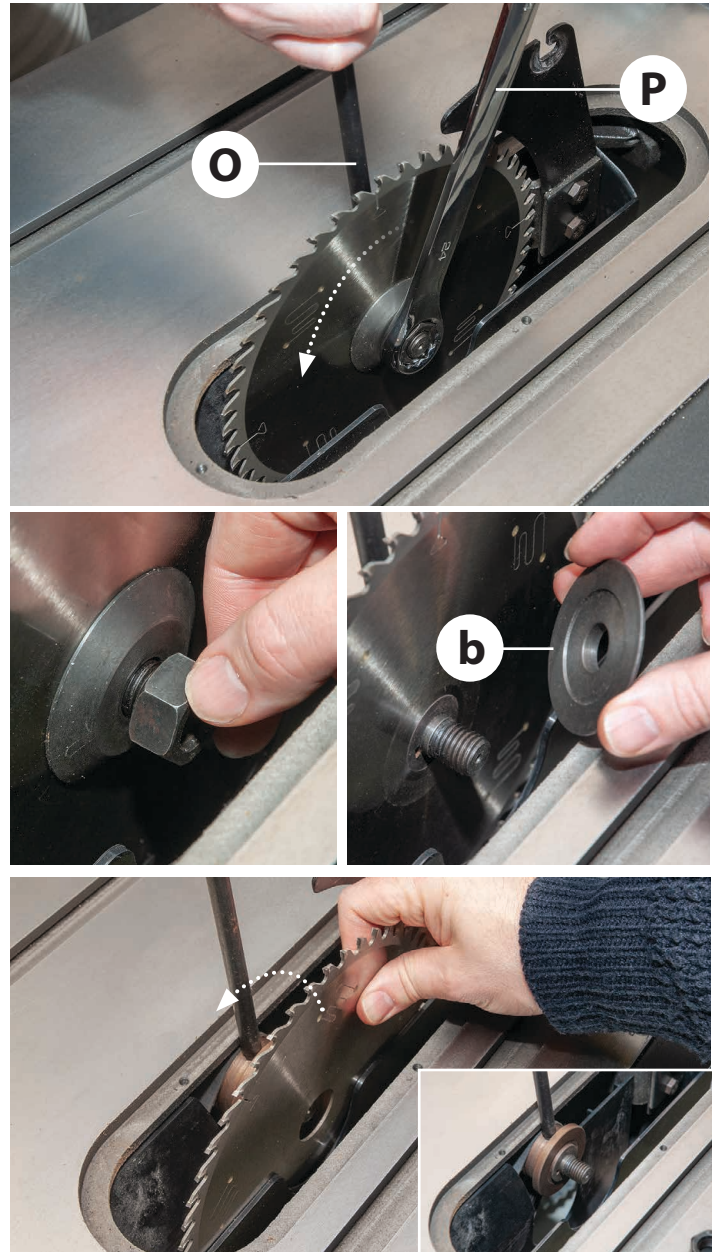
Fig 103-104



3. Hold the locking bar (O) undo and remove the nut using the 24mm spanner (P), see fig 105-106. Remove the saw plate washer (b) and the saw blade and place to one side, see fig 107-108.

4. Give the interior of the machine, the dust extraction channels, etc. a thorough clean. Check the new blade for damage, missing teeth, sharpness etc. Fit the new blade, ensure that the teeth are pointing towards the front of the machine. Put the saw plate washer onto the shaft and replace the 'Nut'

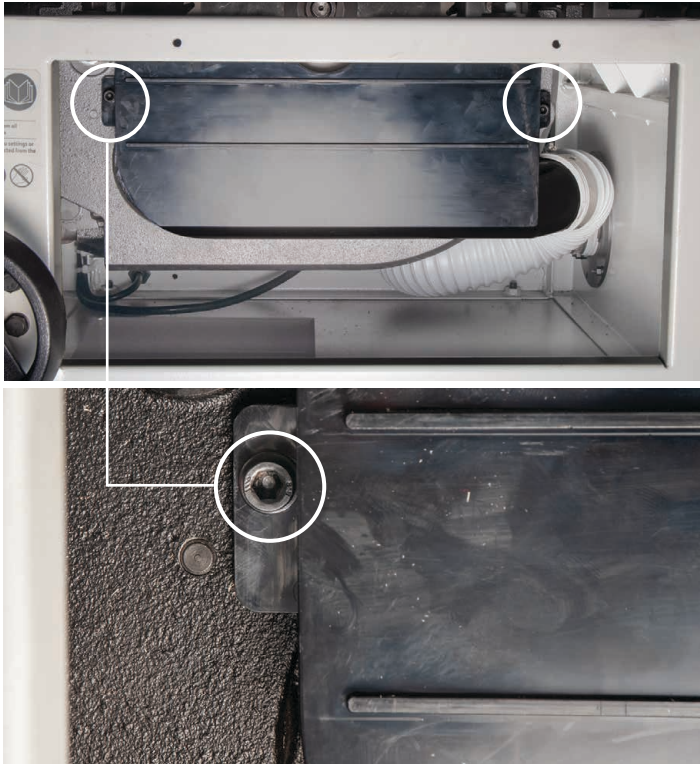
Fig 105-106-107-108



until finger tight and check the saw is correctly seated.
5. Tighten up the 'Nut', using the blade locking bar (O) to hold the shaft steady. Check the riving knife is aligned with the saw blade, and correctly positioned. Replace the table insert and secure with the cross head screws. Replace the crown guard. When everything is satisfactory, turn the saw blade once by hand to check it doesn't foul anywhere.

6. Reconnect the machine to the mains supply. Give the machine a 'quick' burst (i.e. quick ON-OFF) check to ensure everything is O.K. If everything is satisfactory, continue to use the machine.

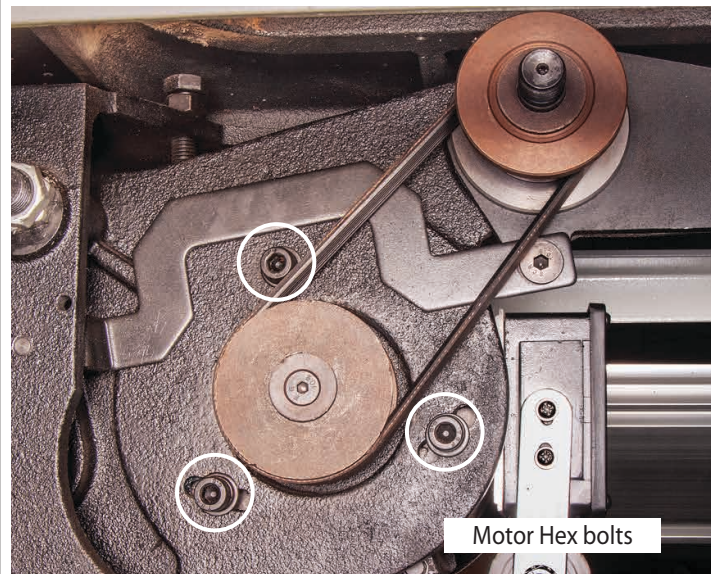
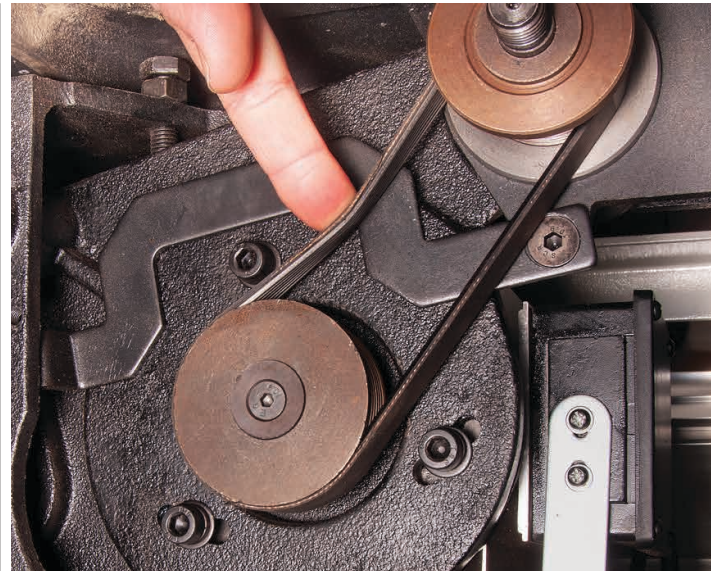
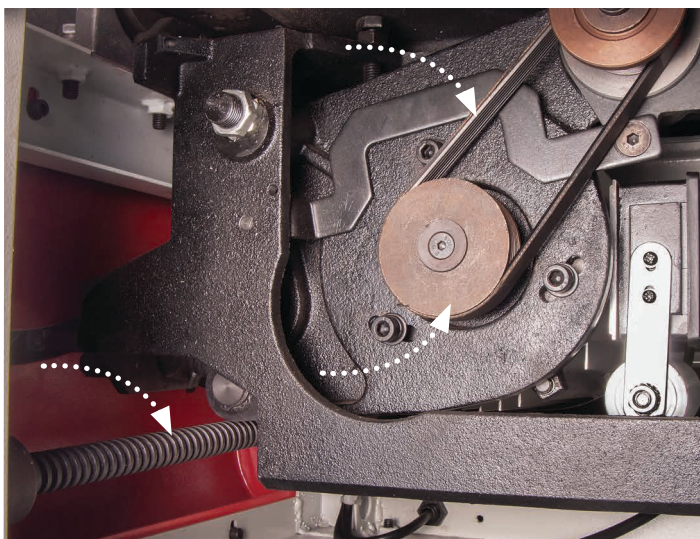
Fig 109-110



1. Keep the saw as clean and free from saw dust build up as is practical. Periodically, remove the saw gullet by removing the side access panel to the side of the machine and undo the two Hex screws on either side of the gullet, see fig 109-110. Vacuum out and clean out the saw box and the extraction housing. Remove any resin build up in the saw box, using a proprietary resin cleaner.

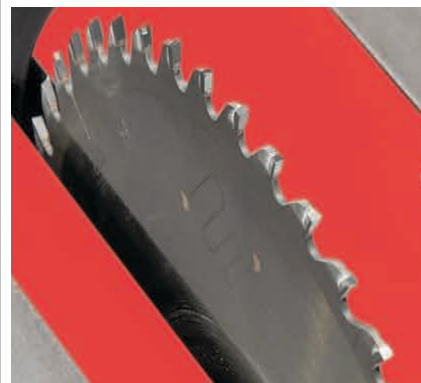
2. Clean the threaded drive shafts of the rise and fall and tilt mechanisms, see fig 111. At the same time check the belt drive, i.e. the belt is not 'glazing' with resin build up, likewise with the pulley wheels. Check the belt tension, see fig 112. If the belt is becoming slack, loosen the motor Hex bolts and push the motor down, see fig 113. Re-tighten the Hex bolts.

Fig 111-112-113



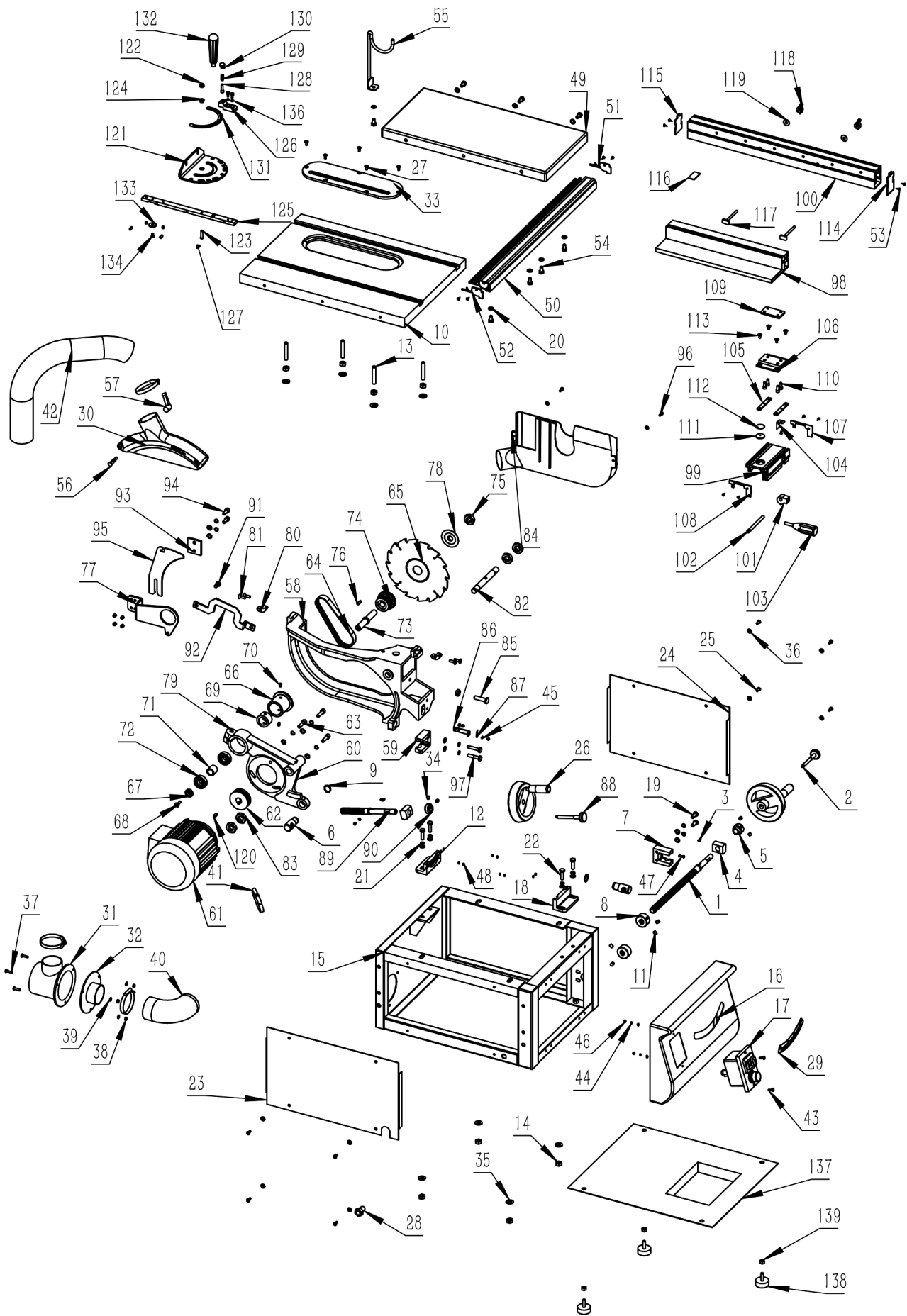
3. Check the saw blade regularly for chipped, missing, damaged teeth etc. and remove any resin build up from the blade, riving knife etc, see fig 114.

Fig 114



4. If you have finished using the saw bench, clean above and below the work table, wipe the saw bench over. If the saw is not going to be used for a period of time, use 'Ambersil Dry PTFE Film Antistick', spray, code 952137 over the work table, blade, tilt and rise and fall screw threads and place a dust sheet over the saw bench.

107712 AW216TS Basic Table Saw Diagram A

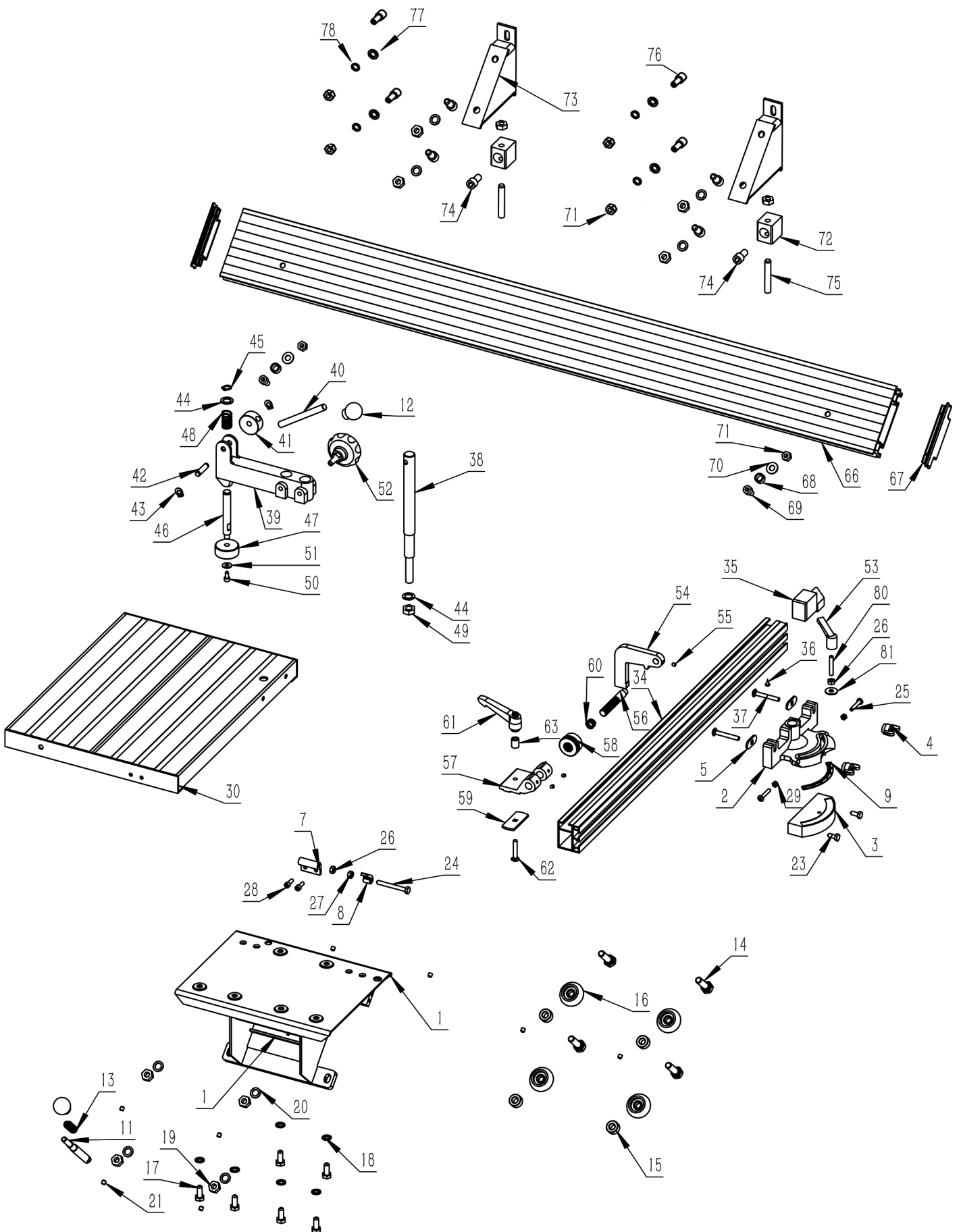


EXPLODED DIAGRAMS/LISTS

107712 AW216TS Basic Table Saw Diagram A

No.	Description	No.	Description	No.	Description
1	Adjusting Thread Rod	50	Front Rail	100	Rip Fence
2	Locking Knob	51	Right End Captor Front Rail	101	Eccentric Wheel
3	Semi-circle key 3x16	52	Left End Captor Front Rail	102	Locking Shaft
4	Angel Connection Knob	53	Taping Screw ST4.2 x 10	103	Locking Knob
5	Stop A	54	Hex.Bolt M8 x 16	104	Locking Spring Plate
6	Nut of Adjusting Thread Rod	55	Tube Support	105	Locking Nut Board
7	Mounting Seat	56	Locking Guard Guard	106	Fence Plate
8	Stop Collar	57	Adjusting Handle	107	Right End Cap for Rail Housing
9	Cir-clips for Shaft D=20	58	Rotating Bracket	108	Left End Cap for Rail Housing
10	Worktable	59	Housing Knob	109	Screw Guide
11	Hex.Socket Set Screw M8 x 10	60	Shaft Base	110	Hex.Socket Cap Head Bolt M6 x 16
12	Mounting Base A	61	Motor	111	Scale Indicator
13	Hex.Socket Set Screw with Flat Point M10 x 50	62	Motor Pulley	112	Circle Ring
14	Hex.Nut M10	63	Hex.Socket Cap Head Bolt M8 x 30	113	Hex.Socket Bolt M6 x 12
15	Machine body	64	Multi-Grooves Belt	114	Front End Cap for Fence
16	Front Panel	65	Saw Blade	115	Rear End Cap for Fence
17	Switch	66	Saw Blade Sleeve	116	Supporting Plate
18	Mounting Base B	67	End Bush of Arbor Shaft	117	Locking Screw
19	Hex.Bolt M8 x 20	68	Cross Recessed Socket Screw M6 x 20	118	Wing Nut
20	Flat Washer 8mm	69	Arbor Shaft Bush	119	Big Washer 6mm
21	Spring Washer 8mm	70	Spring Pin 6	120	Key 6 x 20
22	Hex.bolt M8 x 30	71	Arbor Shaft Bush	121	Mitre Gauge Base
23	Left Panel	72	Bearing 6203	122	Self-Locking Nut M6
24	Right Panel	73	Arbor Shaft	123	Hex.Pan Head Bolt M6 x 20
25	Cross Recessed Pan Head Screw M6 x 12	74	Blade Pulley	124	Bush
26	Handwheel	75	Nut M16	125	Mitre Gauge Guide Rod
27	Cross Recessed Socket Screw M5 x 12	76	Flat Key 5 x 20	126	Block Indicator
28	Cablegland M14	77	Riving Knife Bracket	127	Set Screw M6 x 12
29	Rotating Scale	78	Outer Blade Washer	128	Stop Pin
30	Blade Guard	79	Hex.Socket Cap Head Bolt M10 x 30	129	Stop Spring
31	Tie-in B	80	Rotating Block	130	Brass Knob
32	Tie-in A	81	Cross Recessed Socket Screw M6 x 15	131	Scale / Gauge
33	Table Insert	82	Shaft	132	Mitre Gauge Knob
34	Hex.Socket Set Screw M8 x 8	83	Thin Nut M16 x 1.5	133	Washer
35	Flat Washer 10mm	84	Dust Collection Cover	134	Cross Recessed Socket Screw M5 x 10
36	Flat Washer 6mm	85	Hex.Bolt M10 x 40	135	Hex.Socket Set Screw M6 x 6
37	Cross Recessed Pan Head Screw M5 x 20	86	Pointer Block	136	Spring Washer
38	Hex.Nut M5	87	Pointer	137	Bottom Panel
39	Flat Washer 5mm	88	Locking Knob	138	Levelling Foot
40	Dust Collection Tube Inside the Machine	89	Height Adjusting Thread Rod	139	Hex.Nut M8
41	Neck Chain	90	Stop Collar B		
42	Dust Collection Tube	91	Pull-Rod Shaft		
43	Cross Recessed Pan Head Screw M4 x 15	92	Connection Rod of Riving Knife Bracket		
44	Spring Washer 4mm	93	Pressing Plate of Riving Knife		
45	Flat Washer 4mm	94	Hex.Socket Cap Head Bolt M8 x 20		
46	Hex.Nut M4	95	Riving Knife		
47	Cross Recessed Pan Head Screw M4 x 6	96	Hex.Socket Cap Head Bolt M5 x 12		
48	Hex.Socket Set Screw M4 x 5	97	Hex.Bolt M8 x 40		
49	Extension Table	98	L shape Fence		
		99	Scale Rail Housing		

104930 AW216TS Optional Sliding Table Kit Diagram B



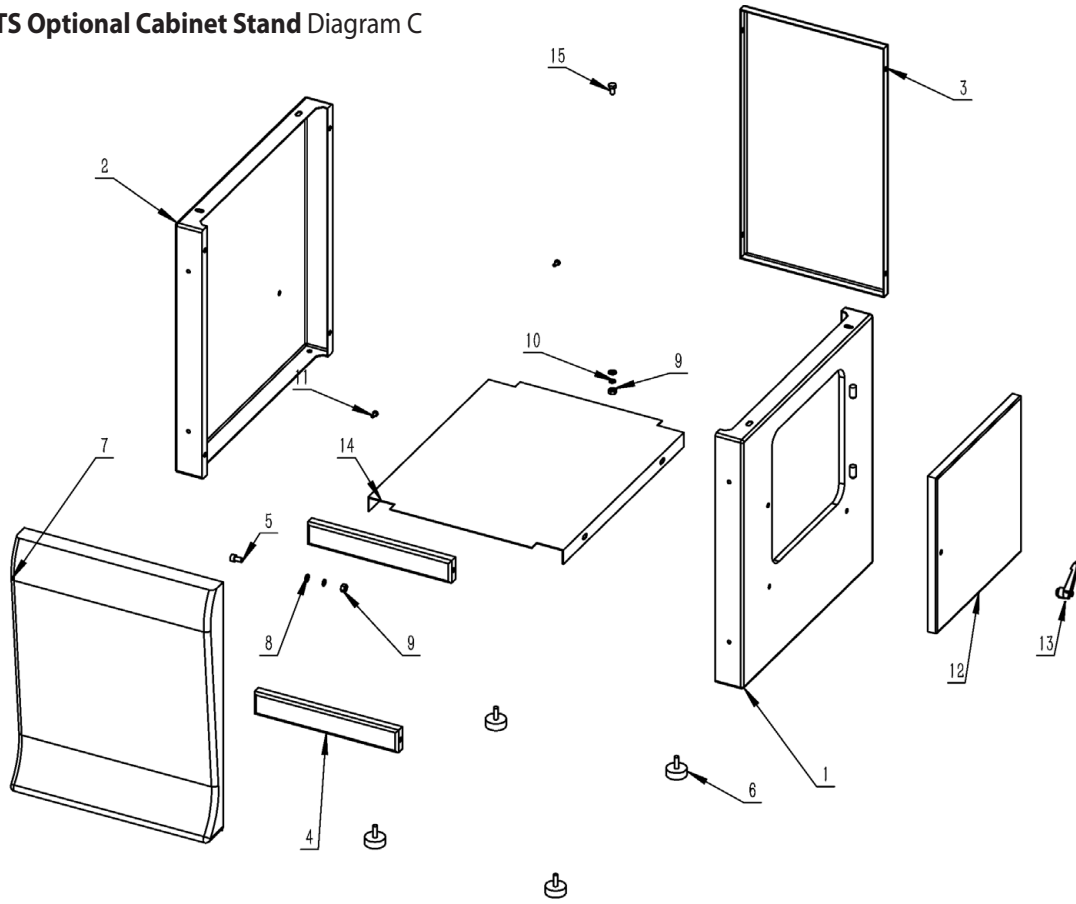
EXPLODED DIAGRAMS/LISTS

104930 AW216TS Optional Sliding Table Kit Diagram B

No.	Description
1	Mounting Bracket
2	Mitre Guage
3	Scale Mount
4	Wing Nut
5	Bolt Guide
7	Locating Bracket
8	Locating Plate
9	Scale
11	Stop Shaft
12	Knob-Lever
13	Spring Stop Shaft
14	Shaft Roller Wheel
15	Bush Roller Wheel
16	Roller Wheel
17	Hex.Bolt M8 x 20
18	Teeth shape washer 8mm
19	Hex.Nut M10
20	Washer 10mm
21	Hex. Socket Set sSrew M6 x 6
23	Hex.Bolt M6 x 15
24	Hex.Bolt M6 x 55
25	Cross Recessed Pan Head Screw M5 x 30
26	Hex.Nut M6
27	Self-Locking Nut M6
29	Hex.Nut M5
30	Sliding Table
34	Cross Cut Fence
35	End Cap Cross Cut Fence
36	Taping Screw ST4.2 x 10
37	Step Bolt
38	Stud Hold Down
39	Arm Hold Down
40	Handle Hold Down
41	Eccentric Hold Down
42	Pin Hold Down
43	Cir-Clips for Shaft 8mm

44	Washer 12mm
45	Cir-Clips for Shaft 12mm
46	Stud Hold Down
47	Disc Hold Down
48	Spring Hold Down
49	Hex.Nut M12
50	Hex. Socket Cap Head Bolt M5 x 12
51	Washer 5mm
52	Star-Type Knob Hold Down
53	Ratchet Lever
54	Flip Stop
55	Hex.Socket Set Screw M5 x 5
56	Stud Hold Down
57	Flip Stop Base
58	Knurled Knob
59	Screw Guide
60	Spring Flip Stop
61	Ratchet Lever Flip Stop
62	Step Bolt M6 x 35
63	Spacer Ratchet Lever
66	Sliding Rail
67	End cap,sliding rail
68	Rubber Bush
69	Hex. Socket Cap Head Bolt M8 x 16
70	Washer 8mm
71	Hex.Nut M8
72	Carriage
73	Carriage Sliding Rail
74	Hex. Socket Cap Head Bolt M10 x 20
75	Flat end set screw M10 x 50
76	Treaded Adjuster
77	Washer 8mm
78	Spring Washer 8mm
79	Hex.Socket Set Screw M8 x 15
80	Hex.Socket Set Screw M6 x 35
81	Washer 6mm

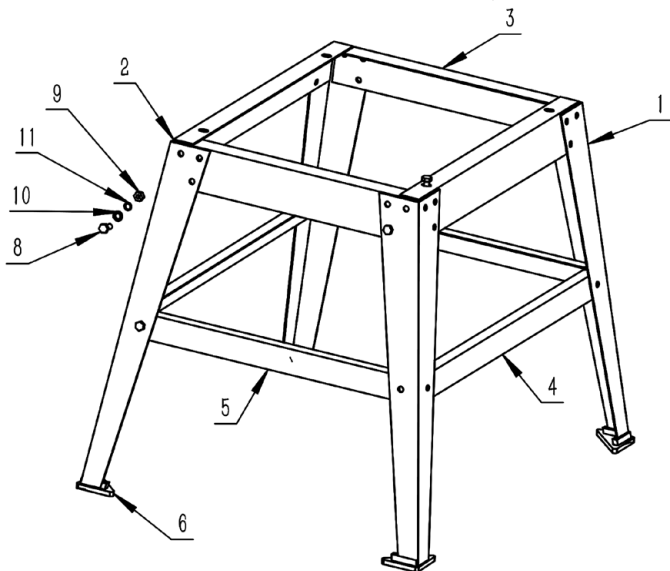
104932 AW216TS Optional Cabinet Stand Diagram C



No.	Description
1	Right Panel,Cabinet Stand
2	Left Panel,Cabinet Stand
3	Rear Panel,Cabinet Stand
4	Sidelong Support Front Panel
5	Hex. Socket Cap Head Bolt M8 x 16
6	Levelling Foot
7	Front Panel, Cabinet Stand

8	Washer 8mm
9	Hex.Nut M8
10	Spring Washer 8
11	Cross Recessed Pan Head Screw M6 x 12
12	Access Door, Cabinet Stand
13	Ratchet Lever
14	Internal Shelf
15	Hex.Bolt M8 x 16

104931 AW216TS Optional Floor Stand Diagram D



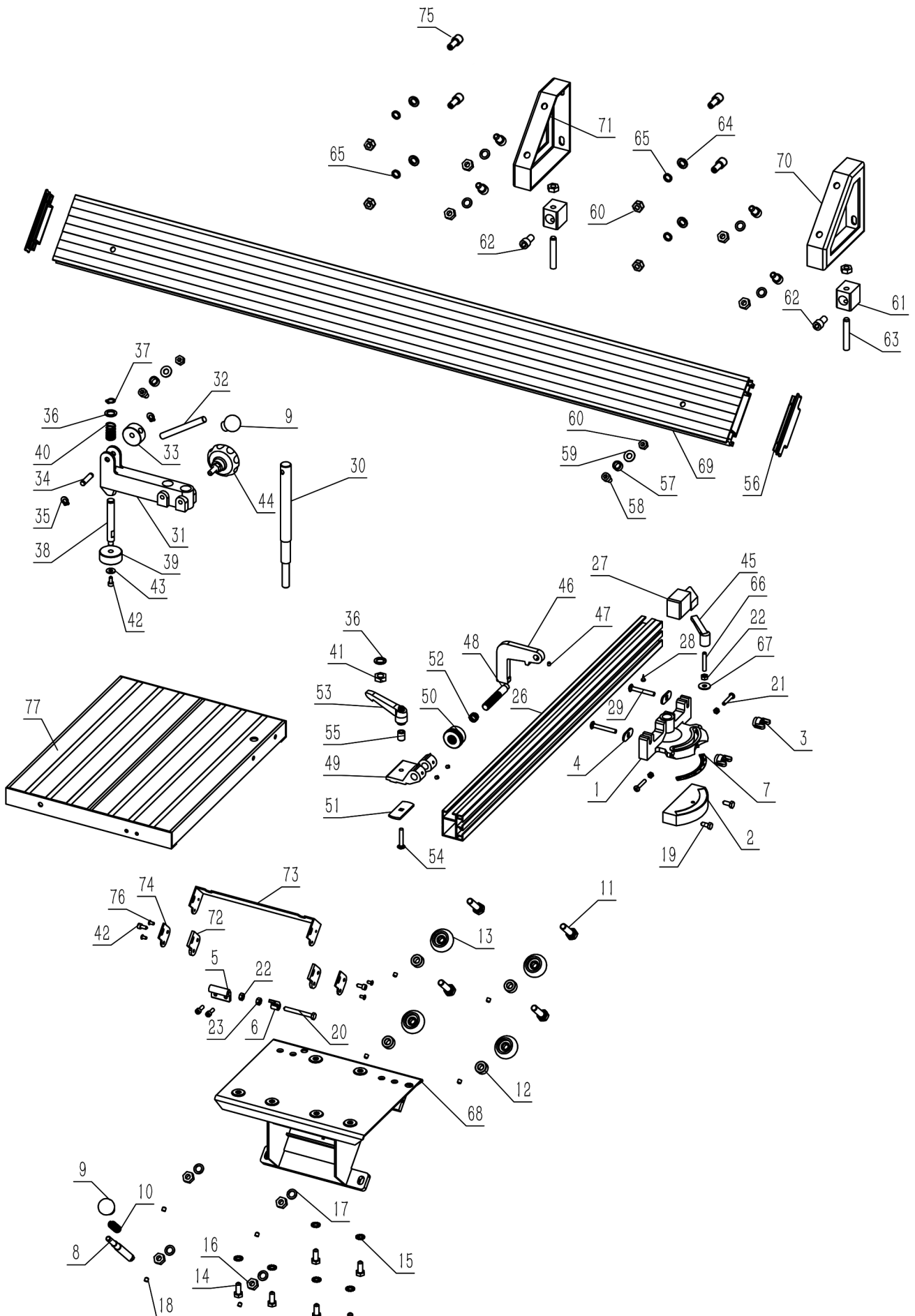
No.	Description
1	Stand Leg
2	Upper Long Bracket Stand Leg
3	Upper Short Bracket Stand Leg
4	Lower Long Bracket Stand Leg
5	Lower Short Bracket Stand Leg
6	Levelling Foot
8	Hex.Bolt M8 x 20
9	Hex.Nut M8
10	Washer 8mm
11	Spring Washer 8mm

107713 AW254TS Basic Table Saw Diagram A

No.	Description	44	Bottom Panel	88	Hex.Bolt M8 x 20
1	Motor Pulley	45	Switch	89	Hex.Nut M10
2	Pulley	46	Pointer Block	90	Levelling Foot
3	Motor	47	Washer 6mm	91	Cross Recessed Pan Head Screw M6 x 12
4	Shaft Base	48	Blade Guard	92	Front Rail
5	Saw Blade Sleeve	49	Riving Knife	93	Left End Cap Front Rail
6	Arbor Shaft Bush	50	Motor Shaft	94	Right End Cap Front Rail
7	End Bush of Arbor Shaft	51	Thin Nut M16 x1.5	95	Scale Front Rail
8	Arbor Shaft	52	Stop B	96	Taping Screw ST4.2 x 10
9	Bearing 6203	53	Locking Knob B	97	Rip Fence
10	Outer Blade Washer	54	Tube Support	98	Front End Cap Rip Fence
11	Arbor Shaft Bush	55	Rear Extension Table	99	Screw Guide
12	Hex.Socket Cap Head Bolt M8 x 30	56	Step Screw	100	Rear End Cap Rip Fence
13	Washer 8	57	Big Washer 10	101	Scale Rail Housing
14	Spring Washer 8	58	Height Adjusting Gear	102	Locking Nut Board
15	Cross Recessed Socket Screw M6 x 20	59	Mounting Base A	103	Hex.Socket Cap Head Bolt M6 x 16
16	Hex.Socket Cap Head Bolt M10 x 30	60	Mounting Base B	104	Locking Spring Plate
17	Multi-Groove Belt	61	Pressing Plate Riving Knife	105	Locking Knob
18	Saw Blade	62	Washer 10	106	Eccentric Wheel
19	M16 Nut	63	Hex.Recessed Socket Screw M8 x 20	107	Locking Shaft
20	Rotating Bracket	64	Pull-Rod Shaft	108	Scale Indicator
21	Connection Rod of Riving Knife	65	Hex.Recessed Socket Screw M6 x 15	109	Left End Cap Scale Rail Housing
22	Riving Knife Bracket	66	Motor Pad	110	Right End Cap Scale Rail Housing
23	Machine Body	67	Cir-Clips for Shaft D=20	111	Circle Ring
24	Table Insert	68	Hex.Bolt M6 x 25	112	Supporting Plate
25	Rotating Block	69	Spring Washer 6	113	Dust Collection Tube
26	Tie-in B	70	Hex.Recessed Socket Screw M5 x 12	114	Rip Fence
27	Tie-in A	71	Hex.Bolt M8 x 25	115	Wing Nut
28	Saw Blade Guard	72	Hex.Bolt M8 x 16	116	Big Washer 6
29	Extension Table	73	Hex.Socket Cap Head Screw M8 x 20	117	Locking Screw
30	Adjusting Thread Rod Nut	74	Hex.nut M8	118	Neck Chain
31	Stop Collar	75	Cross Recessed Pan Head Screw M5 x 20	119	Dust Collection Tube Inside The Machine Body
32	Stop A	76	Hex.Nut M5	120	Cableland M14
33	Mounting Seat A	77	Washer 5	121	Cross Recessed Pan Head Screw M5 x 8
34	Angel Connection Knob	78	Ratchet Lever	122	Spring Pin 6
35	Locking Knob A	79	Bolt,blade guard	123	Key 5 x 20
36	Adjust Thread Rod	80	Cross Recessed Socket Screw M6 x 15	124	Worktable
37	Semi-Circle Key 3 x16	81	Hex.Socket Cap Head Screw M6 x 12	125	Scale Table Rotation
38	Front Panel	82	Hex.Socket Set Screw M8 x 8	126	Hex.Socket Cap Head Bolt M8 x 16
39	Mounting Seat B	83	Cross Recessed Pan Head Screw M4 x 6	128	Pointer
40	Height Adjusting Thread Rod	84	Washer 4	129	Stop Collar
41	Hand Wheel	85	Hex.Nut M4	130	Fence Plate
42	Right Panel	86	Spring Washer 4		
43	Left Panel	87	Cross Recessed Pan Head Screw M4 x 15		

EXPLODED DIAGRAMS/LISTS

106805 AW254TS Optional Sliding Table Kit Diagram B

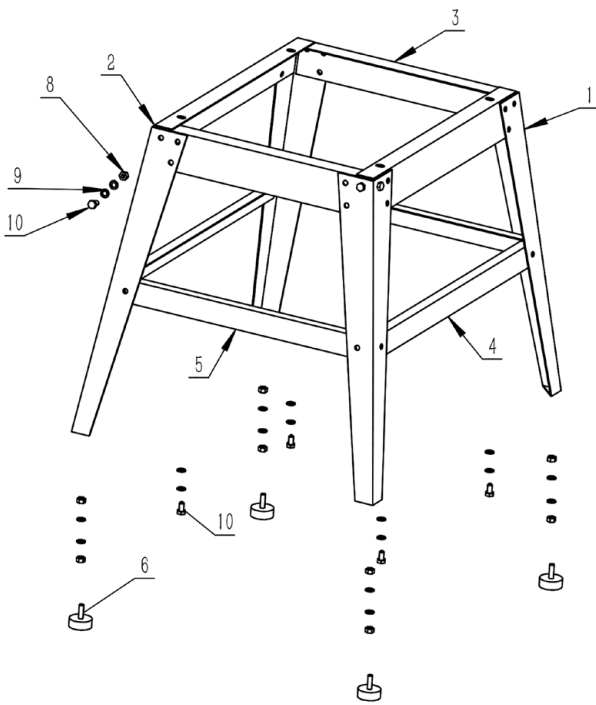


106805 AW254TS Optional Sliding Table Kit Diagram B

No.	Description
1	Mitre Gauge
2	Scale Mount
3	Wing Nut
4	Bolt Guide
5	Locating Bracket
6	Locating Plate
7	Scale
8	Stop Shaft
9	Knob-Lever
10	Spring Stop Shaft
11	Shaft Roller Wheel
12	Bush Roller Wheel
13	Roller Wheel
14	Hex.Bolt M8 x 20
15	Teeth Shape Washer 8mm
16	Hex.Nut M10
17	Washer 10mm
18	Hex.Socket Set Screw M6 x 6
19	Hex.Bolt M6 x 16
20	Hex.Bolt M6 x 55
21	Cross Recessed Pan Head Screw M5 x 30
22	Hex.Nut M6
23	Self-Locking Nut M6
24	Hex.Socket Cap Head Bolt M5 x 15
25	Hex.Nut M5
26	Cross Cut Fence
27	End Cap Cross Cut Fence
28	Taping Screw ST4.2 x 10
29	Step Bolt M6 x 45
30	Stud Hold Down
31	Arm Hold Down
32	Handle Hold Down
33	Eccentric Hold Down
34	Pin Hold Down
35	Cir-clips for Shaft 8mm
36	Washer 12mm
37	Cir-clips for Shaft 12mm
38	Stud Hold Down
39	Disc Hold Down
40	Spring Hold Down
41	Hex.Nut M12
42	Hex.Socket Cap Head Bolt M5 x 12
43	Washer 5mm
44	Star-Type Knob Hold Down
45	Ratchet Lever
46	Flip stop
47	Hex Socket Set Screw M5 x 5
48	Stud Hold Down
49	Flip Stop Base
50	Knurled knob
51	Screw Guide
52	Spring,flip stop
53	Ratchet Lever Flip Stop
54	Step Bolt M6 x 35
55	Spacer Ratchet Lever
56	End Cap Sliding Rail
57	Rubber Bush
58	Hex.Socket Cap Head Bolt M8 x 16
59	Washer 8mm
60	Hex.Nut M8
61	Carriage
62	Hex.Socket Cap Head Bolt M10 x 20
63	Hex.Flat End Set Screw M10 x 50
64	Washer 8mm
65	Spring Washer 8mm
66	Hex.Socket Set Screw M5 x 5
67	Big Washer 6mm
68	Mounting Bracket
69	Sliding Rail
70	Left Carriage Sliding Rail
71	Right Carriage Sliding Rail
72	Felt Pad
73	Dust Guard Plate
74	Press Plate Felt
75	Treaded Adjuster
76	Cross Recessed Pan Head Screw M4 x 8
77	Sliding Table

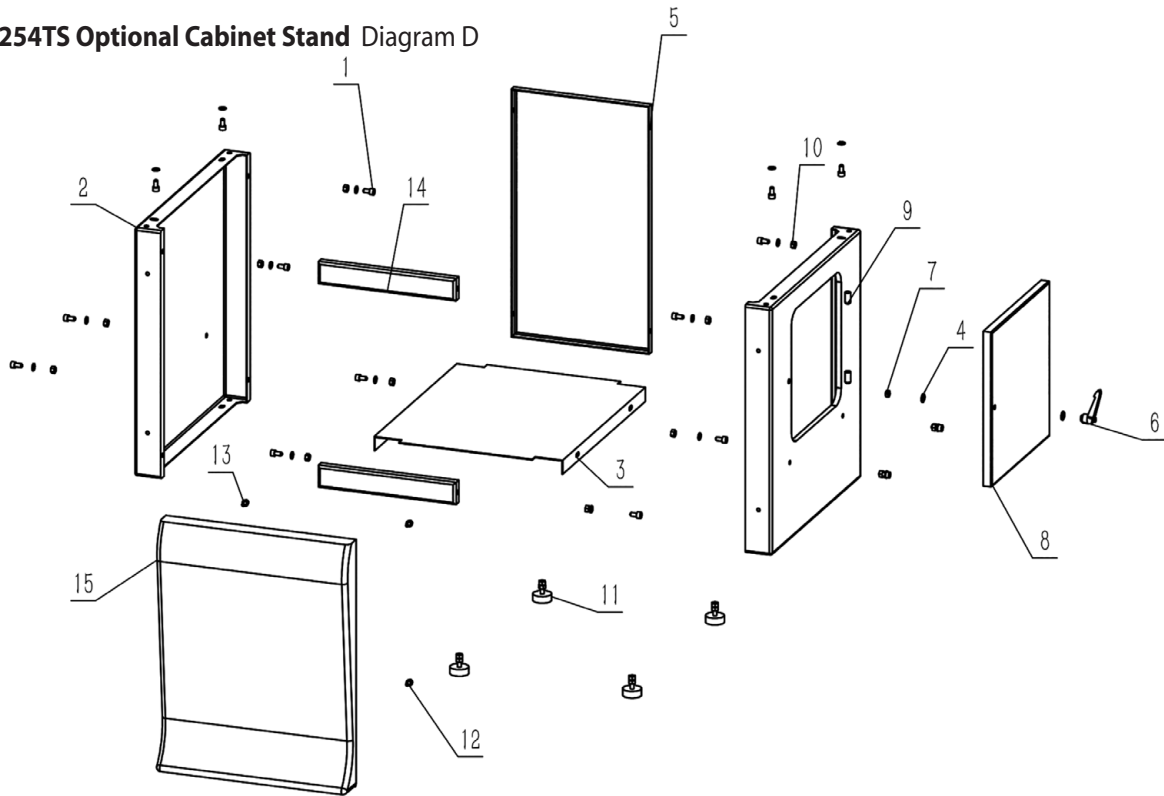
EXPLODED DIAGRAMS/LISTS

106806 AW254TS Optional Floor Stand Diagram C



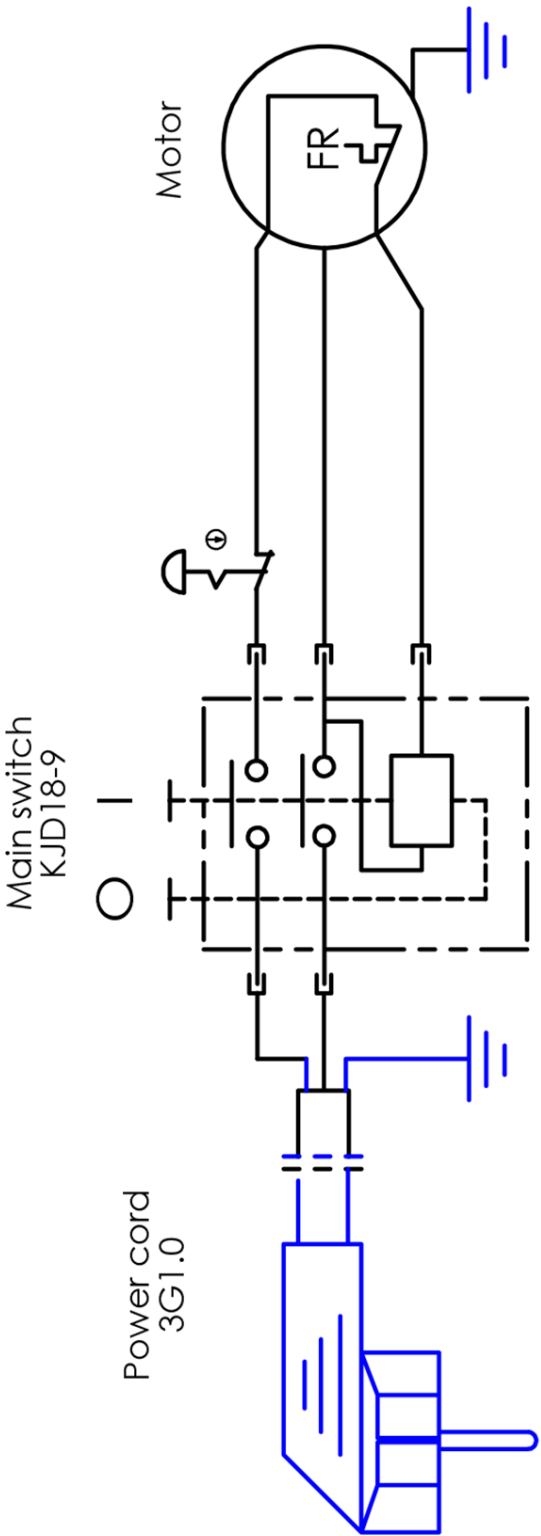
No.	Description
1	Stand Leg
2	Upper Long Bracket Stand Leg
3	Upper Short Bracket Stand Leg
4	Lower Long Bracket Stand Leg
5	Lower Short Bracket Stand Leg
6	Levelling Foot
8	Hex.Nut M8
9	Washer 8mm
10	Hex.Bolt M8 x 16

106806 AW254TS Optional Cabinet Stand Diagram D



No.	Description
1	Hex.Socket Cap Head Bolt M8 x 16
2	Left Panel Cabinet Stand
3	Internal Shelf
4	Washer 8
5	Rear Panel Cabinet Stand
6	Ratchet Lever
7	Self-Locking Nut M8

8	Access Door Cabinet Stand
9	Right Panel,Cabinet Stand
10	Hex.Nut M8
11	Levelling Foot
12	Hex.Socket Cap Head Bolt M6 x 12
13	Washer 6
14	Sidelong Support Front Panel
15	Front Panel Cabinet Stand



The Axminster guarantee

Buy with confidence from Axminster!

So sure are we of the quality, we cover all parts and labour free of charge for three years!



For more information visit axminstertools.com/3years



The packaging is suitable for recycling.
Please dispose of it in a responsible manner.



EU Countries Only

Do not dispose of electric tools together with household waste material.
By law they must be collected and recycled separately.



Axminster Tools, Axminster Devon EX13 5PH

axminstertools.com