



Code 109294

Original Instructions

Adjustable Hinge Jig

- Contains four adjustable hinge apertures.
- Can be used for hinges between 50mm(2") - 127mm(5") x 6.5mm - 35mm.
- Comes in two parts for easy storage.
- Based on a 2 metre door, the hinge positions are 6" from top; 20" from top; middle; and 9" from base.
- Overall Length of 1815mm (Approx 6')
- Has an end datum stop to control the 3mm gap between the top of the door and the frame.

Other Equipment required:-

- 12mm diameter straight cutter (666262).
- 16mm diameter guide bush.
- At least two bradawls (109377) to secure jig to door/frame.

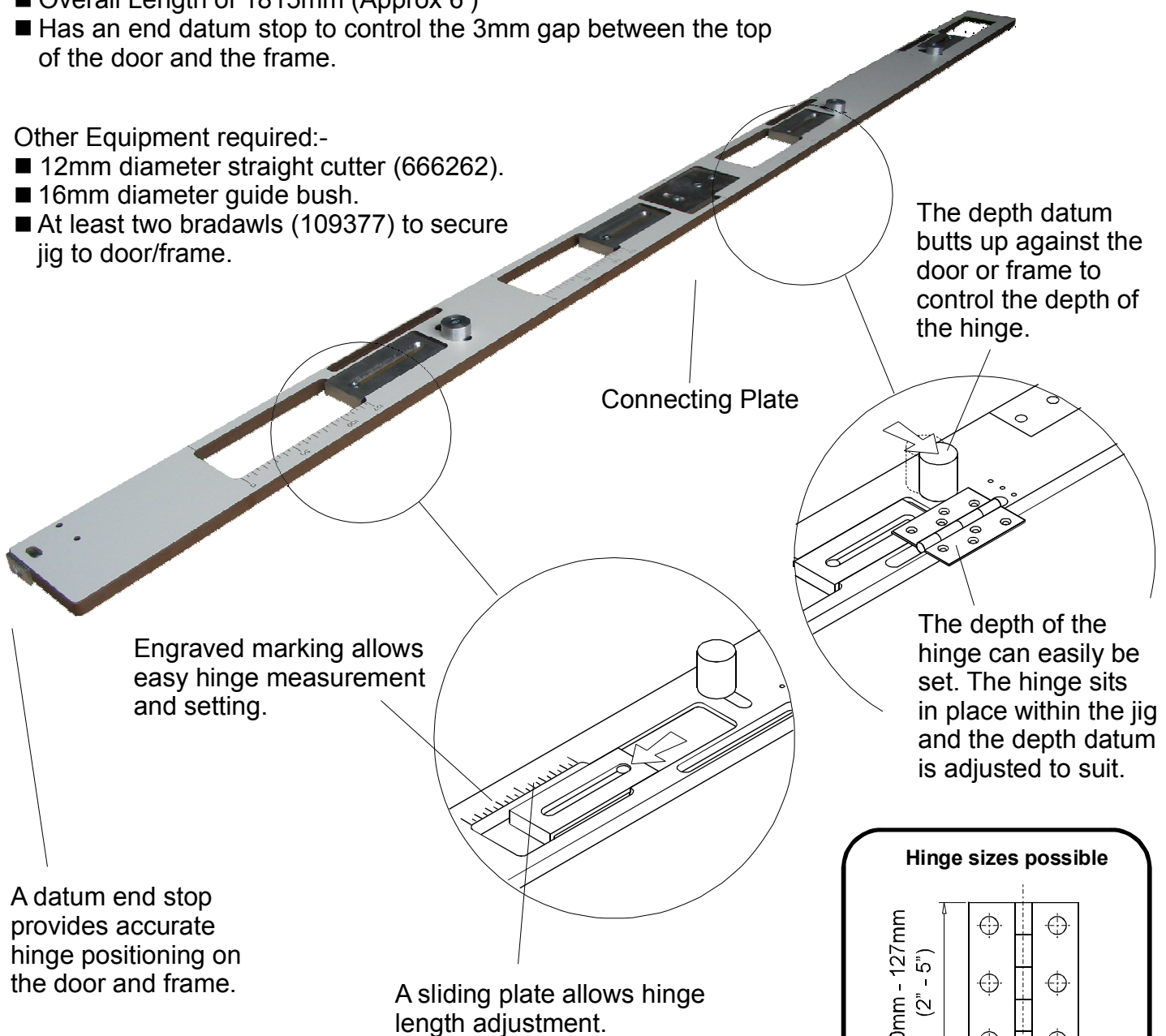

Hinge sizes possible

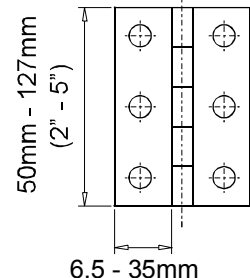

1. Assemble the Hinge Jig

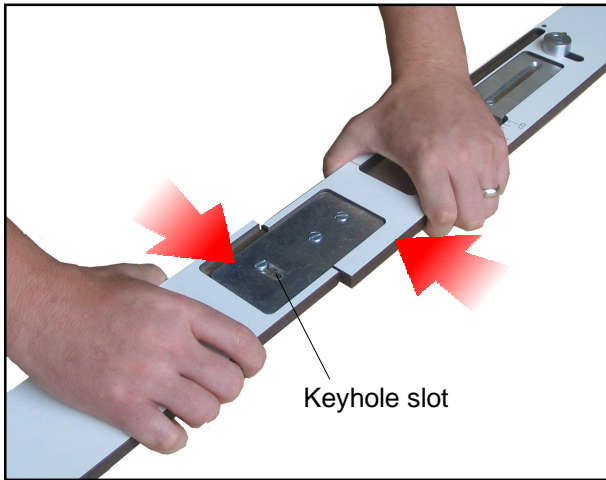

The two individual parts assemble together by a connecting plate. Use the keyhole slot to capture the head of the screw and pull both parts of the jig together in the direction shown in the diagram. Tighten the screw to secure the jig together.

Assemble the 3 pairs of aluminium bushes onto the jig if not done so already. There are 3 slots within the jig which they assemble to.

2. Set up the Hinge Length

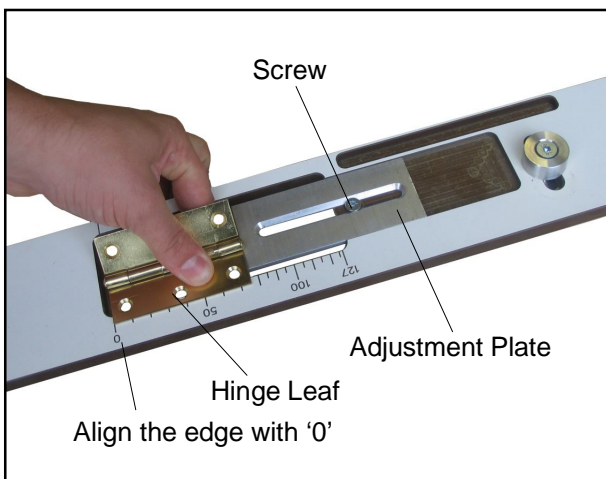

1. Adjust the length of the aperture using the engraved markings.
2. Loosen the screw so that the adjustment plate is free to slide.
3. Align the leaf of the hinge with '0' as shown in the photo left.
4. Slide the adjustment plate so that it touches the edge of the hinge. Tighten the screw to secure the adjustment plate in place.
5. Repeat this operation for the other 3 hinge apertures.

NOTE: If the length setup was done correctly then the length of the hinge aperture on the jig should be 4mm longer than that of the hinge itself. This is due to the guide bush and cutter offset - please see diagram below.

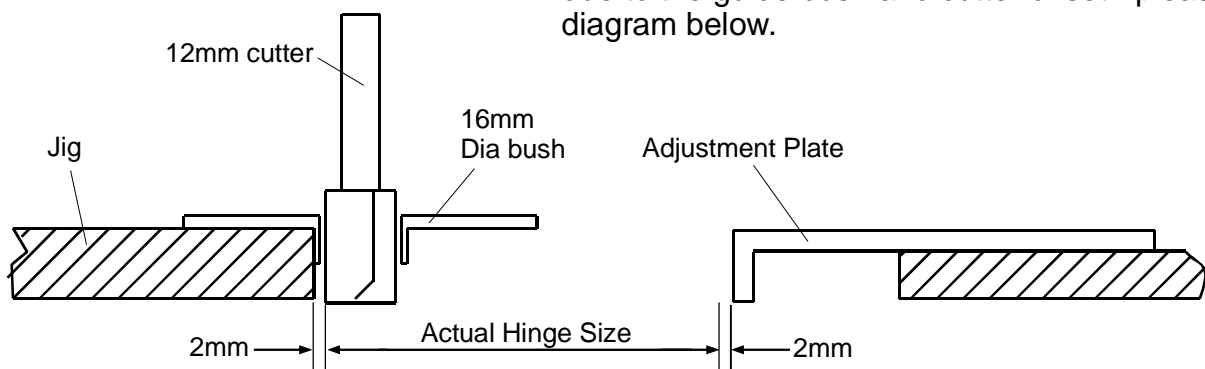

3. Set up the Hinge Depth

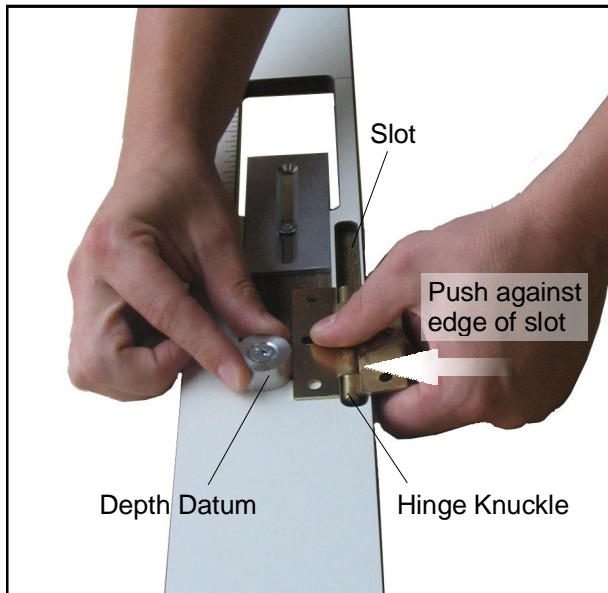

1. Loosen the depth datum.
2. Place the knuckle of the hinge in the slot as shown in the diagram, and push in the direction shown.
3. Move the depth datum so it butts up against the edge of the hinge.
4. Tighten the depth datum.
5. Repeat this sequence for all three depth datum bushes.

4. Rout Hinge Recesses in Door

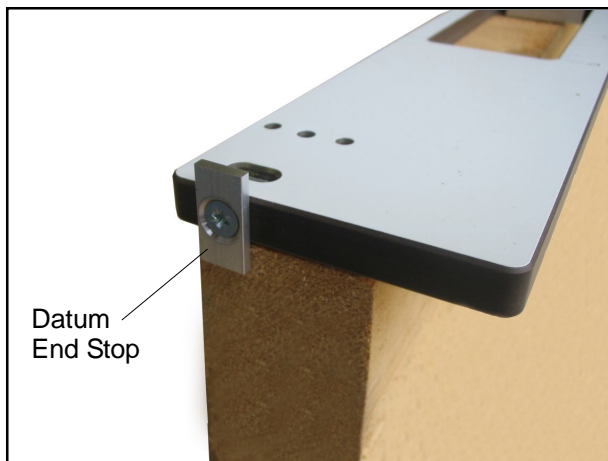

1. Lay the door down on its front edge and secure in position.
2. Loosen the screw securing the datum end stop and rotate 90 degrees - as shown in the photo left.
3. Tighten the screw to secure datum end stop.
4. The end stop hooks over the top of the door and positions the hinges in the correct place. Make sure the end stop is pushed against the top of the door.

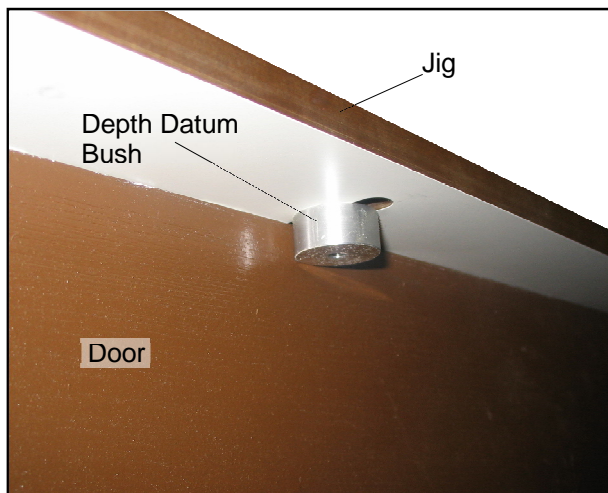

5. Make sure all three depth datum bushes are against the opening face of the door

Rout Hinge Recesses in Door cont...

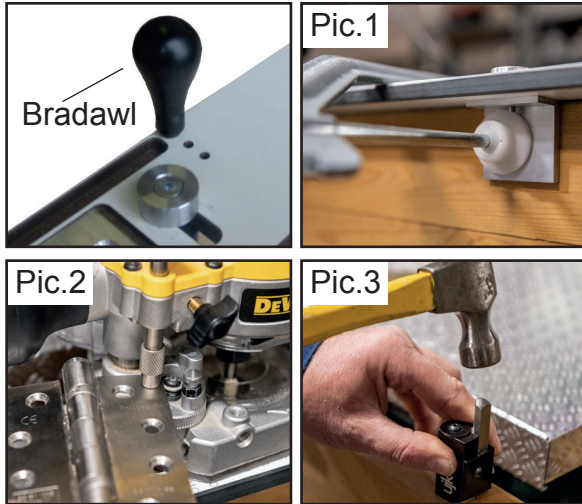

6. Secure the jig to the door with bradawls (not included) or use the clamp plates provided (Pic.1).
7. Set your router to the depth or slightly deeper than the hinge (Pic.2) - refer to your router manual for instructions on how to do this.
8. Continue to rout the three apertures into the door.
9. Remove the bradawls and the jig from the door.
10. Chisel the corners of the recess to fit the hinge. UJK Corner Chisel shown in picture (103864) (Pic.3).

5. Rout Hinge Recesses in Frame

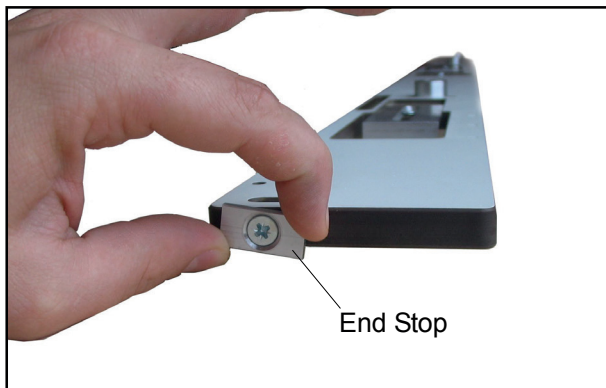

11. Loosen the screw which secures the end stop.
12. Turn the end stop back 90 degrees so that it is in line with the jig. Tighten to secure in place.
13. No further adjustments are needed for the frame.



14. The hinge recesses on the door have to be mirrored onto the frame. To do this, the side which was face up when routing the door, has to be faced against the frame.
15. Butt the jig up inside the frame as shown on the photo left. The end stop will shift the hinge recesses down by 3mm - this will give a 3mm gap between the top of the door and frame.
16. Make sure the depth datum bushes are against the open side of the frame
16. Locate the bradawls.
17. Continue to rout the recesses for the hinges.