







T50[®] STAPLE GUN

ENGLISH

| | |
|--------------------------------|---|
| SAFETY RULES..... |  P 2 |
| HOW TO LOAD STAPLES..... |  P 3 |
| ABOUT STAPLES..... |  P 4 |
| MAINTENANCE & ACCESSORIES..... |  P 5 |

Click Button
to go to page

ESPAÑOL

| | |
|---------------------------------|---|
| REGLAS SEGURIDAD..... |  P 6 |
| COMO CARGAR LAS GRAPAS..... |  P 7 |
| SOBRE LAS GRAPAS..... |  P 8 |
| MANTENIMIENTO Y ACCESORIOS..... |  P 9 |

Pulse el botón
para ir a la página

FRANÇAIS

| | |
|----------------------------------|--|
| CONSIGNES DE SÉCURITÉ..... |  P 10 |
| COMMENT CHARGER DES AGRAFES..... |  P 11 |
| AU SUJET DES AGRAFES..... |  P 12 |
| ENTRETIEN ET ACCESSOIRES..... |  P 13 |

Bouton-poussoir
pour aller à la page

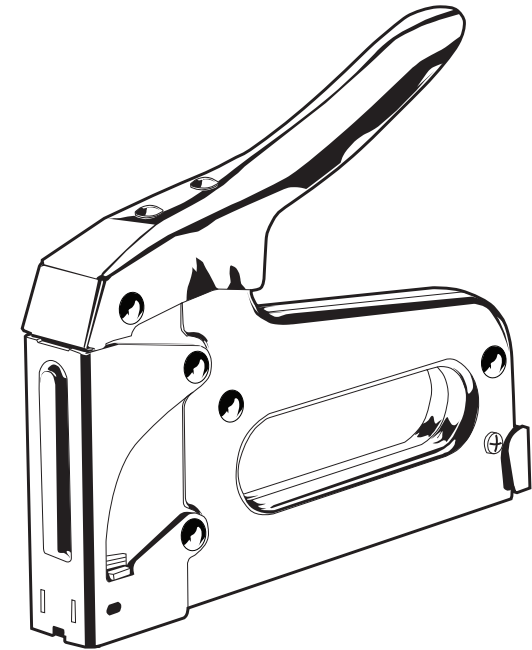



SAFETY RULES

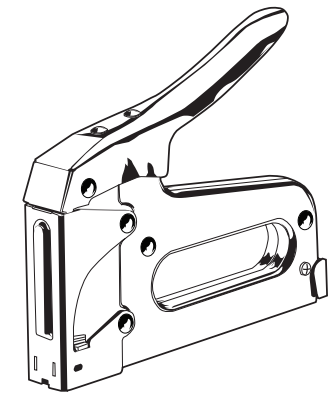

- Always be cautious of potential hazards such as electrical wiring, slippery footing, damp or wet conditions, etc.
- Make sure you know what you are fastening — look for hidden hazards.
- Keep work area clean. Cluttered areas and benches invite accidents.
- Keep children away. All visitors should be kept a safe distance from work area.
- Store idle tools. When not in use, tools should be stored in high or locked-up place out of reach of children.
- Use safety glasses.
- Do not overreach. Keep proper footing and balance at all times.
- Maintain tools with care. Follow instructions with care.
- For service, use only approved service centers.
- Use only original parts provided by the supplier.
- Stay alert — watch what you are doing. Use common sense.
- Do not staple into electrical wires. Be cautious of wires that may be hidden from view. Disconnect circuits.



BACK TO
INDEX





HOW TO LOAD STAPLES

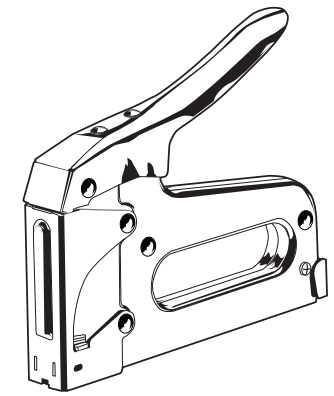

TO LOAD

1. Remove pusher rod from machine.
2. Insert strip of staples.
3. Replace pusher rod.

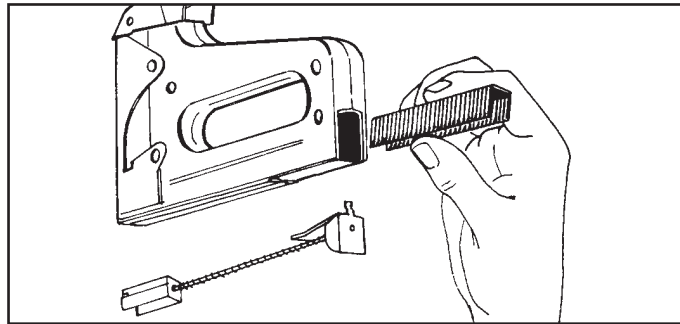

TO CLEAN STAPLE CHANNEL

1. Remove pusher rod A.
2. Remove screw and nut from hole B.
3. Pull down entire inside frame for complete cleaning.

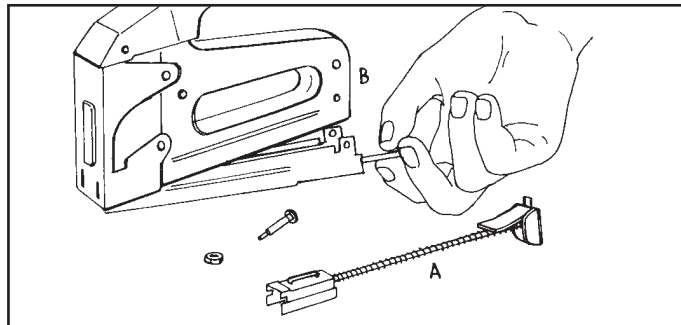

How to determine staple shortage for refill.

1. Press latch to release pusher rod.
2. Lightly push rod forward until it stops. Visible projected part of rod indicates amount of staples remaining in track.

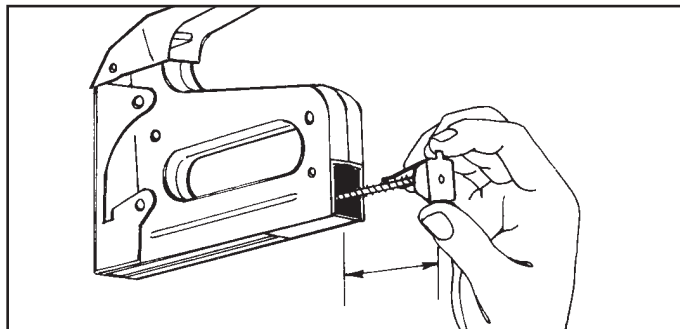

BACK TO
INDEX





ABOUT STAPLES

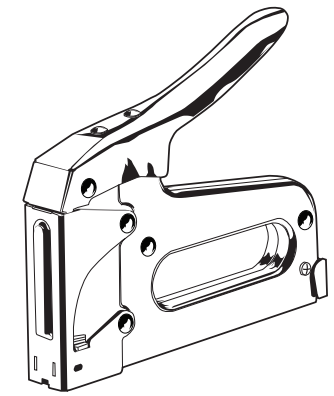

HOW TO DETERMINE PROPER STAPLE LEG SIZE

In choosing the proper staple leg length for a job there are two basic things to consider:

1. Thickness of material to be stapled.
2. Hardness of the wood.

As a general rule, in hardwood, approximately 3/16" to 1/4" penetration into the wood is sufficient...and for softwood – up to approximately 3/8" should be sufficient. However, if the staple used “stands away” from the work – this means that too long a leg length has been used. In that case we recommend the next shorter leg length for desired results.

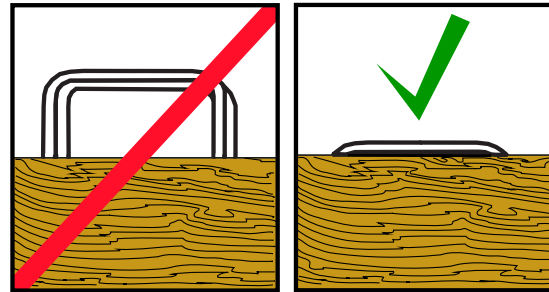

STAPLE PENETRATION

For best penetration with any gun tacker, raise the rear of the gun slightly off the work and bear down on the front end to prevent recoil when operating. The power spring on the T50® will drive well into all ordinary woods. A shorter staple leg will hold better in hard wood than a long leg in soft wood. Stronger springs can be supplied for special situations but they are not recommended as they shorten the life of the gun.

A WORD ABOUT ARROW® STAPLES

Only Arrow® knows the proper staple tolerances required for best performance of the T50® Staple Gun. Only Genuine Arrow® T50® Staples are made to these exact tolerances to insure top fastening performance. Accept no substitutes. Always insist on Genuine Arrow® Staples.

| | #504 | #505 | #506 | #508 | #50CT | #509 |
|-------------------------|-------------|--------------|--------------|--------------|----------------------------|---------------|
| T50® STAPLES | | | | | | |
| | 1/4" 6mm | 5/16" 8mm | 3/8" 10mm | 1/2" 12mm | 17/32" 13mm CEILTILE | 9/16" 14mm |

BACK TO INDEX





MAINTENANCE

Your T50® is virtually maintenance free. Keep tool clean and free of dust. Wipe clean with a dry cloth do not use harsh chemicals to clean your T50®.

PARTS KIT # PK50™ is available containing: Pusher Rod assembly , Clevis Pins & Rings, Screws & Nuts. In the unlikely event that you should need service contact:

Arrow Fastener Co., LLC
271 Mayhill Street, Saddle Brook, N.J. 07663
Tel. 201-843-6900

ACCESSORIES

Arrow accessories and genuine Arrow T50® Staples are available at retail outlets, hardware stores, lumberyards and wherever fine tools are sold.

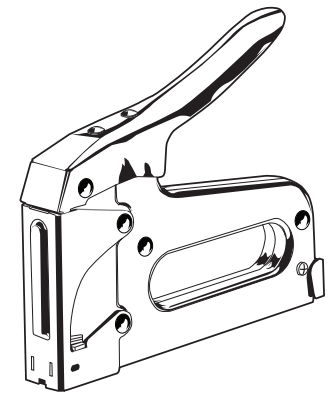

| | | | | |
|--|-------------------------------------|--|--|---|
| | T50®WA WIRE ATTACHMENT | | T50®SHA WINDOW SHADE ATTACHMENT | SBH1™ HANDS FREE BELT HOOK |
| | T50®SA SCREEN ATTACHMENT | | SL50™ STAPLE LIFTER | |

**BACK TO
INDEX**





REGLAS DE SEGURIDAD

- Siempre debe estar alerta a posibles riesgos tales como cables eléctricos, pisos resbalosos, condiciones húmedas o mojadas, etc.
- Asegúrese de saber lo que está fijando, esté pendiente de riesgos ocultos.
- Mantenga limpia el área de trabajo. Las áreas y bancas desordenadas propician accidentes.
- Mantenga alejados a los niños. Todo visitante debe permanecer a una distancia del área que no presente peligros.
- Almacene las herramientas que no están en uso. Cuando no se estén usando las herramientas se deben almacenar en un lugar elevado o cerrado con llave, fuera del alcance de los niños.
- Use gafas protectoras.
- No se estire demasiado para alcanzar algo. Siempre debe mantener el debido equilibrio.
- Dé mantenimiento a las herramientas meticulosamente. Obedezca las instrucciones con cuidado.
- Para obtener servicio, comuníquese solamente con los centros de servicio aprobados.
- Use solamente las piezas originales proporcionadas por el proveedor.
- Manténgase alerta, fíjese en lo que hace. Use el sentido común.
- No coloque la grapa en cables eléctricos. Este seguro que no haya cables que no se alcanzan a ver. Desconecte el circuito.

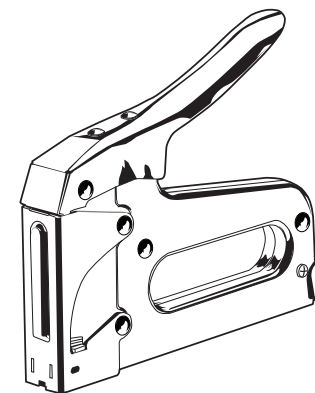

DE NUEVO
A ÍNDICE





CÓMO CARGAR GRAPAS

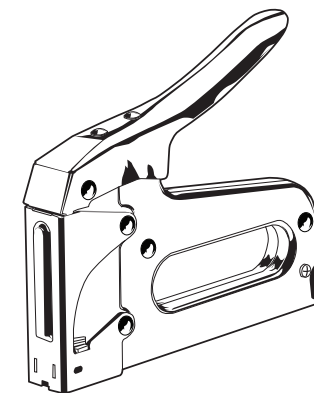

PARA CARGAR

1. Saque la varilla empujadora de la máquina.
2. Meta la franja de grapas.
3. Coloque la varilla de nuevo.

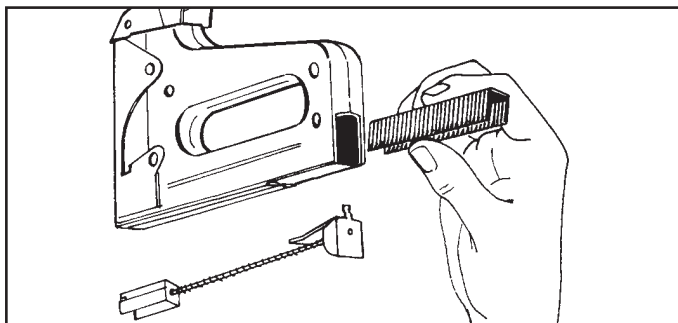

PARA LIMPIAR EL CANAL DE GRAPA

1. Saque la varilla A.
2. Quite la tuerca y el tornillo del agujero B.
3. Saque el canal de grapas para limpiarlo completamente.

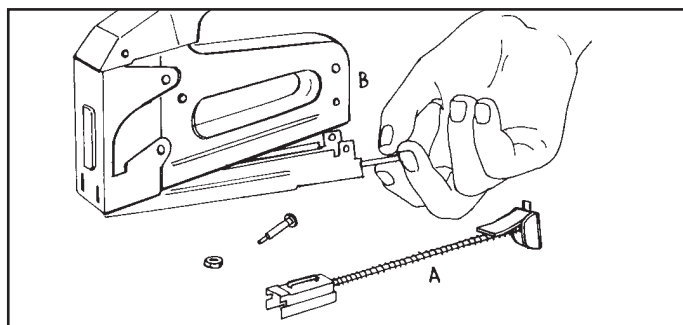

Como determinar la cantidad de grapas necesarias para relienar.

1. Oprima el pestillo para soltar la varia de alimentacion.
2. Empuje la varilla levemente hacia adelante hasta la parrada. Los componentes sobresalientes visibles de la varilla indican la cantidad de grapas que quedan en la carrilera.

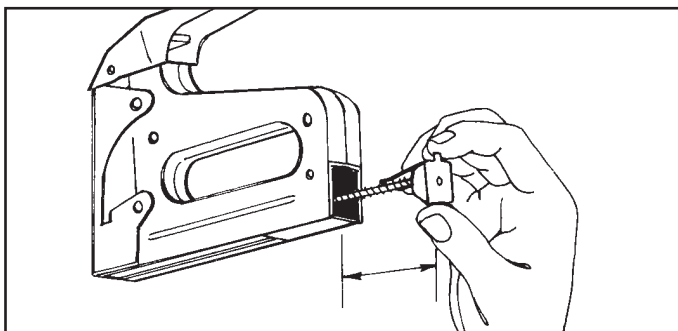

DE NUEVO
A ÍNDICE



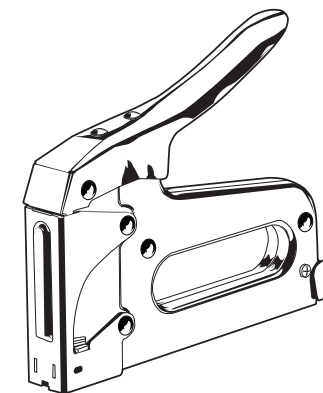

COMO DETERMINAR EL TAMAÑO DE PATA DE LA GRAPA PROPIO

Para escoger el tamaño de pata de la grapa apropiada para el trabajo – hay dos cosas básicas que considerar: 1. Espesor del material que se va a engrapar. 2. Dureza de la madera.

Como regla general, en maderas duras, una penetración en la madera de 3/16" a 1/4" es suficiente...y para maderas blandas hasta aproximadamente 3/8" debe ser suficiente. Sin embargo, si la grapa que se use sobresale del trabajo – quiere decir que se ha usado uno largo de pata demasiado grande. En ese caso recomendamos que se use el tamaño más corto que le sigue para tener el resultado deseado.

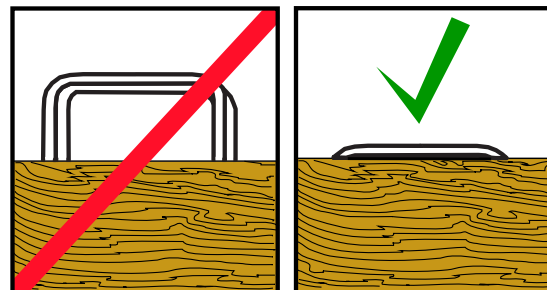

STAPLE PENETRATION

Para una mejor penetración, levante la parte trasera de la pistola cuando la este operando. La potencia de penetración de la T50®P es suficiente para el uso en todas las maderas regulares. Una pata de grapa más corta sostendrá mucho mejor en madera dura, que una pata larga en madera suave. Para situaciones especiales, se le puede aumentar la fuerza, pero esto, no es recomendable porque acorta la vida de la pistola.

A WORD ABOUT ARROW® STAPLES

Solamente Arrow® conoce las tolerancias de grapas y clavos apropiadas que se requieren para el mejor funcionamiento de la Grapadora T50®. Solamente Genuinas Grapas Arrow® T50® son hechas con las tolerancias exactas para asegurar el mejor funcionamiento de la engrapadora. No acepte sustitutos. Siempre insista en Genuinas Grapas y Clavos Arrow®.

| | #504 | #505 | #506 | #508 | #50CT | #509 |
|------------------------|-------------|--------------|--------------|--------------|----------------------------|---------------|
| T50® GRAPAS | | | | | | |
| | 1/4" 6mm | 5/16" 8mm | 3/8" 10mm | 1/2" 12mm | 17/32" 13mm CEILTILE | 9/16" 14mm |

DE NUEVO
A ÍNDICE



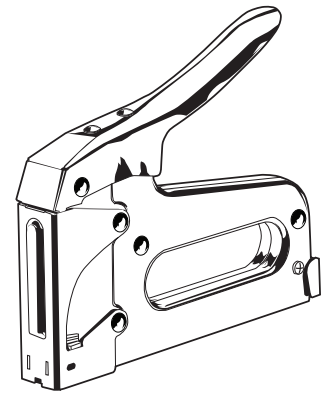

MAINTENANCE

Su T50® prácticamente no necesita mantenimiento. Mantenga su herramienta limpia y libre de polvo. No utilice químicos agresivos para limpiar su T50®, sólo use un paño seco.

Kit de piezas disponibles PK50T. Contenido: unidad del vástago del empujador, pasadores y anillos, tornillos y tuercas

En el improbable caso de que usted debe necesitar servicio, póngase en contacto con:

Arrow Fastener Co., LLC
271 Mayhill Street, Saddle Brook, N.J. 07663
Tel. 201-843-6900

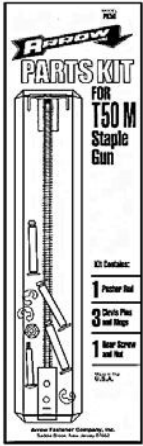

ACCESORIOS

Los accesorios Arrow® y las grapas Arrow® genuinas T50® se encuentran disponibles en tiendas de venta al menudeo, ferreterías, depósitos de madera y en cualquier sitio donde se vendan herramientas de calidad..

| | | | | |
|--|---|--|---|---|
| | T50®WA ACCESORIO PARA FIJAR ALAMBRES | | T50®SHA ACCESORIO PARA SOMBRA DE VENTANA | SBH1™ GANCHO DE CINTURÓN PARA MANOS LIBRES |
| | T50®SA ACCESORIO PARA TELA METALICA | | SL50™ LEVANTADOR DE GRAPAS | |

DE NUEVO
A ÍNDICE





INSTRUCTIONS DE SÉCURITÉ

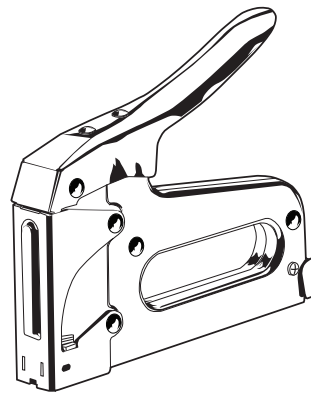

- Soyez toujours vigilant à cause de possibles sources de danger tels que les câblages électriques, les sols glissants, l'humidité, etc.
- Assurez-vous de bien connaître le produit que vous fixez cherchez les dangers cachés.
- Veillez à ce que l'aire de travail soit propre. Les locaux et plans de travail encombrés sont propices aux accidents.
- Veillez à ce que les enfants restent à l'écart. Tous les visiteurs doivent se tenir à une distance raisonnable des zones de travail.
- Rangez les outils qui ne sont pas en usage dans un endroit sûr, en hauteur ou sous clé, hors de la portée des enfants.
- Portez des lunettes de sécurité.
- N'essayez pas d'atteindre des points éloignés. Conservez votre équilibre en tout temps.
- Veillez à soigneusement entretenir votre outillage. Respectez scrupuleusement les instructions à cet effet.
- En cas de besoin faites appel exclusivement à un centre de dépannage agréé.
- Utilisez exclusivement des pièces d'origine disponibles chez votre fournisseur.
- Restez vigilant – donnez toute votre attention à votre travail. Faites preuve bon sens.
- Precaution: Avant d'agrafer, assurez-vous quel cable se trouve bien dans l'empreinte du bec de l'agrafeuse ceci afin d'éviter d'endommages les fils conducteurs.
Attention: Lors de la pose du cable, bien vérifier que celui-ci ne soit pas sous tension.



DE NOUVEAU
À L'INDEX





COMMENT CHARGER DES AGRAFES

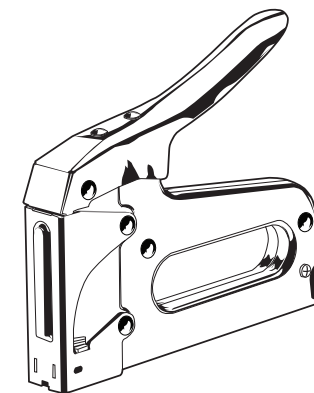

POUR CHARGER

1. Enlevez la tige de poussée de la machine.
2. Insérez un ruban de broches.
3. Retournez la tige à sa place.

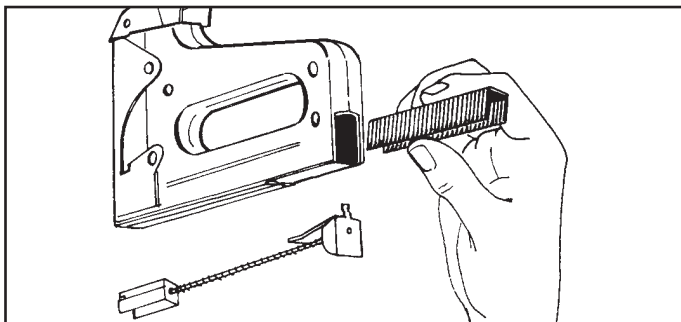

POUR NETTOYER LE CONDUIT DES BROCHES

1. Enlevez la tige A.
2. Enlevez la vis et l'écrou du trou B.
3. Tirez a bas toute l'armature intérieure pour un nettoyage complet.

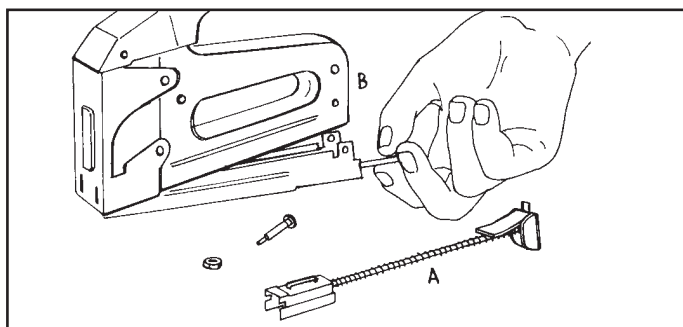

Comment déterminer la quantité de broches nécessaire pour remplissage.

1. Pressez le loquet pour relacher le poussoir.
2. Poussez la tige légèrement en avant, jusqu'à l'arrêt. Les composants saillants visibles de la tige indiquent la quantité d'agrafes qui restent dans a voie.

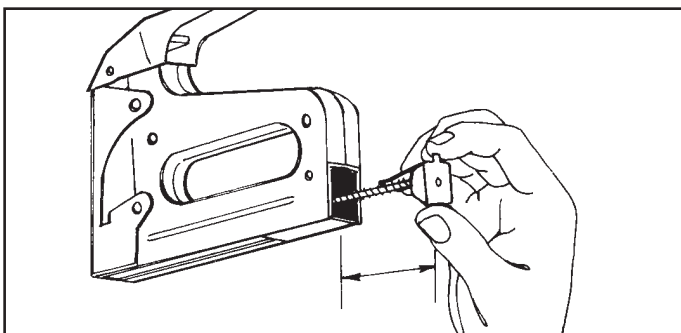

DE NOUVEAU
À L'INDEX





AU SUJET DES AGRAFES

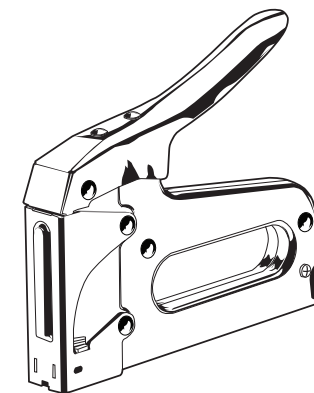

COMMENT CHOISIR L'AGRAFE APPROPRIÉE AU TRAVAIL À RÉALISER.

Le choix de l'agrafe dépend de deux éléments: 1. L'épaisseur du matériau à agraffer. 2. La résistance du bois.

En règle générale, avec les bois durs il faut utiliser des agrafes de 6mm à 8mm. Pour les bois tendres des agrafes 10mm suffisent. Cependant s'il y a un espace entre l'agrafe et le matériau cela signifie qu'une patte d'agrafe trop longue a été employée. Dans ce cas, nous préconisons l'emploi d'une agrafe de taille inférieure pour obtenir.

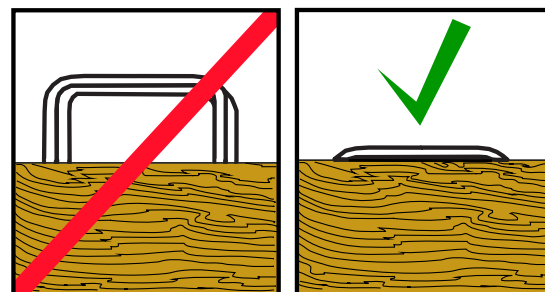

PENETRATION DES BROCHES

Afin d'obtenir la meilleure pénétration possible avec un pistolet brocheur quelconque, relevez légèrement l'arrière du pistolet audessus du material et apprêtez sur l'extrémité avant pour empêcher un recul du pistolet pendant le travail. Le ressort de poussée du T50®P entrera facilement dans toutes les especes de bois courantes. Dans le bois dur, une broche plus courte aura davantage de retenue qu'une broche plus longue dans du bois moins dur. Pour des conditions spéciales, il y a des ressorts plus forts, mais leur usage n'est pas à recommander car ils détériorent le pistolet.

UN MOT AU SUJET DES AGRAFES ET CLOUS ARROW®

Nous sommes les seuls à connaître les tolérances exactes pour les agrafes nécessaires pour obtenir les meilleurs résultats avec L'Agrafeuse Arrow® T50®. Seules les Véritables Agrafes Arrow® T50® sont fabriquées à ces tolérances exactes pour assurer les meilleurs résultats. N'acceptez aucune substitution. Demandez toujours réclamer les Véritables Agrafes Arrow®.

| | #504 | #505 | #506 | #508 | #50CT | #509 |
|-------------------------|-------------|--------------|--------------|--------------|----------------------------|---------------|
| T50® AGRAFES | | | | | | |
| | 1/4" 6mm | 5/16" 8mm | 3/8" 10mm | 1/2" 12mm | 17/32" 13mm CEILTILE | 9/16" 14mm |

DE NOUVEAU
À L'INDEX



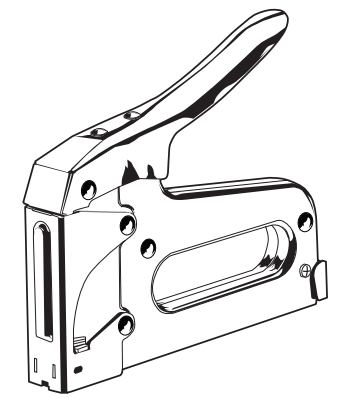

ENTRETIEN

Votre T50® ne nécessite pratiquement aucune maintenance. Conservez l'outil propre et dépoussiéré. Essuyez avec un chiffon sec et n'employez pas de produits chimiques abrasifs pour nettoyer votre T50®.

Kit de pièces disponibles # PK50™ - Contient: bouton poussoir assemblage de la tige, chapes épingle & anneaux, Vis & écrous

Dans le cas peu probable où vous avez besoin de service, contactez:

Arrow Fastener Co., LLC
271 Mayhill Street, Saddle Brook, N.J. 07663
Tel. 201-843-6900

ACCESSOIRES

Les accessoires Arrow® et les véritables agrafes T50® Arrow® sont disponibles dans les points de vente, les quincailleries, les sites de matériaux de construction et partout où l'on vend des outils de qualité.

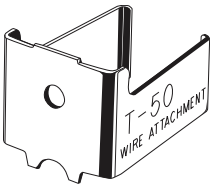
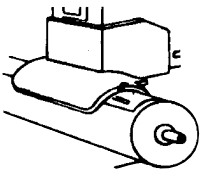
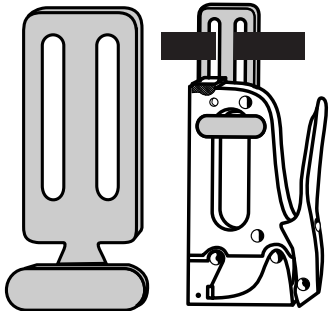
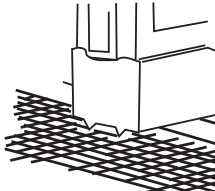
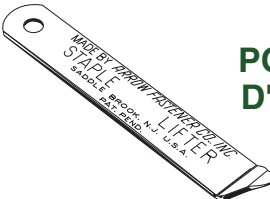
| | | |
|--|--|---|
|  <p>T50®WA ATTACHEMENT DE FIL</p> |  <p>T50®SHA ACCESSOIRE POUR OMBRE DE FENÊTRE</p> |  <p>SBH1™ CROCHET DE COURROIE POUR MAINS LIBRES</p> |
|  <p>T50®SA ACCESSOIRE POUR TOILE MÉTALLIQUE</p> |  <p>SL50™ POUSOIR D'AGRAFE</p> | |

DE NOUVEAU
À L'INDEX

