



Code 508619

Original Instructions

Adjustable Compact Locking Jig Instructions

- Contains four templates to control the width of the lock and face plate :-
Face plate widths are 25.4mm and 22.5mm; lock widths are 16mm and 19mm.
- The length of the lock jig aperture can be adjusted from 0 to 208mm.
- Quick and easy to set up.
- The jig has engraved markings to aid setting up.
- Does doors 33mm to 59mm.

Other Equipment required:-

- 12.7mm diameter straight cutter.
- 16mm diameter guide bush.
- At least two clamps to secure jig to door.
- Philips screwdriver.

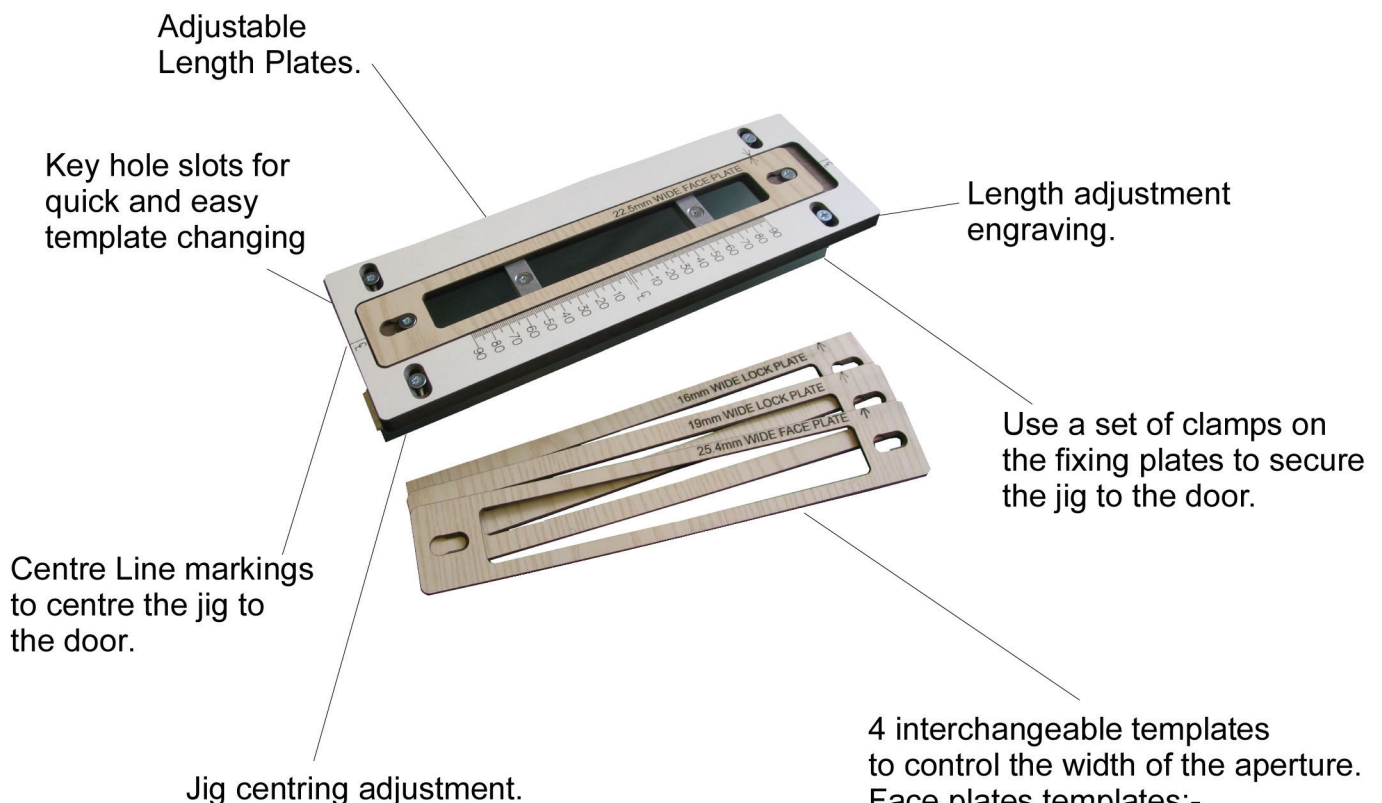

Adjustable Lock Jig

1. Positioning the Lock Jig

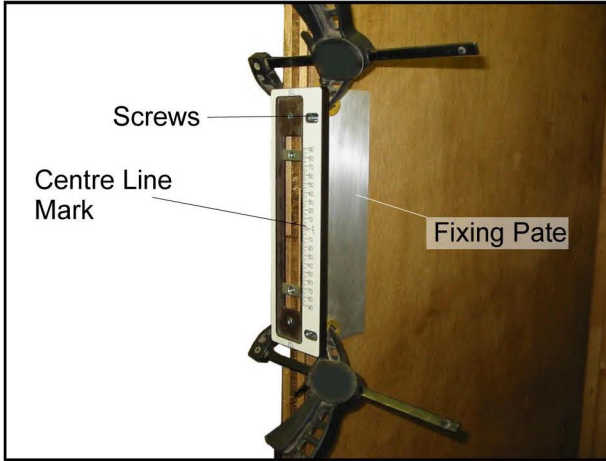

1. Mark where you want the centre of the lock to be on the height of the door. Use the engraved centre line to position the lock jig.
2. Clamp the fixing plates to the door.



3. Mark on the door above the jig the centre line. This centre line refers to the centre of the lock - see photo left.



4. Mark on the door below the jig to indicate the centre of the lock - see photo left.

Positioning the Lock Jig cont...

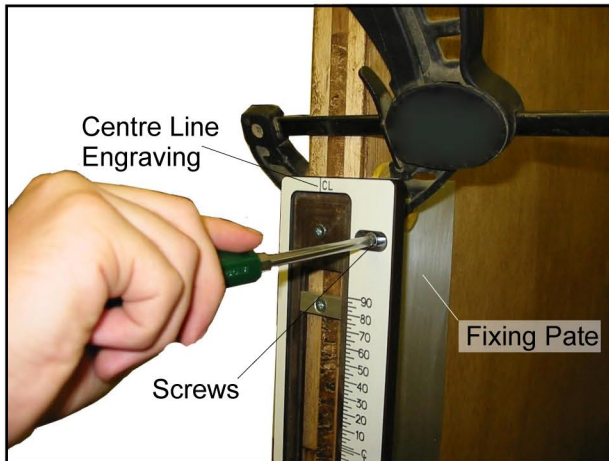

5. Loosen the two screws securing the lock jig to the fixing plates.
6. Align the centre line engraving on the jig (CL) to the centre line markings which were made on the door.
7. Once the jig is positioned correctly, tighten the two screws to secure the fixing plates to the jig.

2. Setting up the Lock Face Plate

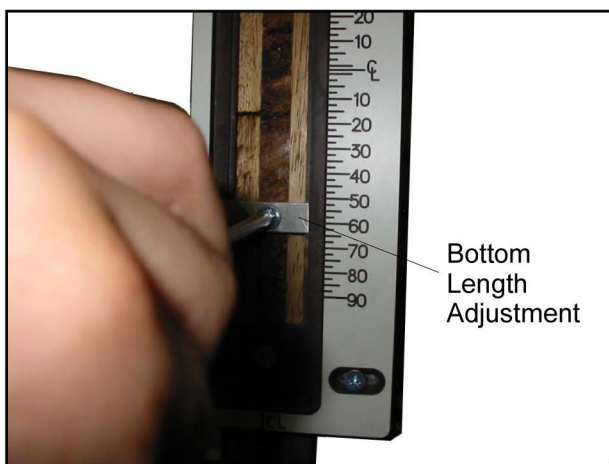

1. The length of the aperture for the face plate has to be set. Measure the face plate length.

For this exercise let's assume that the face plate is 100mm (4") long.

2. Loosen the bottom length adjustment screw, and slide it to 50 (half of 100mm). Note: The top edge of the bottom adjustment has to be in line with 50.

If your face plate was 150mm long then slide the bottom adjustment so that it is in line with 75.

3. Tighten the screw to secure the bottom adjustment in place.

4. Repeat this process for the top adjustment. For instance, if your face plate is 100mm long then move the top adjustment to 50.

5. Tighten the screw to secure the top adjustment in place.

6. The aperture length (the distance from the top adjustment to the bottom adjustment) should be 3.3mm longer than the actual face plate. This is due to the cutter and bush offset.

For instance, if your face plate is 100mm long then the distance between the adjustment plates should be 103.3mm. See the diagram on the next page for an explanation.

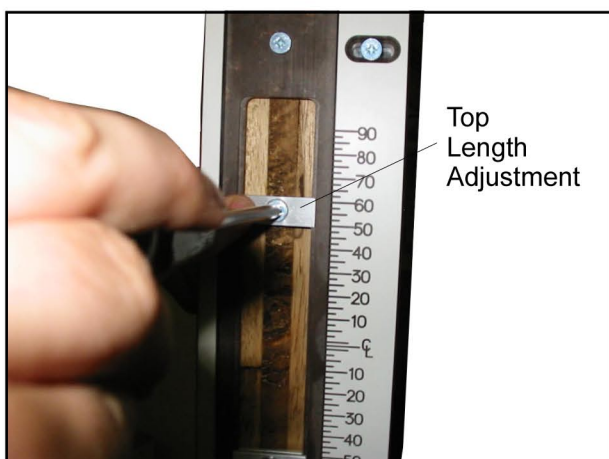

Setting up the Lock Face Plate cont...

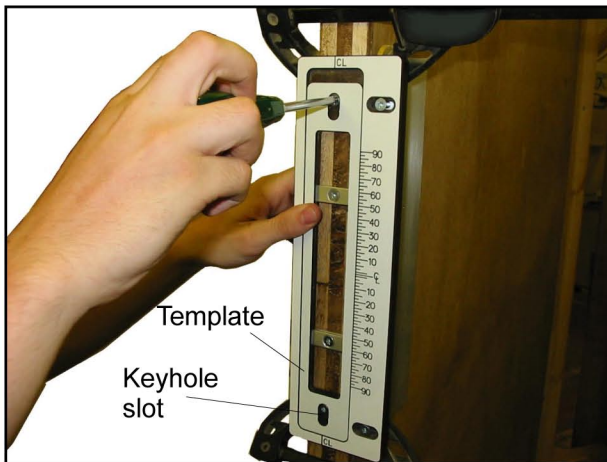
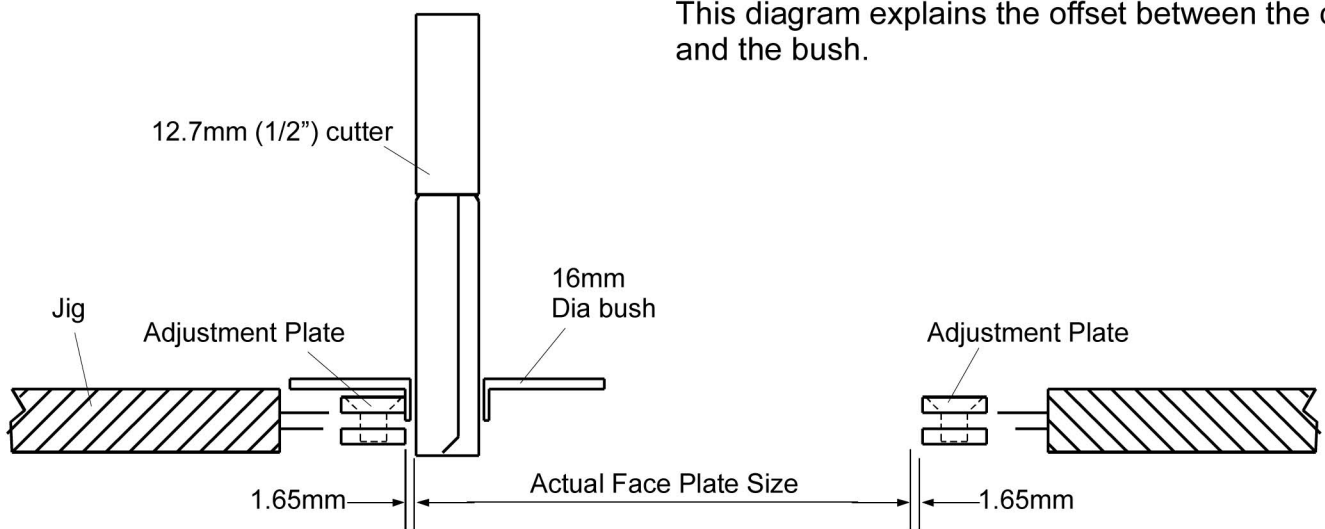

7. The width of the face plate/lock is governed by any of the four templates you use. Each has a letter or a number engraved on it which relates to the following widths:-

Face Plate Template "A" = 25.4mm
Face Plate Template "B" = 22.5mm

Lock Template "1" = 16mm
Lock Template "2" = 19mm

8. Decide upon the template and attach it to the jig using the keyhole slots. Make sure the arrows line up. Tighten the screws to secure the template.
9. The lock jig is now set. Set your router to cut the thickness of the face plate - refer to the router manual.
10. Continue to rout the face plate aperture.

3. Setting up the Lock Aperture

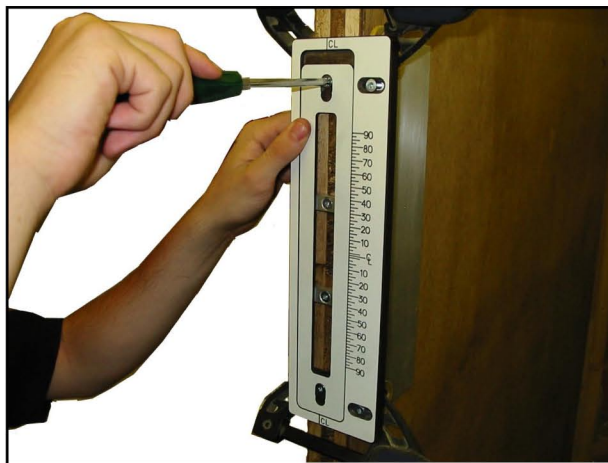
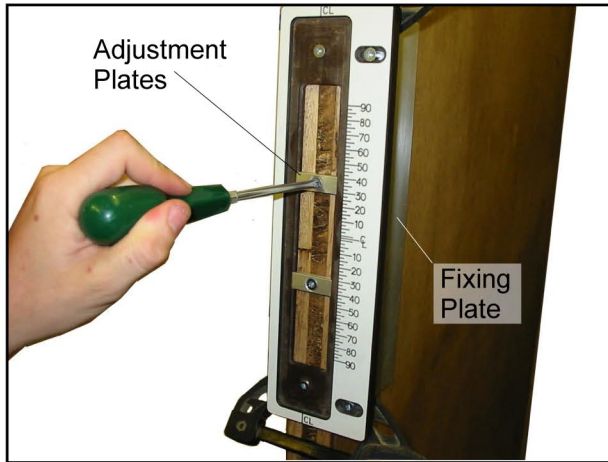

1. Do not release the clamps or the screws holding the fixing plates.
2. Loosen the screws which secure the template in place.
3. Remove the template.
4. Loosen the length adjustment screws and move the plates to suit the length of the lock. Example, if the lock is 80mm long then move the top plate to 40, and the bottom plate to 40.
5. The distance between the adjustments plates should be 3.3mm longer than the actual lock because of the cutter and bush offset (see previous page)
6. Tighten the screws to secure the adjustments plates.
7. Select the correct lock template. See previous page.
8. Insert the template into the jig and tighten the screws to secure in place.
9. Continue to rout the aperture for the lock. Do not exceed 5mm depth per pass.
10. Remove the lock jig and square off any corners which may obstruct the face plate and lock.