

## Dual Marking Gauge

05N70.01

- Ideal for laying out mortise and tenon joints
- Can be used as a single-cutter marking gauge
- Cuts a fine line for accurate chisel positioning

The Veritas® Dual Marking Gauge has two rods mounted eccentrically in the reference face. One rod has a non-rotating wheel cutter whose bevel faces the reference face (outside cutter) and the other has a non-rotating wheel cutter whose bevel faces away from it (inside cutter), allowing the gauge to be used in a wide range of applications. The hardened steel wheel cutters cut wood fibers rather than tear them, and produce fine cut-lines, ideal for chisel registration.

The most common use for this gauge would be as a mortise gauge for scribing both sides of a mortise. Unlike other mortise gauges, the cutters on the Veritas Dual Marking Gauge are used independently, scribing just one line at a time. As a result, this marking gauge can be used anywhere a project requires repeated marking of two dimensions.

The individual wheel cutters can be completely retracted into the reference face, and the gauge can function as a single-cutter marking gauge. For most traditional uses, the outside cutter (bevel facing the reference face) would be used; however, for thickening a workpiece, the inside cutter (bevel facing away from the reference face) would be used.

The eccentric configuration of the rods maximizes the size of the reference surface, while maintaining the overall size of the gauge. The short side can also be used if space is restricted. As an added advantage, the eccentric nature means this gauge is much less likely to roll off the work surface.

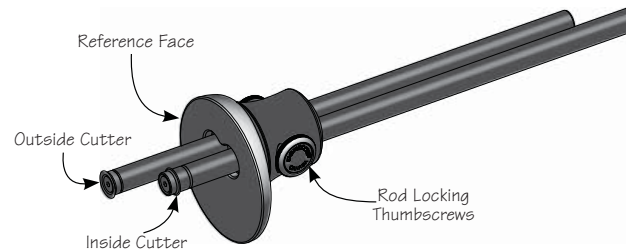

Figure 1: Veritas Dual Marking Gauge.

Patent Pending  
472 INS-463 Rev. B

## Setting the Gauge

The wheel cutters are oriented with opposing bevels, ensuring that you can always set the bevel on the waste side of a cut.

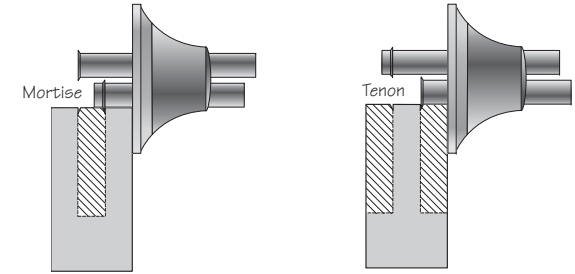

Figure 2: Setting the bevel on the waste side of the cut.

*Note: Each rod is set independently of the other.*

To set the gauge, loosen the appropriate thumbscrew and push or pull the rod through the body to the desired setting. An internal O-ring will keep light but constant friction on the rod, preventing it from accidentally slipping out. Tighten the thumbscrew to lock the setting.

The length of each rod is carefully controlled such that when the ends are aligned, so are the cutting edges of each cutter.

When marking a mortise, it is desirable to fit the mortise to the width of the chisel. Set the inside cutter to the front offset for the mortise, lock that rod in place and then set the outside cutter as shown in Figure 3.

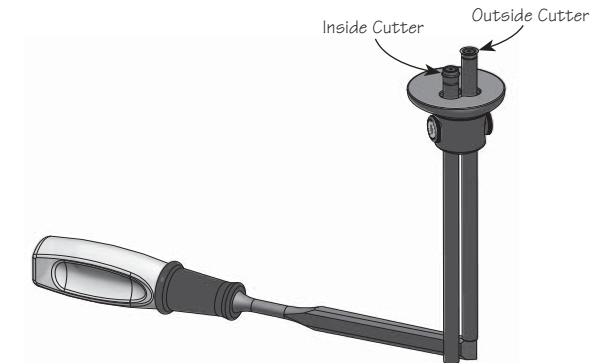
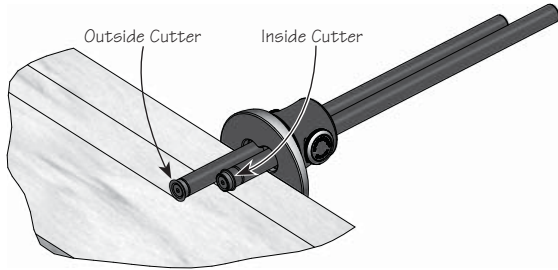

Figure 3: Setting cutters to match chisel thickness.

## Scribing a Line

As mentioned earlier in the instructions, the cutters are used independently, scribing just one line at a time. This not only produces a more defined line, but also provides better control. Position the gauge so that only one cutter is in contact with the workpiece.

To scribe a line with the gauge, slide it across or along a workpiece. To ensure the line is uniformly the same distance from the reference edge, be mindful to continually force the brass face plate against the workpiece. This is particularly important when using the inside cutter, as this cutter does not naturally draw the face into contact with the workpiece.

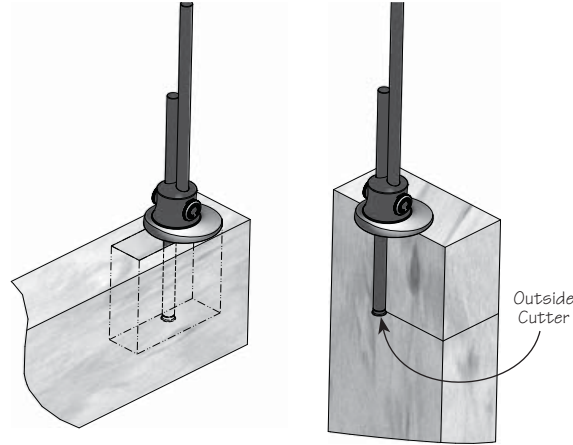

**Figure 4: Scribing one line at a time.**

When running a gauge along a workpiece, it is important to be aware that a knife-edge is prone to grain following in coarse woods (such as oak) if the grain lines approach the reference edge. To prevent this, move the gauge in the opposite direction.

## Transferring Dimensions

This marking gauge also excels at transferring dimensions. By setting the projection of the outside cutter to a known dimension, such as the depth of a mortise, you can easily transfer that dimension to mark the tenon's length.



**Figure 5: Transferring dimensions.**

## Care and Maintenance

Although the wheel cutters are hardened, over time they will need to be sharpened. Remove the securing screws, then the wheel cutters, and lap the face (non-bevelled side) of the cutter on a stone.

Note that the wheel cutters are not intended to rotate. Tighten the screws securely when re-installing the wheel cutters.

Also, as noted above, one rod is longer than the other so that when their ends are aligned, so are the cutting edges. The inside cutter should be installed on the longer rod (easily identified by the groove near the cutter end).

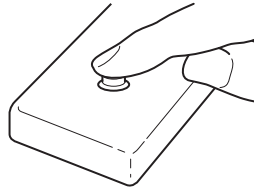

**Figure 6: Sharpening the wheel cutter.**

## Accessories

- 05N70.02** Replacement Outside Cutter
- 05N70.03** Replacement Inside Cutter
- 05N33.21** Standard Wheel Marking Gauge, Plain Rod
- 05N33.22** Standard Wheel Marking Gauge, Imperial Rod
- 05N33.23** Standard Wheel Marking Gauge, Metric Rod
- 05N35.10** Micro-Adjust Wheel Marking Gauge, Plain Rod
- 05N35.20** Micro-Adjust Wheel Marking Gauge, Imperial Rod
- 05N35.21** Micro-Adjust Wheel Marking Gauge, Metric Rod